

Received January 14, 2020, accepted January 28, 2020, date of publication January 30, 2020, date of current version February 6, 2020.

Digital Object Identifier 10.1109/ACCESS.2020.2970489

A Single-Phase Line-Interactive UPS System for Transformer-Coupled Loading Conditions

SYED SABIR HUSSAIN BUKHARI^{1,2}, (Member, IEEE), AND **JONG-SUK RO**^{1,2}, (Member, IEEE)

¹Department of Electrical Engineering, Sukkur IBA University, Sukkur 65200, Pakistan

²School of Electrical and Electronics Engineering, Chung-Ang University, Seoul 06974, South Korea

Corresponding author: Jong-Suk Ro (jongsukro@gmail.com)

This work was supported in part by the National Research Foundation of Korea funded by the Ministry of Education under Grant 2016R1D1A1B01008058, in part by the Human Resources Development of the Korea Institute of Energy Technology Evaluation and Planning (KETEP) grant funded by the Korea Government Ministry of Trade, Industry and Energy under Grant 20184030202070, and in part by the Korea Research Fellowship Program through the National Research Foundation (NRF) of Korea funded by the Ministry of Science and ICT under Grant 2019H1D3A1A01102988.

ABSTRACT A line-interactive uninterruptible power supply (UPS) system is one of the important installations implemented by industrial users to provide continuous power to sensitive industrial applications. Such loads often come with isolation transformers for voltage matching and protection purposes. Hence, a line-interactive UPS system experiences a serious problem of transient current when it operates under transformer-coupled loading conditions. The occurrence of this transient current can either impair the apparatus itself or turn on the overcurrent safety devices. In any situation, the interruption of electrical power for sensitive industrial loads is unavoidable. So as to keep the uninterrupted power and to eliminate transient current for industrial applications operating under transformer-coupled loading conditions, we propose a single-phase line-interactive UPS system based on a customary current-regulated inverter. The inverter of the proposed UPS system employs an improved current-regulating scheme implemented in a stationary frame of reference which regulates the load current and never let it to increase than a prescribed value as the transformer-coupled loads are turned on. Laboratory test results obtained under various operating and loading conditions of the single-phase line-interactive UPS system verify the operation of the proposed system.

INDEX TERMS Line-interactive, flexible loading conditions, transient current, transformer-coupled loads.

I. INTRODUCTION

During the past few years, problems associated with the power quality has gained much attention. The damaging of equipment and termination of manufacturing processes are affected diversely due to the outages and unanticipated voltage sags [1]–[9]. So as to counter the problems associated with the effects of sags and outages, a UPS system is generally mounted to deliver continuous power to the sensitive industrial loads [10]–[12]. Moreover, the UPS system is categorized into three types on the basis of its operation and configuration. These three types comprise of online, offline, and line-interactive [13]–[18]. However, among these types, the line-interactive UPS system has always been the preferred choice for industrial consumers owing to its high efficiency and high power-compensating capabilities as compared to offline and online UPS topologies [1].

The associate editor coordinating the review of this manuscript and approving it for publication was Sze Sing Lee¹.

In the case of the line-interactive UPS system, it is further subdivided into two diverse topologies. In the first topology, the inductors are attached in series with the critical load and utility as presented in Fig. 1 (a) [19]–[21]. However, in another topology, a bilateral converter would be attached in parallel with the utility and operates differently during the regular and irregular power obligations. In regular power conditions, it operates as a battery charger. However, as the irregularities occur, it functions as an inverter to supply backup power to the load. The main achievement of this topology is the suppression of the input current harmonics. However, there will be a very small amount of reactive power compensation. Due to the incorporation of a triport transformer amongst the load and utility for isolation, the size of the system increases [22]–[25].

A line-interactive UPS topology based on a series-parallel compensated system is also termed as the “delta-conversion” UPS system. It improves performance and has several advantages compared to the conventional UPS systems [26]–[32].

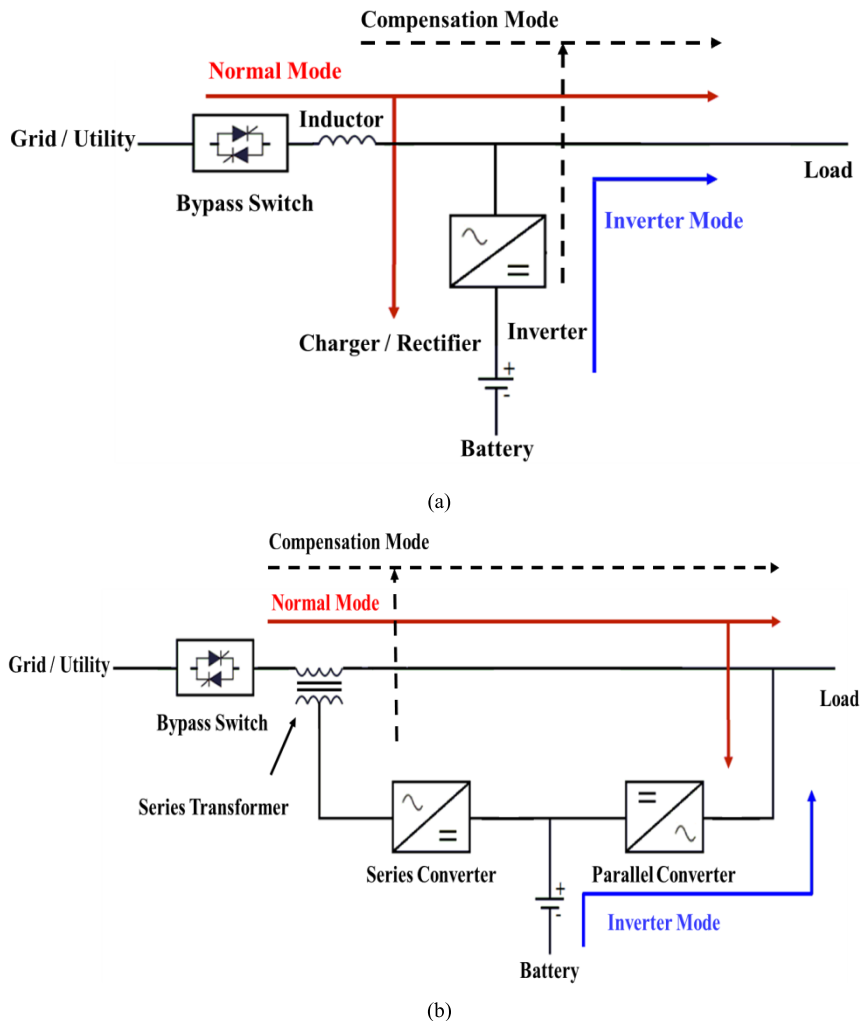

FIGURE 1. One-line diagram of a conventional line-interactive UPS system based on (a) single converter, and (b) dual converter.

Moreover, it comprises of two converters, one is in parallel to the load, the other one is tied in series with the utility through a series transformer, as depicted in Fig. 1 (b). During the normal conditions, the power is directly given to the load from the utility. However, the parallel converter offers the operation of battery charging, power factor improvement, and control of input-current harmonics. Contrarily, the power converter connected in series operates as a voltage regulator to mitigate the problems of voltage sag and swell. However, during uncertainties, the load is detached from the utility through the bypass switch and is powered by the battery through the parallel converter. Hence, this UPS system offers higher efficiency when compared to conventional topologies [33], [34].

In most of the industrial applications, a line-interactive UPS system is used to power multiple loads at a time. These loads comprise of load transformers for isolation and voltage matching purposes, and the UPS system is employed to energize the loads through their corresponding load transformers. Owing to the production processes and forecasts, these loads may turn on and off periodically, and the transformers

installed before them are energized and de-energized simultaneously. Fig. 2 portrays the single-phase line-interactive UPS system energizing the multiple loads.

A significant magnitude of transient current will appear on the output of the line-interactive UPS system once the transformer is energized. There are various factors affecting the enormity of this current such as the operational circumstances of the transformer and its magnetic properties. The production of inrush current for the line-interactive UPS system causes a substantial voltage drop and consequently triggers the overcurrent protection devices of the system. This causes a suspension of the applications and processes. On the other side, transient inrush current can, in a time span, cause the equipment to malfunction. In general, an industrial consumer might experience considerable economic damage during any of these cases.

In recent years, a lot of solutions have been suggested to mitigate the transformer inrush current. These techniques may also be adopted for a single-phase line-interactive UPS system when it is energizing the multiple

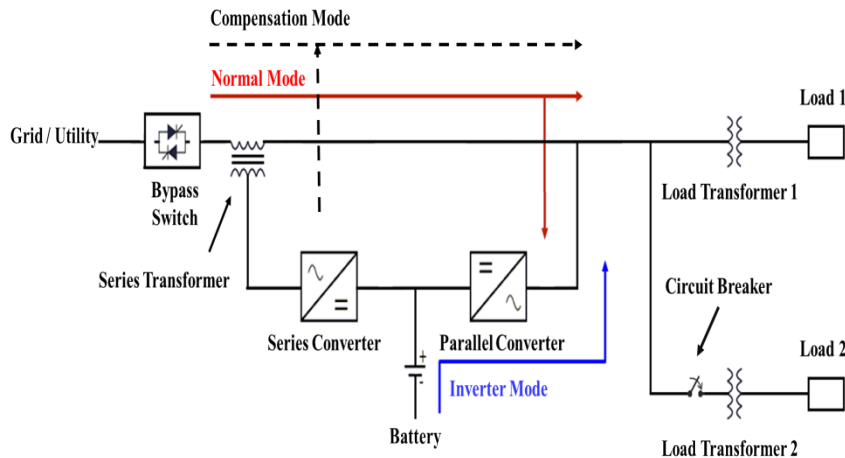

FIGURE 2. One-line diagram of a conventional double-converter-based line-interactive UPS system that powers multiple loads.

transformer-coupled loads. Installation of series resistors and their operation during powering the load transformer is considered the appropriate solution for the capacitive type of inrush current. Under such a condition, a limited current pass from the resistor and charges the capacitor until the voltage across it attains a point that allows the resistor to be shunted out of the circuit by means of a switch. This operation is completed as soon as the difference in the potentials between the capacitor and the peak source voltage is adequately close by. Hence, the current into the capacitor remains within the limits.

For inductive inrush currents, the effects are significantly changed. The series resistor will possibly reduce the size of the inrush current. However, there will be some irregularities in the waveform. As soon as the resistor is shunted by means of a switch, as in the case of the capacitive inrush current, the circumstances that would have occurred without the resistor will now exist, albeit at a lower scale. The common issues with this solution are the cost and size. Large resistors, control circuits, and electromechanical switches are required. Hence, this situation is avoided for single-phase line-interactive UPS systems [35], [36].

An alternative solution especially for the inductive type of inrush current is to mount an additional inductor in series with the primary winding of the transformer. This series inductor offers supplementary impedance and limits the current at the primary of the load transformer. Although this technique solves the phenomenon of inrush transient current for inductive inrush currents, it may not help in obtaining waveform asymmetry.

Another solution is to design a transformer having the flux level less than twice the level of the core saturation under steady-state conditions. Hence, when the inverter injects the load voltage, the load transformer will not saturate, and the chances of inrush current are eradicated. However, this method increases the size and cost of the system.

To reduce the amount of inrush current related with single-phase line-interactive UPS systems, a method that involves

the ramping-up of the inverter voltage when the inrush current is detected or turn the inverter on at the right phase instant can be used. In this technique, control and power circuits are used to inject the inverter's voltage at a 90° angle. Although this technique reduces the magnitude of the transient current. However, its implementation becomes complex or sometimes impractical for industrial applications.

Instead, there is a complex control strategy that includes a flux offset compensation process that works in a synchronous frame to control the flux of the load transformer. However, the inrush current phenomenon is not solved and remains at a reduced magnitude [37].

This paper proposes that the occurrence of inrush current associated with the transformer-coupled loads for a single-phase line-interactive UPS system can be eliminated by using a current-controlled inverter. Although any of the sophisticated high bandwidth control schemes can be used for this purpose. However, the inverter of the suggested UPS system utilizes a current control scheme executed in a stationary frame of reference. The employed control scheme is based on recently developed control schemes which were initially intended for variable frequency motor control [38]–[40]. Nonetheless, they were also fit to precisely control the AC currents with any balanced load, with and without an associated EMF (i.e., motor load). The key motives behind employing this current control scheme are: (1) it is simple and easy to implement when compared to the $d-q$ rotating frame or $P +$ resonant control based schemes, and (2) its performance can substantially be enhanced and the gain limitations led by the PI controller while dealing with AC signals can expressively be abridged by means of a simple feedforward compensation method as presented in [40]. This control scheme allows the proposed UPS system to vary its output current based on the rating of the switching load without any inrush current. As the enormity of the inrush current varies with the switching circumstances of the load transformer [41]. Hence, the performance of the proposed single-phase line-interactive UPS system is confirmed by experimental results obtained under different operating and switching conditions.

II. INRUSH CURRENT

To investigate the quantifiable behavior of the transient current that occurs during the energization of the load transformer, it is assumed that the voltage applied at the moment, the transformer is first connected to the power supply through the circuit breaker is:

$$v(t) = V_m \sin(\omega t + \theta) \tag{1}$$

The maximum flux value reached during the first half period of the applied voltage depends on its phase. If the initial voltage is

$$v(t) = V_m \sin(\omega t + 90^\circ) = V_m \cos \omega t \tag{2}$$

and if the initial value of the flux during the energizing of the load transformer is zero, then the maximum flux during the first half-cycle will be equal to the maximum flux in the steady-state. The value of this maximum flux can be found by using the equation:

$$\phi_{\max} = \frac{V_m}{\omega N_p} \tag{3}$$

However, in case of the following applied voltage:

$$v(t) = V_m \sin \omega t \tag{4}$$

the maximum flux during the first half-cycle is given by

$$\begin{aligned} \phi(t) &= \frac{1}{N_p} \int_0^t V_m \sin(\omega t) dt \\ \phi_{\max} &= \frac{2V_m}{\omega N_p} \end{aligned} \tag{5}$$

where N_p is the primary number of turns of the load transformer.

Equation (5) shows that the maximum flux will be twice as high as the normal steady-state flux. This maximum flux in the core of the load transformer results in an enormous magnetizing current (I_m) to produce the required magnetomotive force (MMF). The magnitude of the magnetizing current can be calculated using the following equation:

$$I_m = \frac{MMF}{N_p} \tag{6}$$

Typical behavior of the MMF corresponding to a given flux of a transformer and its magnetizing current is illustrated in Fig. 3 (a) and (b), respectively.

The magnitude of this current can be 2-6 times the rated current and depends on several factors, such as the magnetic characteristics of the load transformer and the operating conditions. This current appears at the output of the UPS system once the transformer-coupled load is turned on.

The maximum magnitude of the inrush transients of the load transformer is usually observed when the phase angle of the applied voltage is 0° . However, the same magnitude can be reduced to a significant level when the phase angle of the applied voltage is 90° [41].

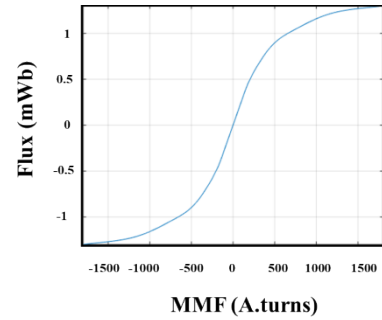

(a)

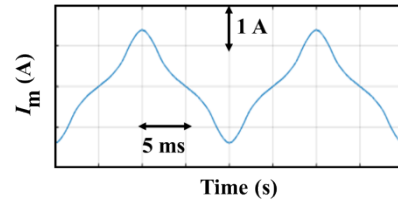

(b)

FIGURE 3. Typical transformer (a) MMF corresponding to given flux, and (b) magnetizing current.

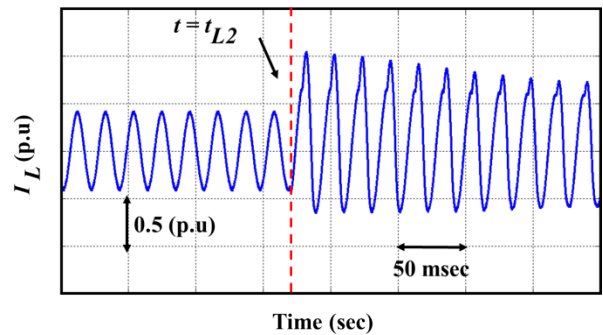

FIGURE 4. The load current of the conventional single-phase line-interactive UPS system for transformer-coupled loading conditions.

III. OPERATION AND PERFORMANCE

The principle of operation of existing and proposed single-phase line-interactive UPS systems under transformer-coupled loading conditions is discussed as follows:

A. CONVENTIONAL SINGLE-PHASE LINE-INTERACTIVE UPS SYSTEM OPERATING UNDER TRANSFORMER-COUPLED LOADING CONDITIONS

Fig. 2 shows a conventional single-phase line-interactive UPS system powering multiple loads. In order to investigate the operation of this UPS system, we assume that load transformer 1 along with its respective load is online. However, load transformer 2 is offline. At a certain time, when $t = t_{L2}$, load transformer 2 is connected to the system using the provided circuit breaker. As load transformer 2 is connected to the UPS system, the output current I_L increases from 0.42 (p.u) and attains a peak of 1.04 (p.u), which

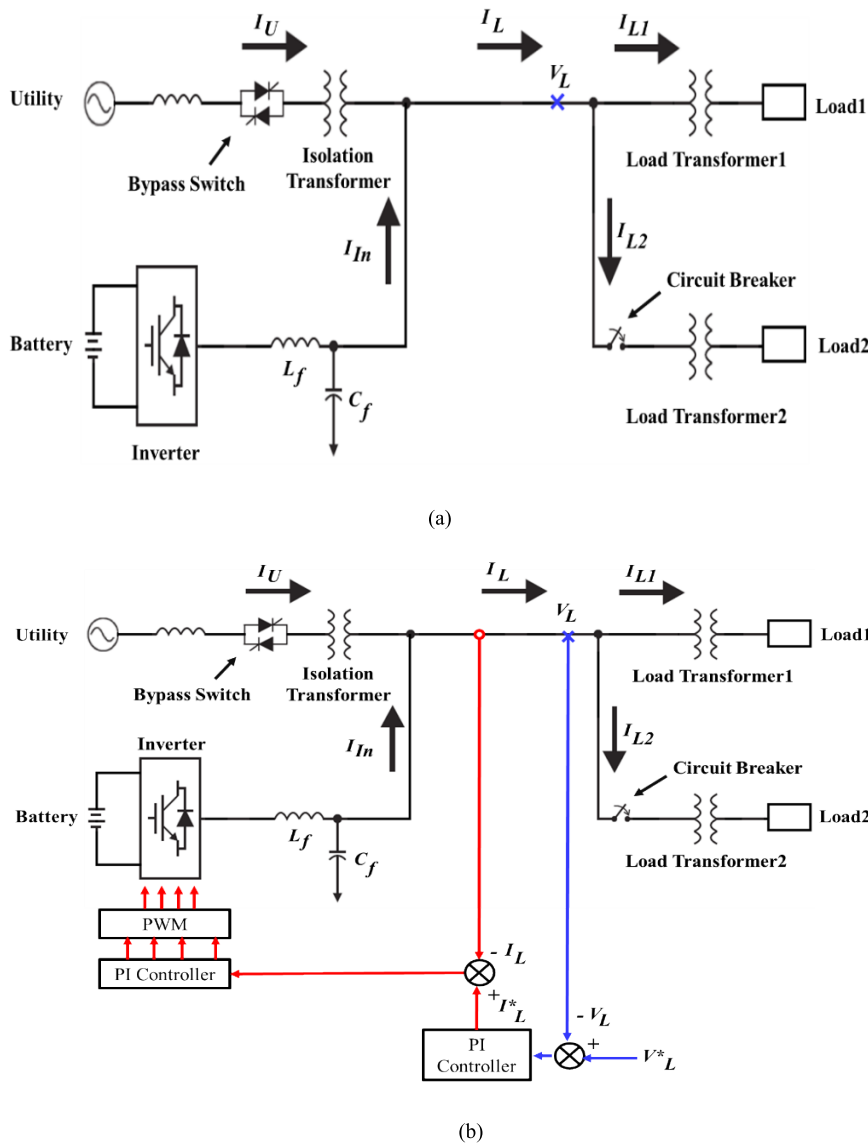

FIGURE 5. (a) Simplified and (b) complete diagrams of the proposed single-phase line-interactive UPS system operating under transformer-coupled loading conditions.

is 0.47 (p.u) higher than the rated load current. The rated load current of the UPS system after the connection of load transformer 2 is around 0.57 (p.u). This behavior of the conventional line-interactive UPS system is observed under the inverter mode operating condition of the UPS system and is shown in Fig. 4.

B. PROPOSED SINGLE-PHASE LINE-INTERACTIVE UPS SYSTEM OPERATING UNDER TRANSFORMER-COUPLED LOADING CONDITIONS

The basic illustration of the proposed line-interactive UPS system operating under transformer-coupled loading conditions is shown in Fig. 5 (a). Here, the load transformers are provided to ensure isolation for the sensitive loads. In the given figure, it is shown that the UPS system consists of a

bypass switch, an inverter that supplies backup power of the battery in the event of a utility failure, an isolation transformer to provide isolation to the load and inverter of the UPS system, and an LC filter to suppress the output voltage and current ripples in order to facilitate the control process for the controller. A circuit breaker is provided so that load 2 can be switched on and off depending upon the manufacturing forecast and schedule.

In normal mode, the load is supplied power by the utility via a bypass switch and an isolation transformer. When sagging occurs on the utility side, the proposed UPS system begins to operate in compensation mode, and the inverter injects compensation power to the load to keep the load power constant. However, the bypass switch opens during power outages. The inverter uses the battery’s backup

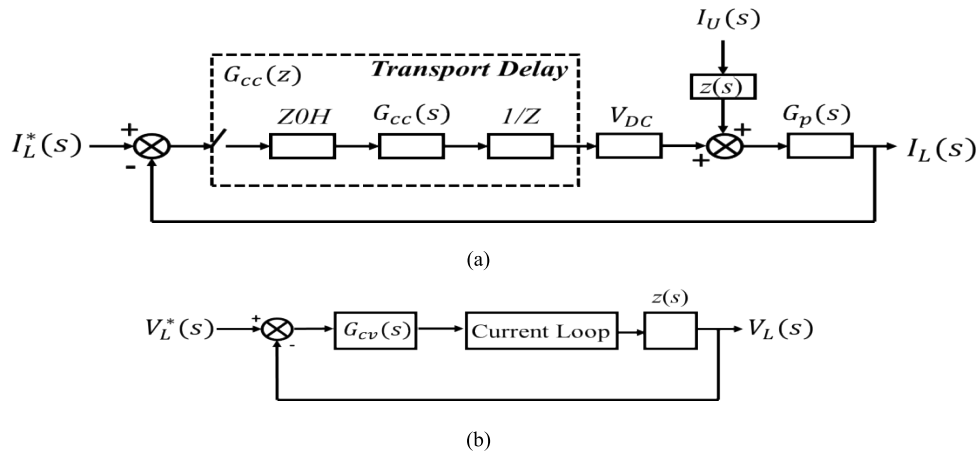

FIGURE 6. Average value model representation for the proposed UPS system: (a) current control loop, and (b) voltage control loop.

power to fully power the load during inverter mode of operation.

A comprehensive drawing of the developed single-phase line-interactive UPS system operating under transformer-coupled loading conditions is presented in Fig. 5(b). Moreover, the controller of the UPS system includes two control loops. The outer voltage loop generates a reference signal I_L^* for the inner current control loop by controlling the load voltage V_L and comparing it with the reference load V_L^* . However, the inner control loop controls the load current I_L by increasing or decreasing its magnitude based on the ratings of the switching-on and -off of loads.

The basic proportional-integral (PI) controller with proportional control commanding high-frequency fast system response and integral control reduces the steady-state error to achieve excellent control of DC current. However, when dealing with the AC current, its performance is less satisfactory. Under these conditions, in order to achieve a high controller gain at a certain frequency, a current regulation scheme is employed, which is processed in the P + resonant controller implemented in the $d-q$ synchronous frame of reference.

In this article, the inverter of the anticipated UPS system comprises of a basic current-control algorithm attained using a PI controller via a stationary frame of reference, which was well proved and evaluated in [39], [40]. The most important goals of using this current regulator are (1) simpler and easier than other approaches such as $d-q$ rotating frames with alterations or P + resonant control-based schemes; and (2) in many cases, the performance of the PI current regulator used in the fixed reference frame can be substantially improved, and the gain limit introduced by the controller can be greatly compressed by the proven simple feedforward compensation method [40].

Fig. 6 (a) portrays the block diagram of an “average model” integrated in single-phase line-interactive UPS system. In this figure, $E_c(s)$ and $I_L^*(s)$ represents the feedback error, and rated load current, respectively. The PWM

modulator is omitted and replaced with a linear amplifier having a forward gain. Moreover, $I_U(s)$ and $I_L(s)$ represents the utility sag current demonstrated as an input current injection attained through simple circuit theory, and the regulated output current of an inverter to achieve the load current at the steady-state, respectively. Equation (7) portrays the proposed UPS system in the form of a transfer equation:

$$I_L(s) = \frac{I_U(s)G_p(s)}{1 + G_{cc}(s)V_{DC}G_p(s)} + \frac{I_L^*(s)G_{cc}(s)V_{DC}G_p(s)}{1 + G_{cc}(s)V_{DC}G_p(s)} \quad (7)$$

where $G_p(s)$ is used to represent the plant’s transfer function, $G_{cc}(s)$ is the current controller transfer function, and V_{DC} is the forward gain of the linear amplifier.

The controller $G_{cc}(s)$ in this system is used to equalize the output currents $I_L(s)$ as close as possible to the rated load currents $I_L^*(s)$, while diminishing error due to the switch-on of the load transformers. In addition, to achieve this goal, the forward-path gain $G_p(s)G_{cc}(s)V_{DC}$ is made as large as possible. To represent an “average model”, circuit theory generates the following R/L “plant” transfer function:

$$G_p(s) = \frac{1}{R(1 + sT)}, \quad T = L/R \quad (8)$$

where $L(s)$, and $R(s)$ represents the load inductance and the load resistance, respectively. The transfer function of the PI regulator $G_{cc}(s)$ is as follows:

$$G_{cc}(s) = K_P \left(1 + \frac{1}{s\tau_r} \right) \quad (9)$$

where τ_r represents an integrator reset time and is equal to:

$$\tau_r = \frac{K_p}{K_i} \quad (10)$$

By using (8) and (9), the open-loop forward path gain of the proposed system becomes

$$G_p(s)G_{cc}(s) = \frac{V_{DC}K_P}{R\tau_r} \left(\frac{1 + s\tau_r}{s(1 + sT)} \right) \quad (11)$$

Equation (11) portrays the second-order system comprises of one zero and two poles. This system has a phase response, an asymptote of -90° at high frequencies, making it ideally stable regardless of PI controller gain K_p . However, the real system is unstable before the proportional gain is high enough to achieve an acceptable controller performance.

Therefore, it is necessary that the ‘‘average model’’ confines the PI controller proportional gain and includes the properties of the second-order properties. The most likely candidates are the sampling delays by the digital converter control system and transmission delays by the PWM process. The total transfer and sampling delays for the algorithm used in an inverter are approximately 0.75 of the carrier period delay i.e., $T_d = 0.75\Delta T$. The control loop delays can be demonstrated in two ways. In first, to model the transport delay, the $1/z$ element is used in series with the controller. The other way includes the modeling of sampling delay by using the Z-transform theory incorporated with an element of zero-order hold (ZOH), as presented in Fig. 6(a). Moreover, a strategy consisting of two steps is used for calculating the values of PI controller gains. These steps allow calculating the gain values optimized for any particular system. This strategy involves of obtaining (1) the minimum value of the integrator time constant and (2) the maximum value for the proportional gain of the PI controller while considering the effects of transport and sampling delays and maintaining the phase margin of ϕ_m as the forward path open-loop gain tracks through unity [33], [34]. The proportional (K_p) and integral (K_i) gains of the PI controller are 5 and 0.5, respectively.

The mean value model diagram representing the inner and external control loops for the employed control scheme of the proposed single-phase line-interactive UPS system is presented in Fig. 6(b). However, under these conditions, the systems overall transfer function would be:

$$V_L(s) = \left[\frac{I_U(s)G_p(s)}{1 + G_{cc}(s)V_{DC}G_p(s)} + \frac{I_L^*(s)G_{cc}(s)V_{DC}G_p(s)}{1 + G_{cc}(s)V_{DC}G_p(s)} \right] * [G_{cv}(s)z(s)V_L^*(s)] \quad (12)$$

where $V_L(s)$, $V_L^*(s)$, $z(s)$, and $G_{CV}(s)$ represents the output voltage of compensator, reference load voltage, load impedance, and the transfer function of the PI regulator of the voltage loop, respectively [42]–[46].

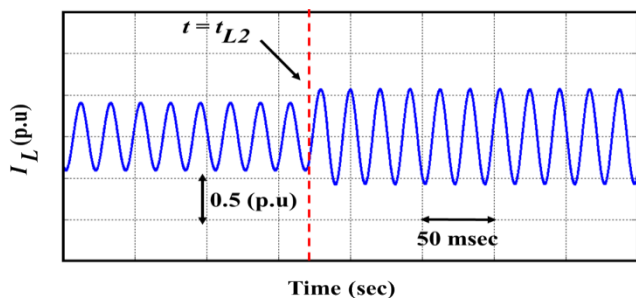

FIGURE 7. The load current of the proposed single-phase line-interactive UPS system for transformer-coupled loading conditions.

Fig. 7 illustrates the behavior of the proposed single-phase line-interactive UPS system operating under

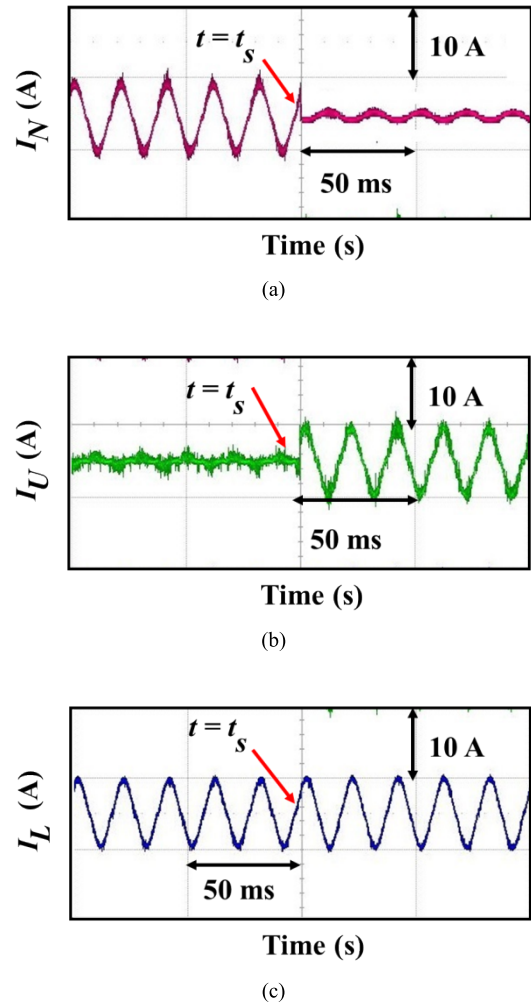

FIGURE 8. Experimental waveforms of the (a) inverter, (b) utility, and (c) load currents during the normal operating mode.

transformer-coupled loading conditions. For better comparative analysis, the proposed and conventional single-phase line-interactive UPS systems are investigated under similar operating, loading, and transient conditions. Assuming the load transformer 1 is online, and load transformer 2 is offline. If $t = t_{L2}$, load transformer 2 is connected to the system via circuit breaker. The output current I_L of the proposed line-interactive UPS system increases from 0.42 (p.u) and reaches a peak of 0.57 (p.u) above the rated load current after connecting load transformer 2. This eradicates the chances of inrush current when turning on the load transformer 2.

IV. EXPERIMENTAL RESULTS

To verify the competency of the proposed UPS system, a prototype is developed, having various parameters as tabulated in Table 1.

For the implementation of a control strategy, a DSP control board DSPTMS320F28335 and a custom-based inverter are used. Voltage and current sensors are employed to sample the magnitudes of output current I_L and voltage V_L in

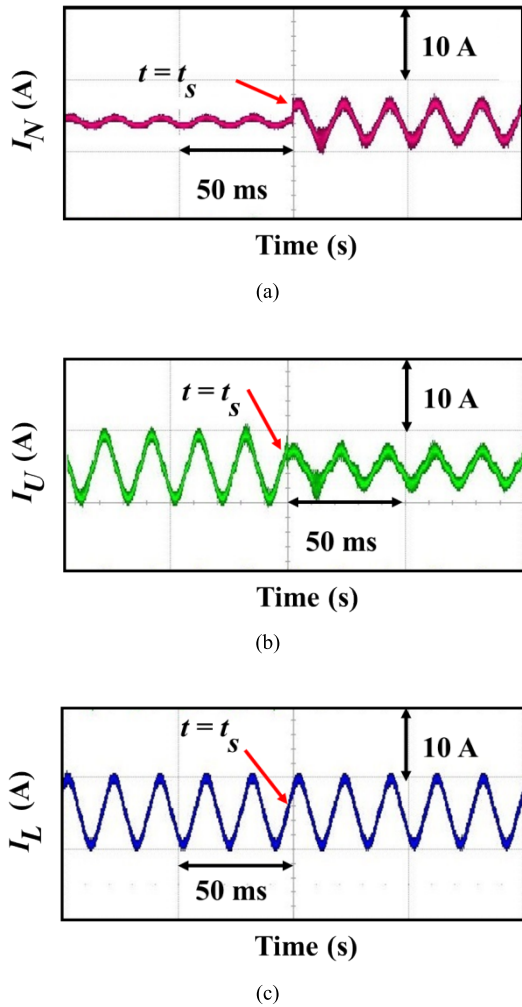

FIGURE 9. Experimental waveforms of the (a) inverter, (b) utility, and (c) load currents during compensation mode.

TABLE 1. System Parameters.

Parameter	Value
Utility	220 V, 60 Hz
Inverter Switching Frequency	10 kHz
DC Bus Voltage	365 V
Load Transformers 1 and 2	500 VA, 220/220 V
Load 1	$R_L = 160 \Omega$ and $L_L = 21.5$ mH
Load 2	$R_L = 224 \Omega$
Filter Inductance and Capacitance	$L_f = 0.265$ mH, $C_f = 0.1$ μ F

order to use them as feedback signals for the current and voltage loops, respectively. The operation of the proposed single-phase line-interactive UPS system is first investigated during all the possible operating conditions i.e., normal, inverter, and compensation modes. Fig. 8 shows the experimental results of the proposed UPS system during the normal operating mode. Here, the proposed system is initially working in inverter mode. However, at a particular instant

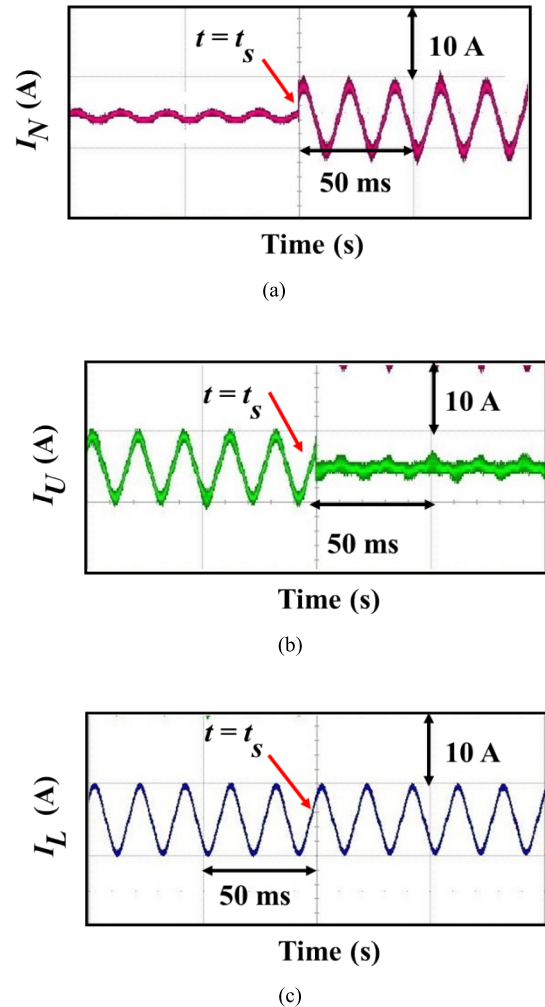

FIGURE 10. Experimental waveforms of the (a) inverter, (b) utility, and (c) load currents during inverter mode.

when $t = t_s$, the utility becomes normal and the inverter starts decreasing its output current (I_N) to shift the load completely to the utility. The compensation mode of the proposed UPS system is depicted in Fig. 9. Here, the grid goes under the faulty condition, and the utility current (I_U) decreases around 40% of the load current (I_L). Under such a condition, the proposed UPS system start operating in compensation mode and the inverter starts injecting the 40% of the load current to keep the load current constant. Fig. 10 shows the operation of the proposed UPS system in inverter mode. Under this mode of operation, the inverter takes over the load completely as any blackout occurs at the utility side.

The proposed UPS system operating under multiple transformer-coupled loading conditions is investigated under the worst transient and loading condition, i.e., inverter mode.

The experimental results are depicted in Fig. 11. In the beginning, the magnitude of current shows that the inverter of the UPS system is powering the load 1. At $t = t_{L2}$, another load called load 2 is merged into the system via circuit

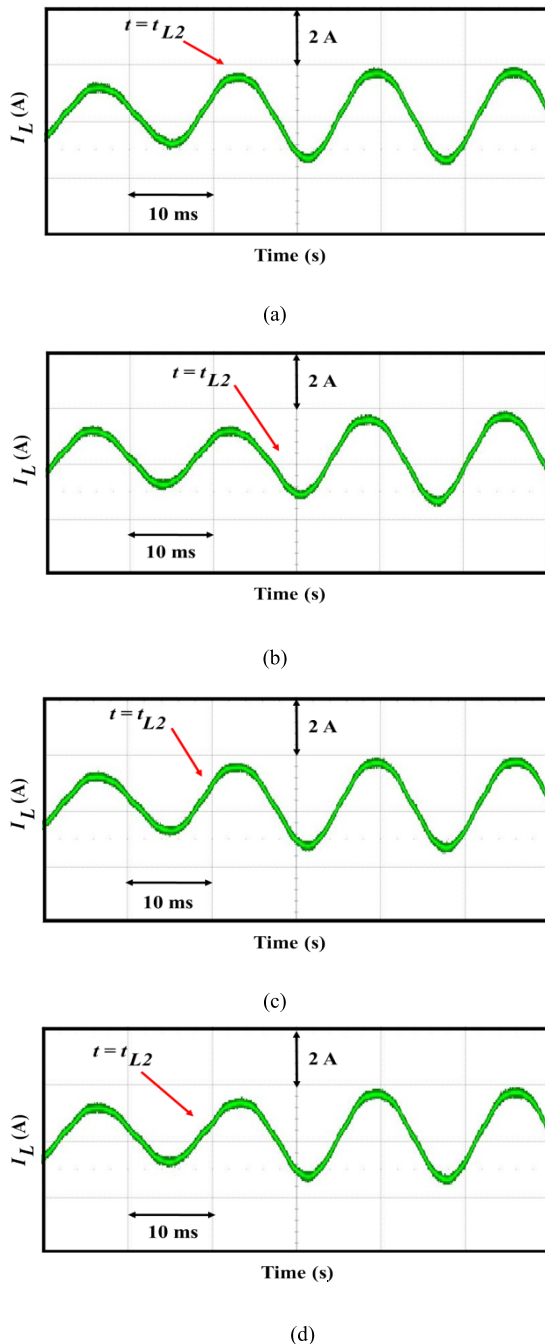

FIGURE 11. Experimental results for the proposed single-phase line-interactive UPS system when load 2 is turned on at (a) 30° , (b) 120° , (c) 240° , and (d) 270° .

breaker, ultimately increasing the magnitude of current from the value of 1 A to 1.4 A. Hence, the possibilities of inrush current due to the energization of the load transformer 2 are mitigated. Moreover, the switching conditions of the load transformer affects the magnitude of inrush current. Hence, the system is operated at different switching moments.

Fig. 11 shows the performance of the proposed UPS system when load transformer 2 is turned on at angles of 30° ,

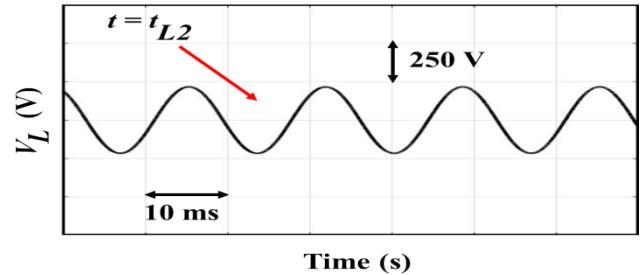

FIGURE 12. Load voltages for the proposed single-phase line-interactive UPS system when load 2 is turned on.

120° , 240° , and 270° . The experimental results show that the performance of the proposed single-phase line-interactive UPS system is not affected by the operating conditions of the load transformer. Moreover, the magnitude of the load current increases sinusoidally without the generation of an inrush transient current at the investigated switching-on conditions of load transformer 2. Fig. 12 shows the load voltages for the proposed single-phase line-interactive UPS system when load 2 is turned on.

V. CONCLUSION

In this paper, a single-phase line-interactive UPS system for multiple transformer-coupled loading conditions was proposed. The inverter of the proposed UPS system was able to change the magnitude of the output current according to the switching-on and -off ratings of the load using a control strategy implemented in a stationary frame of reference. The operation of the UPS system was verified during all the possible operating conditions i.e., normal, compensation and inverter modes. However, the operation of the proposed UPS system with transformer-coupled loads was demonstrated by the experimental results during different switching conditions of the load transformer.

From the results, it is concluded that the operation of the proposed UPS system is not only seamless, but it also eliminates the generation of inrush transient current during the turning on of the transformer-coupled loads.

REFERENCES

- [1] S. S. H. Bukhari, S. Atiq, T. A. Lipo, and B.-I. Kwon, "Line-interactive UPS system that eliminates the inrush current phenomenon," *Electric Power Compon. Syst.*, vol. 44, no. 11, pp. 1203–1214, Jun. 2016.
- [2] M.-K. Yang, S.-J. Lee, and W.-Y. Choi, "High-efficiency non-isolated dynamic voltage restorer using soft-switching dc-dc converter for parallel-voltage compensation," in *Proc. IEEE Energy Convers. Congr. Expo. (ECCE)*, Montreal, QC, Canada, Sep. 2015, pp. 2407–2412.
- [3] Y.-H. Chen, C.-Y. Lin, J.-M. Chen, and P.-T. Cheng, "An inrush mitigation technique of load transformers for the series voltage sag compensator," *IEEE Trans. Power Electron.*, vol. 25, no. 8, pp. 2211–2221, Aug. 2010.
- [4] S. S. H. Bukhari, S. Atiq, T. A. Lipo, and B.-I. Kwon, "A cost-effective, single-phase line-interactive UPS system that eliminates inrush current phenomenon for transformer-coupled loads," *J. Electr. Eng. Technol.*, vol. 11, no. 3, pp. 675–682, May 2016.
- [5] M. B. Shamsheh, T. Yoshino, and A. Kawamura, "Current-dependent capacitor voltage control of parallel autonomous UPS systems," *IEEE Trans. Ind. Electron.*, vol. 65, no. 4, pp. 2873–2882, Apr. 2018.

- [6] B. Wei, A. Marzabal, R. Ruiz, J. M. Guerrero, and J. C. Vasquez, "DAVIC: A new distributed adaptive virtual impedance control for parallel-connected voltage source inverters in modular UPS system," *IEEE Trans. Power Electron.*, vol. 34, no. 6, pp. 5953–5968, Jun. 2019.
- [7] S. Kim, M. Kwon, and S. Choi, "Operation and control strategy of a new hybrid ESS-UPS system," *IEEE Trans. Power Electron.*, vol. 33, no. 6, pp. 4746–4755, Jun. 2018.
- [8] B. Wei, Y. Gui, S. Trujillo, J. M. Guerrero, and J. C. Vasquez, "Distributed average integral secondary control for modular UPS systems-based microgrids," *IEEE Trans. Power Electron.*, vol. 34, no. 7, pp. 6922–6936, Jul. 2019.
- [9] Q. Lin, F. Cai, W. Wang, S. Chen, Z. Zhang, and S. You, "A high-performance online uninterruptible power supply (UPS) system based on multitask decomposition," *IEEE Trans. Ind. Appl.*, vol. 55, no. 6, pp. 7575–7585, Nov. 2019.
- [10] S. S. H. Bukhari, T. A. Lipo, and B.-I. Kwon, "An online UPS system that eliminates the inrush current phenomenon while feeding multiple load transformers," *IEEE Trans. Ind. Appl.*, vol. 53, no. 2, pp. 1149–1156, Mar./Apr. 2017.
- [11] S. Khan, S. S. H. Bukhari, and J.-S. Ro, "Design and analysis of a 4-kW two-stack coreless axial flux permanent magnet synchronous machine for low-speed applications," *IEEE Access*, vol. 7, pp. 173848–173854, 2019.
- [12] S. Madanzadeh, A. Abedin, A. Radan, and J.-S. Ro, "Application of quadratic linearization state feedback control with hysteresis reference reformer to improve the dynamic response of interior permanent magnet synchronous motors," *ISA Trans.*, to be published.
- [13] S. S. H. Bukhari, T. A. Lipo, and B. Kwon, "An inrush current reduction technique for the line-interactive uninterruptible power supply systems," in *Proc. 39th Annu. Conf. IEEE Ind. Electron. Soc. (IECON)*, Nov. 2013, pp. 430–434.
- [14] S. Karve, "Three of a kind [UPS Topologies, IEC Standard]," *Proc. Inst. Elect. Eng. Rev.*, vol. 46, no. 2, pp. 27–31, Mar. 2000.
- [15] B.-H. Kwon, J.-H. Choi, and T.-W. Kim, "Improved single-phase line-interactive UPS," *IEEE Trans. Ind. Electron.*, vol. 48, no. 4, pp. 804–811, Aug. 2001.
- [16] M. M. Zaid and J.-S. Ro, "Switch ladder modified H-bridge multilevel inverter with novel pulse width modulation technique," *IEEE Access*, vol. 7, pp. 102073–102086, 2019.
- [17] S. Bukhari, S. Atiq, and B.-I. Kwon, "Elimination of the inrush current phenomenon associated with single-phase offline UPS systems," *Energies*, vol. 9, no. 2, p. 96, Feb. 2016.
- [18] S. Bukhari, S. Atiq, T. Lipo, and B.-I. Kwon, "Asymmetrical fault correction for the sensitive loads using a current regulated voltage source inverter," *Energies*, vol. 9, no. 3, p. 196, Mar. 2016.
- [19] C.-C. Yeh and M. D. Manjrekar, "A reconfigurable uninterruptible power supply system for multiple power quality applications," *IEEE Trans. Power Electron.*, vol. 22, no. 4, pp. 1361–1372, Jul. 2007.
- [20] T. Kawabata, T. Miyashita, N. Sashida, and Y. Yamamoto, "Three phase parallel processing UPS using multi-functional inverter," *IEEE Ind. Appl. Soc. Annu. Meeting Conf.*, vol. 1, Oct. 1989, pp. 982–987.
- [21] J.-C. Wu and H.-L. Jou, "A new UPS scheme provides harmonic suppression and input power factor correction," *IEEE Trans. Ind. Electron.*, vol. 42, no. 6, pp. 629–635, Dec. 1995.
- [22] S. Ohn, J. Yu, P. Rankin, B. Sun, R. Burgos, D. Boroyevich, H. Suryanarayana, and C. Belcastro, "Three-terminal common-mode EMI model for EMI generation, propagation, and mitigation in a full-SiC three-phase UPS module," *IEEE Trans. Power Electron.*, vol. 34, no. 9, pp. 8599–8612, Sep. 2019.
- [23] S. Zhao, N. Khan, S. Nagarajan, and O. Trescases, "Lithium-ion-capacitor-based distributed ups architecture for reactive power mitigation and phase balancing in datacenters," *IEEE Trans. Power Electron.*, vol. 34, no. 8, pp. 7381–7396, Aug. 2019.
- [24] B. Wei, A. Marzabal, J. Perez, R. Pinyol, J. M. Guerrero, and J. C. Vasquez, "Overload and short-circuit protection strategy for voltage source inverter-based UPS," *IEEE Trans. Power Electron.*, vol. 34, no. 11, pp. 11371–11382, Nov. 2019.
- [25] W.-Y. Choi and M.-K. Yang, "Transformerless line-interactive UPS with low ground leakage current," *IEEE Trans. Ind. Electron.*, vol. 65, no. 12, pp. 9468–9477, Dec. 2018.
- [26] G. Joos, Y. Lin, P. D. Ziogas, and J. F. Lindsay, "An online UPS with improved input-output characteristics," in *Proc. IEEE Appl. Power Electron. Conf. Expo. (APEC)*, Feb. 1992, pp. 598–605.
- [27] Y. Joos, G. Lindsay, and J. F. Lindsay, "Performance analysis of parallel-processing UPS systems," in *Proc. IEEE Appl. Power Electron. Conf. Expo. (APEC)*, Mar. 1993, pp. 533–539.
- [28] S. Rathmann and H. A. Warner, "New generation UPS technology, the delta conversion principle," in *Proc. 31st IEEE Ind. Appl. Soc. Annu. Meeting Conf.*, vol. 4, Oct. 1996, pp. 2389–2395.
- [29] F. Kamran and T. Habetler, "A novel on-line UPS with universal filtering capabilities," *IEEE Trans. Power Electron.*, vol. 13, no. 3, pp. 410–418, May 1998.
- [30] S. J. Jeon and G. H. Cho, "A series-parallel compensated uninterruptible power supply with sinusoidal input current and sinusoidal output voltage," in *Proc. 28th IEEE Power Electron. Specialists Conf.*, vol. 1, Jun. 1997, pp. 297–303.
- [31] S. A. O. Da Silva, P. F. Donoso-Garcia, P. C. Cortizo, and P. F. Seixas, "A three-phase line-interactive UPS system implementation with series-parallel active power-line conditioning capabilities," *IEEE Trans. Ind. Appl.*, vol. 38, no. 6, pp. 1581–1590, Nov./Dec. 2002.
- [32] H.-L. Jou, J.-C. Wu, C. Tsai, K.-D. Wu, and M.-S. Huang, "Novel line-interactive uninterruptible power supply," *Inst. Elect. Eng. Electric Power Appl.*, vol. 151, no. 3, pp. 359–364, May 2004.
- [33] F. Barrero, S. Martinez, F. Yeves, F. Mur, and P. Martinez, "Universal and reconfigurable to UPS active power filter for line conditioning," *IEEE Trans. Power Del.*, vol. 18, no. 1, pp. 283–290, Jan. 2003.
- [34] M. Arias, M. M. Hernando, D. G. Lamar, J. Sebastián, and A. Fernández, "Elimination of the transfer-time effects in line-interactive and passive standby UPSs by means of a small-size inverter," *IEEE Trans. Power Electron.*, vol. 27, no. 3, pp. 1468–1478, Mar. 2012.
- [35] S. Martinez, M. Castro, R. Antoranz, and F. Aldana, "Off-line uninterruptible power supply with zero transfer time using integrated magnetics," *IEEE Trans. Power Electron.*, vol. 36, no. 3, pp. 441–445, Aug. 1989.
- [36] H. Mokhtari, M. Iravani, and S. Dewan, "Transient behavior of load transformer during subcycle bus transfer," *IEEE Trans. Power Del.*, vol. 18, no. 4, pp. 1342–1349, Oct. 2003.
- [37] P.-T. Cheng, W.-T. Chen, Y.-H. Chen, C.-L. Ni, and J. Lin, "A Transformer inrush mitigation method for series voltage sag compensators," *IEEE Trans. Power Electron.*, vol. 22, no. 5, pp. 1890–1899, Sep. 2007.
- [38] R. D. Doncker, D. W. J. Pülle, and A. Veltman, *Advanced Electrical Drives: Analysis, Modeling, Control* (Power Systems). Heidelberg, Germany: Springer-Verlag, 2011.
- [39] D. G. Holmes, T. A. Lipo, B. P. McGrath, and W. Y. Kong, "Optimized design of stationary frame three phase AC current regulators," *IEEE Trans. Power Electron.*, vol. 24, no. 11, pp. 2417–2426, Nov. 2009.
- [40] W. Y. Kong, D. G. Holmes, and B. P. McGrath, "Improved stationary frame AC current regulation using feedforward compensation of the load EMF," in *Proc. 24th Annu. IEEE Appl. Power Electron. Conf. Expo.*, Washington, DC, USA, Feb. 2009, pp. 145–151.
- [41] M. Jamali, M. Mirzaie, and S. A. Gholamian, "Calculation and analysis of transformer inrush current based on parameters of transformer and operating conditions," *Electron. Elect. Eng. J.*, vol. 109, no. 3, pp. 17–20, 2011.
- [42] J. C. Chapman, *Electric Machinery Fundamentals*, 5th ed. New Delhi, India: McGraw-Hill, 2017.
- [43] S. S. H. Bukhari and B.-I. Kwon, "A single-phase on-line UPS system for multiple load transformers," *IEICE Electron. Express*, vol. 14, no. 5, Mar. 2017, Art. no. 20170050.
- [44] S. S. H. Bukhari, S. Atiq, and B.-I. Kwon, "A sag compensator that eliminates the possibility of inrush current while powering transformer-coupled loads," *IEEE J. Emerg. Sel. Topics Power Electron.*, vol. 5, no. 2, pp. 891–900, Jun. 2017.
- [45] S. S. H. Bukhari, M. Ayub, and B.-I. Kwon, "A three-phase line-interactive UPS system to eliminate the inrush current phenomenon during switching-in of an auxiliary load while powering the main load," *J. Elect. Eng. Technol.*, vol. 13, no. 4, pp. 1623–1630, Jul. 2018.
- [46] F. A. Chachar, S. S. H. Bukhari, F. H. Mangi, D. E. Macpherson, G. P. Harrison, W. Bukhsh, and J.-S. Ro, "Hierarchical control implementation for meshed AC/multi-terminal dc grids with offshore windfarms integration," *IEEE Access*, vol. 7, pp. 142233–142245, 2019.



SYED SABIR HUSSAIN BUKHARI (Member, IEEE) was born in Khairpur Mir's, Sindh, Pakistan, in 1986. He received the B.E. degree in electrical engineering from the Mehran University of Engineering and Technology, Jamshoro, Pakistan, in 2009, and the Ph.D. degree from the Department of Electronic Systems Engineering, Hanyang University, South Korea, in 2017. He joined Sukkur IBA University as an Assistant Professor, in December 2016. He is currently

working as a Research Professor with Chung-Ang University, Seoul, South Korea, under Korean Research Fellowship (KRF) Program. His main research interests include electric machine design, power quality, and drive controls.



JONG-SUK RO (Member, IEEE) received the B.S. degree in mechanical engineering from the Han-Yang University, Seoul, South Korea, in 2001, and the Ph.D. degree in electrical engineering from Seoul National University (SNU), Seoul, South Korea, in 2008.

He conducted research at the Research and Development Center of Samsung Electronics as a Senior Engineer, from 2008 to 2012. From 2012 to 2013, he was with the Brain Korea 21 Information Technology of SNU, as a Postdoctoral Fellow. He conducted research at the Electrical Energy Conversion System Research Division, Korea Electrical Engineering and Science Research Institute, as a Researcher, in 2013. From 2013 to 2016, he worked with the Brain Korea 21 Plus, SNU, as a BK Assistant Professor. In 2014, he was with the University of Bath, Bath, U.K. He is currently an Associate Professor with the School of Electrical and Electronics Engineering, Chung-Ang University, Seoul, South Korea. His research interests include the analysis and optimal design of next-generation electrical machines using smart materials such as electromagnet, piezoelectric, magnetic shape memory alloy, and so on.

• • •