

Received July 22, 2021, accepted September 5, 2021, date of publication September 13, 2021, date of current version September 22, 2021.

Digital Object Identifier 10.1109/ACCESS.2021.3112189

# A Comprehensive Review on Structural Topologies, Power Levels, Energy Storage Systems, and Standards for Electric Vehicle Charging Stations and Their Impacts on Grid

MOHD RIZWAN KHALID<sup>1</sup>, (Member, IEEE), IRFAN A. KHAN<sup>2</sup>, (Senior Member, IEEE),  
SALMAN HAMEED<sup>1</sup>, (Member, IEEE), M. SYED JAMIL ASGHAR<sup>1</sup>, (Member, IEEE),  
AND JONG-SUK RO<sup>3,4</sup>

<sup>1</sup>Department of Electrical Engineering, Aligarh Muslim University, Aligarh 202002, India

<sup>2</sup>Clean And Resilient Energy Systems (CARES) Laboratory, Texas A&M University at Galveston, Galveston, TX 77553, USA

<sup>3</sup>School of Electrical and Electronics Engineering, Chung-Ang University, Dongjak-gu, Seoul 06974, Republic of Korea

<sup>4</sup>Department of Intelligent Energy and Industry, Chung-Ang University, Dongjak-gu, Seoul 06974, Republic of Korea

Corresponding author: Jong-Suk Ro (jongsukro@gmail.com)

This work was supported in part by the Basic Science Research Program through the National Research Foundation of Korea funded by the Ministry of Education under Grant 2016R1D1A1B01008058, and in part by the Human Resources Development of the Korea Institute of Energy Technology Evaluation and Planning (KETEP) Grant funded by the Korea Government Ministry of Trade, Industry and Energy under Grant 20204030200090.

**ABSTRACT** The penetration of electric vehicles (EVs) in the transportation sector is increasing but conventional internal combustion engine (ICE) based vehicles dominates. To accelerate the adoption of EVs and to achieve sustainable transportation, the bottlenecks need to be elevated that mainly include the high cost EVs, range anxiety, lack of EV charging infrastructure, and the pollution of the grid due to EV chargers. The high cost of EVs is due to costly energy storage systems (ESS) with high energy density. This paper provides a comprehensive review of EV technology that mainly includes electric vehicle supply equipment (EVSE), ESS, and EV chargers. A detailed discussion is presented on the state-of-the-art of EV chargers that include on-/off-board chargers. Different topologies are discussed with low-/high-frequency transformers. The different available power levels for charging are discussed. To reduce the range anxiety the EV chargers based on inductive power transfer (IPT) are discussed. The last part of the paper focuses on the negative impact of EV chargers along with the remedies that can be adopted. The international standards decided by different institutions and adopted universally are discussed in the latter part of this paper and finally, this paper concludes with the near to future advancement in EV technology.

**INDEX TERMS** Charge depletion, charge sustaining, electric vehicle, internal combustion engine, power factor, power quality.

## I. INTRODUCTION

The economic and social development depends mainly on the existing transportation sector in the country [1]. At present, internal combustion engine (ICE) based vehicles have domination in this sector. The tailpipe emissions and exhaust from these directly affect the climate and the pollutants aids in reducing the air quality which has adverse results on human health and the ecosystem [2], [3]. The transportation sector

The associate editor coordinating the review of this manuscript and approving it for publication was Zhigang Liu<sup>1</sup>.

is responsible for about 24% of the total CO<sub>2</sub> that results from the combustion of fossil fuel [4]. Figure 1 shows the sector-wise emission of CO<sub>2</sub> from the combustion of fuel and is likely to increase with urbanization, industrialization, and with an increase in the number of vehicles, in the coming future [5]. To reduce the aforementioned concerns, there is a need to find an alternative for the transportation sector.

The inclusion of electric vehicles (EVs) in the transportation sector is the bright option for reducing tailpipe emissions that can improve the air quality and therefore reduce the adverse effects of ICE-based vehicles [1]. Moreover, EVs are

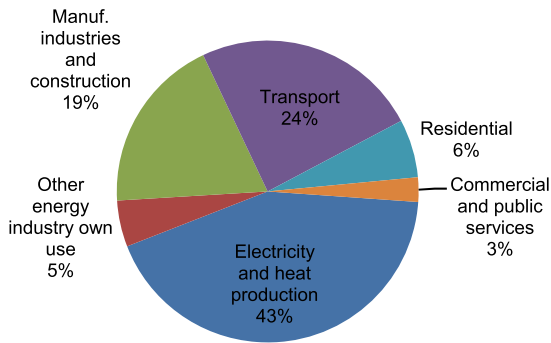


FIGURE 1. Sector-wise CO<sub>2</sub> emission from fuel combustion [5].

comparatively efficient, have better performance, and have a lower driving cost per mile, as compared to ICE-based vehicles. The electric motor that drives EVs utilizes 80-85% of the total energy that is supplied through the batteries compared to 12-30% that the ICE-based vehicles utilize [6]. Further, the tank-to-wheel efficiency of EVs is higher than that of the ICE-based vehicle, as shown in Figure 2.

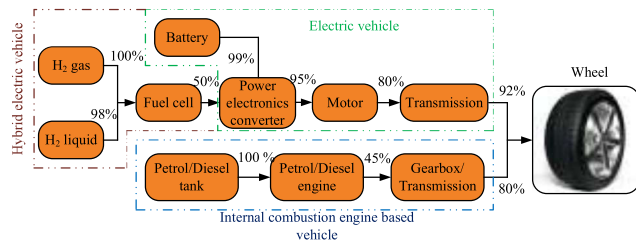


FIGURE 2. Efficiencies of different vehicles.

On 5<sup>th</sup> December 2015, 195 countries participated in Paris Climate Conference and adopted the first ever universally and legally adopted agreement on climate change [7]. In the conference, amid growing concerns on climate change were addressed and the governmental policies to endorse the use of electricity in the transportation sector were proposed. Presently, the transportation sector contributes to 24% of the total CO<sub>2</sub> emitted by mankind and this figure is going to increase at an alarming rate with an increase in urbanization and industrialization [4].

Shifting from petroleum or fossil fuel-based transportation to an electricity-based transportation system has evolved an idea of EVs that are powered through an on-board energy storage system (ESS) and the latter is being powered by electricity. The battery storage must be capable of supplying the energy demands of the EV. Recent research and advancements in technology over the last couple of years have suggested the use of Li-ion batteries in EVs [8], [9]. Despite improvements in Li-ion batteries, the energy density is 200–300 Wh/kg which is much low in comparison to petroleum (13,000 Wh/Kg). Due to this, the driving range of an EV is limited in one complete charge of battery and there is always a “range anxiety”, i.e. a fear of having no charge and also unable to charge at the desired moment [6].

Another bottleneck in the wide adoption of EVs is the lack of proper EV charging infrastructure that can replace and compete with the existing refueling stations [10], [11]. In addition to this, the deployed charging infrastructure must avoid the deleterious harmonic effects on the electric utility distribution system [12], [13]. Therefore, the development of the EV charging infrastructure parallel to the existing refueling station with minimal impact on the existing electric utility distribution system is urgently required particularly in the regions where long driving is required (highways). Moreover, the developed EV charging infrastructure must incorporate the industry standards, available technology along with the government policies [14].

The EV charging infrastructure is mainly categorized into two categories, (a) inductive power transfer (IPT) or wireless power transfer (WPT) and (b) conductive power transfer. Both have their own merits and demerits over each other. Further, these are subdivided into on-board and off-board charging infrastructures [15], [16]. In on-board EV charging infrastructure the EV charger circuitry is placed inside the EV along with the ESS, while, in off-board EV charging infrastructure, the charging circuitry is not an integral part of the EV.

The main idea of this paper is to develop the off-board charging infrastructure that can be deployed similar to the refueling stations and can elevate the bottleneck in the vast adoption of EVs due to the lack of availability of proper EV charging infrastructure. Moreover, the developed EV charging infrastructure is reliable; robust; modular in nature; cost comparative and satisfies IEEE 519-2014 power quality (PQ) standards.

Further, this paper provides an introduction to different types of EVs that are available commercially and discusses the technology for the ESS. The in-depth review on the electric vehicle supply equipment (EVSE) which includes mainly EV charging cords, residential and public charging stands, plugs, power outlets with different recommended power levels by the society of automotive engineers (SAE) is presented. In the latter part of this paper, a comprehensive state-of-the-art review of the available topologies for the EV charging stations is presented along with their negative impacts on the electric utility distribution system. Finally, the technical codes and standards for safety and isolation conclude this paper.

## II. CLASSIFICATION OF EVs

Based on the combination of electrical and fuel energy that drives them EVs are broadly classified into three main categories [17].

### A. BATTERY ELECTRIC VEHICLE (BEV)

A battery electric vehicle (BEV) is based only on an electric motor and ESS and does not need the support of traditional ICE. They are plugged into an electrical supply to recharge their ESS (batteries) when they are exhausted. BEVs can also recharge their batteries through the regenerative braking

process, which uses the vehicle's electric motor to assist in slowing down the vehicle and to recover the energy which is usually converted to heat energy by the brakes [18].

Some commercially available BEVs are Tesla Model S, Nissan Leaf, BMW i3, Mitsubishi iMiEV, Smart EV, Ford Focus EV, etc. The main advantages of BEVs are:

- Zero tailpipe emissions.
- No need for gas or oil refueling.
- Easy to be charged at home.
- Fast and smooth acceleration.
- Overall low cost of operation.

Apart from the advantages, some disadvantages are:

- Shorter drive range as compared to ICE-based vehicles.
- Expensive than ICE-based vehicles, however, the pay-back period from fuel savings is only about 2-3 years.

### B. PLUG-IN HYBRID ELECTRIC VEHICLE (PHEV)

The plug-in hybrid electric vehicle (PHEV) uses an electric motor and ESS along with the ICE. The feature of having ICE in PHEV makes it a more suitable and promising option for long-distance journeys. The operation of PHEV is divided mainly into two modes; namely, charge depleting (CD) mode and charge sustaining (CS) mode. In CD mode, PHEV disables its ICE and draws vehicle driving energy entirely from the battery until it reaches a threshold state-of-charge (SOC), where SOC is a quantity that measures the percentage of remaining charge in the battery. Upon reaching the minimum SOC, PHEVs switch their operation to CS mode and the IC engine provides energy to drive the vehicle as well as to maintain battery charge above but near to the minimum SOC. For better fuel efficiency, a third mode, called charge blended (CB) mode has been introduced, in which electric motor and IC engine are optimally and dynamically employed during a drive cycle so that they are able to operate longer using the most efficient settings while achieving an overall reduction in the emissions [19]. Commonly available PHEVs are BMW i3, BMW i8, Cadillac ELR, GM Chevy Volt, Porsche SE, Ford Fusion Energi, Ford Cmax Energi, Toyota Prius Plugin. The advantages of PHEVs are:

- Long driving range.
- Low fuel consumption than conventional ICE-based vehicles.
- Low emission of pollutants in the environment.

Some disadvantages of PHEVs are:

- Environmental pollution is not eliminated.
- Expensive to operate as compared to BEVs.

### C. HYBRID ELECTRIC VEHICLE (HEV)

Hybrid electric vehicles (HEVs) have two driving systems, ICE with a fuel tank and an electric motor with an ESS. Both, ICE and the electric motor drive the vehicle at the same time. However, HEVs do not have the facility of charging from the utility grid, all their driving energy comes from the fuel and the regenerative braking process in the vehicle [20], [21]. Some commonly available HEVs are Audi

Q5 Hybrid, Acura ILX Hybrid, Cadillac Escalade Hybrid, BMW Active Hybrid 3, BMW Active Hybrid 5, BMW Active Hybrid 7, Honda Civic Hybrid, Honda CR-Z Hybrid. Some advantages of HEVs are:

- Longer driving range than BEVs.
- Lower fuel consumption compared to ICE-based vehicles.
- Lower emissions than ICE-based engines.

Some disadvantages of HEVs are:

- Zero tailpipe emission is not achieved.
- The mechanism of operation is complex.
- Expensive to operate as compared to BEVs.
- Cheaper compared to ICE-based vehicles.

Figure 3 shows the architecture of BEVs, PHEVs, and HEVs that explains the working mechanisms. It is estimated that energy consumption per mile for all EVs lies approximately in the range of (0.25 - 0.45) kWh/mile, Table 1.

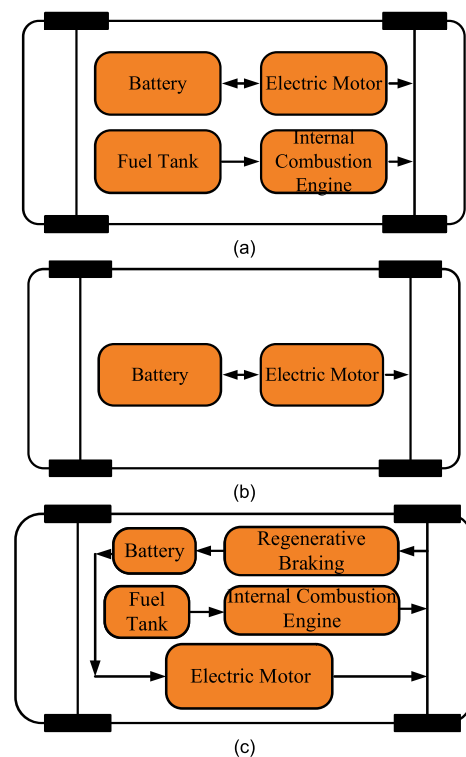


FIGURE 3. Architecture of (a) PHEVs. (b) BEVs. (c) HEVs.

### III. ENERGY STORAGE SYSTEM (ESS)

To make EVs suitable for long-distance journeys, the ESS (batteries) in the EVs should meet criteria in terms of high energy density for extending the driving range of EVs; high power density for the fast acceleration of EVs; a large number of life cycles; wide range of temperature in which they can operate and low maintenance, the capability of accepting high power repetitive charges from regenerative braking operation [22].

The rate at which a battery is charged depends directly on the internal DC resistance (DCR) of each cell, the chemistry

**TABLE 1.** EVs energy consumption [15].

Vehicle class	Energy consumption per mile (kWh/mile)	PHEV-30 (kWh)	PHEV-40 (kWh)
Compact sedan	0.26	7.8	10.4
Mid-size sedan	0.30	9.0	12.0
Mid-size SUV	0.38	11.4	15.2
Full-size SUV	0.46	13.8	18.4

involved in it, and the charging techniques used to charge the battery. In an ideal battery, the value DCR should have a low value to achieve high efficiency with low heat generation. Batteries used in EV applications require more safety precautions because frequent fast charge/discharge operations in EV battery leads to the generation of excessive heat. There are several types of batteries that are commercially available and currently used in various EVs [23]. The different types of chemistries involved in the batteries of EVs are discussed below.

#### A. NICKEL-METAL HYDRIDE (NiMH) BATTERIES

These batteries have high energy and power densities as compared to conventional lead-acid batteries. However, these batteries have poor performances at extremely high and low temperatures and also require frequent maintenance. As the EVs require high-capacity batteries with the capability of many deep discharge cycles, these batteries are not suitable for EV applications.

#### B. NICKEL-CADMIUM (NiCD) BATTERIES

Nickel-Cadmium (NiCD) batteries are suitable for deep discharge cycle applications and have better performances at high temperature operating conditions. However, NiCD batteries have low energy density and contain an appreciable amount of toxic metals which limits their use in EV applications.

#### C. LITHIUM-ION (LI-ION) BATTERIES

Lithium-Ion (Li-ion); Lithium-Ion Polymer and Lithium-Iron Phosphate batteries have high energy density and due to which these are lighter in weight in comparison to other batteries, this makes it most suitable for EVs applications.

Typically, lithium-ion batteries have four major chemistries based on cathode materials, namely; cobalt, manganese, nickel-cobalt-manganese, and phosphate utilizing either carbon or graphite as an anode. Among these, cobalt oxide which has the highest energy density (Wh/kg) is found thermally unstable, and its internal resistance varies considerably with time and depends on the energy output, resulting in a reduced cycle life [24]. On the other hand, manganese oxide has low cost, high energy density, and safety but has limitations in terms of limited operating temperature and low volumetric energy density [25].

New lithium-ion chemistry is iron-phosphate that delivers high currents and offers a large number of life cycles as compared to other available technologies. However, its energy capacity is lower than other lithium chemistries, but these batteries are capable of maintaining their nameplate capacity longer than any other technology due to the low and stable value of internal DC resistance. Table 2 compares the performance parameters of different batteries [23].

### IV. CHARGING TECHNIQUES OF ESS

Charging of ESS depends on the rate of transfer of energy, for EV owners it is desirable to utilize fast charging techniques at high power levels to charge the EVs battery in less time. The chemistry involved in a battery determines the power level at which it can be charged [37].

Furthermore, the charging methods/techniques adopted are also responsible for the fast charging of EVs. Several charging techniques are discussed below:

#### A. CONSTANT CURRENT-CONSTANT VOLTAGE (CC-CV) MODE

Constant current-constant voltage (CC-CV) mode is the conventional method of charging. The main idea of this technique is to charge the EV battery a constant maximum current (recommended by the manufacturer) up to some threshold (cut-off) voltage and then the battery is charged at this threshold voltage, till the battery starts charging at around C/10 or less of the defined capacity. CC-CV charging profile of a battery is shown in Figure 4(a) [37].

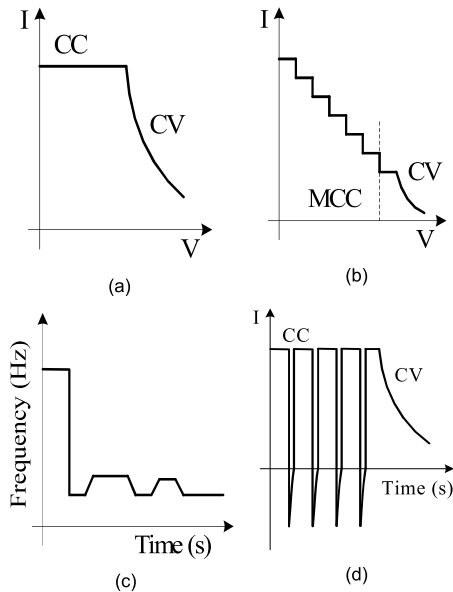
#### B. MULTISTAGE CONSTANT CURRENT-CONSTANT VOLTAGE (CC-CV) MODE

Multistage constant current-constant voltage (MCC-CV) mode is a modified CC-CV mode that increases the charge acceptance rate of the battery. The basic principle is the same as that of CC-CV mode with the exception that in CC-CV mode only one constant current level is used till the threshold voltage level, while in MCC-CV mode many current steps are applied up to the threshold voltage, shown in Figure 4(b).

The above-stated charging methods are traditional and have limitations in their capability to deliver high power due to polarization. The new charging methods that reduce the effect of polarization, and thus increase the charging acceptance, are still being the active area for the researchers. Discharging the battery at specific time intervals during

**TABLE 2.** Performance parameters of different EES [25], [36].

Type	Energy Efficiency (%)	Energy Density (Wh/Kg)	Power Density (W/Kg)	Life Cycles (cycles)	Self-Discharge
Pb-Acid	70 - 80	20 - 35	25	200 - 2000	Low
Ni-Cd	60 - 90	40 - 60	140 - 180	500 - 2000	Low
Ni-MH	50 - 80	60 - 80	220	<3000	High
Li-ion	70 - 85	100 - 200	360	500 - 2000	Medium
Li-polymer	70	200	250 - 1000	>1200	Medium



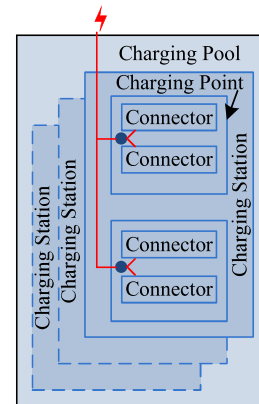
**FIGURE 4.** Traditional and advanced charging techniques.

charging is one method to increase charge acceptance [38]. This method is applicable to both CC-CV and MCC-CV modes in order to yield a superior result. An advanced way of CC-CV mode with negative pulses is shown in Figure 4(c). Another approach discussed in [39] uses a variable pulse charge strategy, in which optimal pulse charge frequency is continuously calculated and optimized in order to distribute the ions in electrolytes evenly. Between the pulses, a variable rest period is given that neutralizes and diffuses the ions. This rest period is predefined by the maximum power point tracker (MPPT) to determine the maximum current that can be given for a given SOC in real-time. Typical characteristics of the variable frequency associated with pulse charging are shown in Figure 4(d). Incorporation of this method increases the charge acceptance as compared to the conventional CC-CV and fixed frequency pulse charging method.

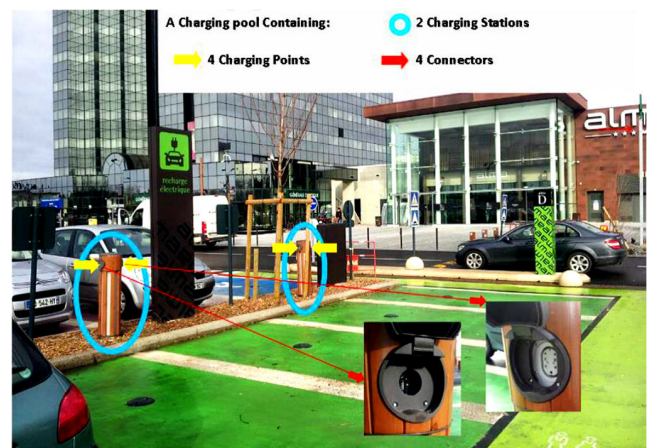
**V. ELECTRIC VEHICLE SUPPLY EQUIPMENT (EVSE)**

The electric vehicle supply equipment (EVSE) provides electric power to recharge the battery of EV. EVSE is commonly known as EV charging stations or EV charging points [16]. EVSE includes the electrical power conductors, related equipment, software, and communications protocols that deliver the electrical energy efficiently and safely from

the electric utility distribution system to the ESS of the EVs. Figure 5 shows the block diagram of a charging pool that has several EV charging stations. A charging pool contains several charging stations, while a charging station contains several charging points. Each charging point has several connectors and per charging point not more than one connector can be active at a time [40]. A photograph of a typical charging pool is shown in Figure 6 [16].



**FIGURE 5.** Block diagram of charging pool.



**FIGURE 6.** Photograph of a typical charging pool.

**A. CHARGING POOL**

A charging pool consists of single/multiple charging stations and the parking bays, shown in Figure 6. The charging

pool is operated by one charge point operator (CPO) and a global positioning system (GPS) coordinates at a location. The charging pool is related to “cartographic view”, guiding tools, and the features that represent a charging infrastructure on a map.

**B. CHARGING STATION**

A Charging Station is a physical structure having one or more charging points that share a common user identification interface (UII). Some charging stations have radio-frequency identification (RFID) readers, displays, and LEDs, while others are only ‘Plug & Charge’, and do not have buttons, displays, etc.

**C. CHARGING POINT**

The electric energy is delivered to the EV through the charging point. A charging point has one or many connectors to accommodate different types of connectors (discussed latter). As shown in Figure 6, only one connector is used at a time.

**D. CONNECTORS**

The connector is a physical interface between EV and its charging station that provides electricity for the charging purpose, as shown in Figure 6. Different types of connectors are discussed and explained in the latter part of this paper.

**VI. CLASSIFICATION OF EV CHARGERS**

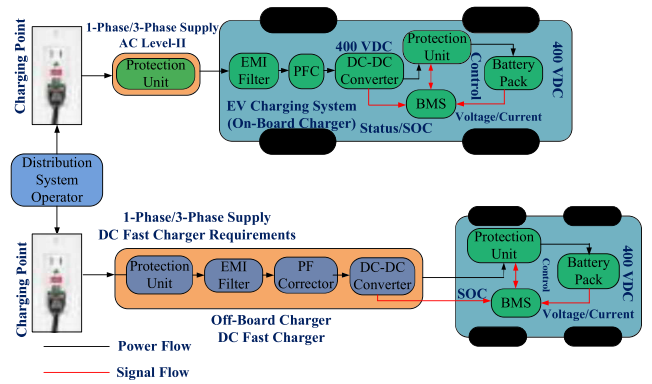
Charging of EV requires either single-phase or three-phase chargers with unidirectional or bidirectional power flow capabilities [16], [41]–[43]. EV chargers are classified into conductive and inductive chargers. Conductive charging technology is well developed while inductive charging technology remains the hot topic for researchers.

**A. CONDUCTIVE CHARGING**

Conductive charging involves direct metal-to-metal contact between the utility grid and the EV to transfer the power. This method of charging is found to be highly efficient and robust. Conductive chargers are classified as on-board and off-board charging infrastructures. On-board chargers are integrated with the EV, due to constraints on weight, space, size, and cost power level of these types of chargers are limited [44], [45]. On the other hand, off-board EV chargers have no constraints on their size, weight, and space since they are not an integral part of EV and are installed in public parking bays like those of hospitals, shopping malls, and universities. Figure 7 shows the block diagram that highlights the difference between on-board and off-board chargers. On-board chargers are generally used for slow charging purposes while off-board chargers are intended for fast charging.

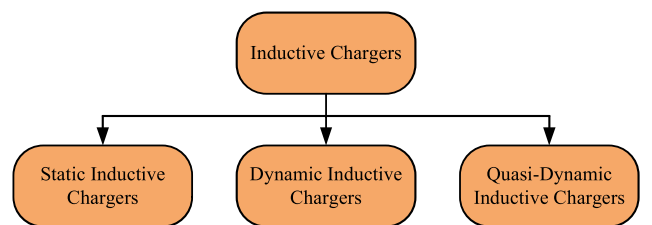
**B. INDUCTIVE CHARGING**

Inductive or wireless chargers work on the principle of IPT, i.e. mutual induction to transfer power from the utility grid to the EV. It requires no physical contact between the utility grid and EV. Moreover, they may or may not require isolation



**FIGURE 7. On-board and Off-board conductive charging infrastructures.**

transformers for safety purpose, thus it has reduced size as compared to the conductive chargers [46]. However, inductive chargers are comparatively less efficient due to misalignment between the power transferring coils. Inductive chargers are classified into three categories, a) static inductive chargers, b) dynamic inductive chargers, and c) quasi-dynamic inductive chargers [47]–[50], confer Figure 8. Figure 9 shows the schematic of static and roadbed inductive chargers for charging EVs wirelessly. Static inductive chargers have two coils; one is installed in the charger, i.e. outside the EV while the other coil is an integral part of the EV. To achieve high efficiency both coils are aligned properly. Roadbed inductive charging has the ability to charge the EV when it is in motion. In this charging method, special charging tracks are laid on the roads (usually highways) that are capable of charging the EV and reduce the range anxiety and capacity of ESS. In quasi-dynamic inductive charging, the EV is charged whenever it stops for a small interval, like on traffic signals.



**FIGURE 8. Classification of inductive chargers.**

**C. UNIDIRECTIONAL AND BIDIRECTIONAL CHARGERS**

Between EV and the utility grid, two possible types of power flow are shown in Figure 10. EVs with unidirectional chargers charge the EV but do not inject the energy of EV into the utility grid. These chargers generally have a diode bridge rectifier (DBR) along with filter and dc-dc converters. Nowadays these converters are realized as a single-stage that limits size, weight, cost, and losses [51]. High-frequency isolation transformers are employed to get the isolation during charging of EV [57]. Simple control of the unidirectional chargers makes them an easy option for a utility to manage a fleet

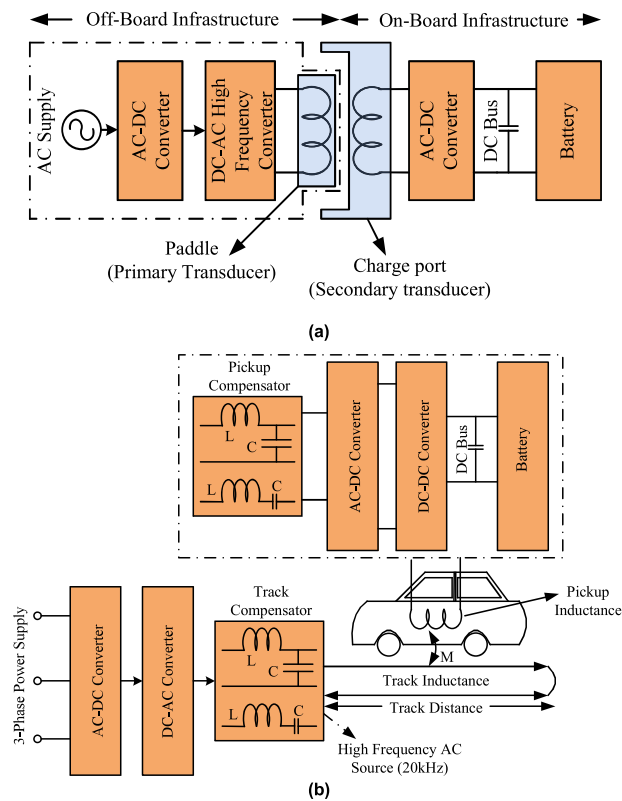


FIGURE 9. Schematic of (a) stationary inductive charging and (b) roadbed inductive charging.

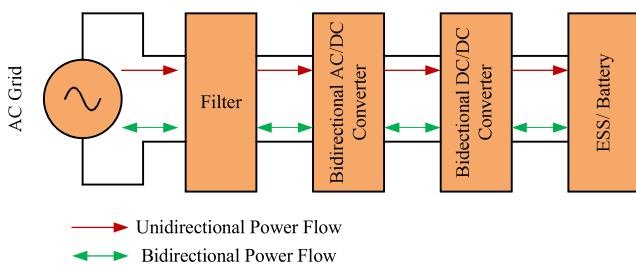


FIGURE 10. Unidirectional and bidirectional charger topology.

of EVs [42]. Chargers having active front ends have the ability to provide reactive power support through the current phase angle control without discharging the battery. With increased penetration of EVs in the utility grid and active charging current control, unidirectional chargers seem to be a promising solution to meet most utility objectives while avoiding the cost, safety, and performance concerns that are associated with the bidirectional chargers [58], [59].

On the other hand, a bidirectional charger has two power stages; one is an active grid-connected bidirectional ac-dc converter that endorses unity power factor (PF), and the second is a bidirectional dc-dc converter that regulates the charging current [52], [57]. These chargers utilize both isolated and non-isolated circuit configurations. When charging the EV, they must draw sinusoidal current from the utility grid with a

defined phase angle to control real and reactive power. While in discharge mode, the charger must be capable of returning the power to the grid with the required PF [60], [61].

Figure 11 shows the classification of unidirectional and bidirectional chargers. Among these single-phase chargers are used for slow charging purposes while three-phase chargers are utilized in fast charging of EVs. Isolated chargers include diode bridge rectifiers (DBR) along with Flyback/ Forward/ Push-pull/ SEPIC/ CUK/ Multilevel circuit configurations, while non-isolated chargers include DBR along with Buck/ Boost/ Buck-Boost circuit configurations.

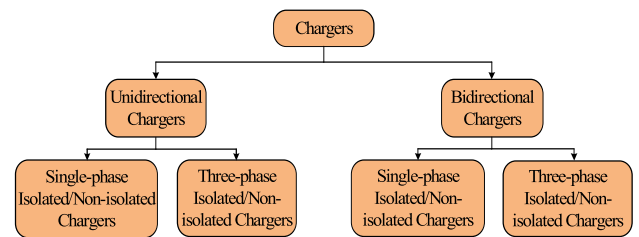


FIGURE 11. Classification of inductive chargers.

## VII. CHARGING POWER LEVELS OF EV

Charging power levels of EVs reflect power, charging duration, cost, location, equipment, and its effect on the utility grid. Deployment of charging infrastructure and EVSE is a complex aspect due to many issues that need to be resolved: charging time, demand policies, standardization of policies for charging stations, and regulatory procedures. Availability of proper charging infrastructure may reduce on-board ESS requirements and costs drastically.

As mentioned earlier, the charging cord, charging stand (residential or public), attachment plugs, power outlets, EV connectors, and protection equipment are major components of EVSE. These are categorized in two configurations: one as a specialized cord set, and the other as a wall or pedestal mounted box. However, the specific configurations vary with location and country depending on utility supply voltage, frequency, grid connection, and transmission standards [62]. According to the electric power research institute (EPRI), most EVs are likely to charge at home during the night. For this reason, level-1 and level-2 charging seem to be the primary option. Table 3 summarizes the power levels for EV charging.

### A. LEVEL-1 CHARGING

Level-1 charging is categorized as slow charging. In the U.S., level-1 uses a 120 V/15 A standard single-phase grounded outlet, such as a NEMA 5-15R. The connection uses a standard J1772 connector into the EV as an ac port, shown in Figure 12 [64]. For domestic and commercial sites, no additional infrastructure is required. A cheaper charging rate is available during off-load periods, likely to be available at night.

**TABLE 3. Charging power levels [62].**

Power Level Type	Charger Location	Usage	Supply Interface	Power Level	Charging Time	Vehicle Technology
Level-1 120 VAC (U.S.) 230 VAC (E.U.)	On-Board 1-Phase	Domestic	Convenience outlet	1.4kW (12 A) 1.9kW (20A)	4-11 hours 11-36 hours	PHEVs (5-15kWh) EVs (16-50kWh)
Level-2 240 VAC (U.S.) 400 VAC (E.U.)	On-Board 1-/3-Phase	Private and Public	Dedicated EVSE	4kW (17A) 8kW (32A) 19.2kW (80A)	1-4 hours 2-6 hours 2-3 hours	PHEVs (5-15kWh) EVs (16-30kWh) EVs (3-50kWh)
Level-3 (208-600 VAC or VDC)	Off-Board 3-Phase	Commercial parallel to refueling stations	Dedicated EVSE	50kW 100kW	0.4-1 hours 0.2-0.5 hours	EVs (20-50kWh)

Level-1 charging is generally provided by the on-board chargers, up to a power level of 1.9kW through 120V single-phase AC supply. The acceptable charging current range is 15-20Amps. Depending on the ESS type and its capacity, level-1 charging usually takes about 3-20 hours to fully recharge the EV. As the standard electrical outlets are available almost everywhere and the charging time is long, the level-1 charging is particularly suitable for overnight charging which usually takes place at homes or in the parking bays of the large residential buildings. Chargers supporting this level of charging are usually on-board chargers.

**B. LEVEL-2 CHARGING**

Level-2 charging is the primary method of charging in public and private facilities. The chargers of this category can be on-board type to reduce power electronics. Existing level-2 chargers offer charging in the range of 208V or 240V (max 80 A, 19.2 kW). It requires dedicated equipment and installation for their deployment at the domestic and commercial level, EVs such as Tesla have the on-board power electronics and need only the outlet. Most U.S. homes have a 240V supply available and level-2 chargers charge the EV battery during the night. EV owners have an interest in level-2 chargers owing to their short charging time and standardized charger-to-vehicle connection. Installation cost of level-2 charger is around \$1000 to \$3000 [66]. The new standard has an SAE J1772 [64] ac charge connector on top and a two-pin dc connector below and is intended to enable either ac or dc fast charging via a single connection (confer Figure 12).

**C. LEVEL-3 CHARGING**

Level-3 is the future and has the ability to elevate the range anxiety and ESS of EVs. This offers commercial fast charging



**FIGURE 12. SAE's J1772 combo connector.**

that charges the EV in less than an hour. These chargers are installed along the highway sides parallel to the refueling stations. Level-3 chargers are usually off-board chargers and operate on 480V or higher three-phase supply. The connection to the vehicle may be direct dc. The dc plug intended for charging is shown in Figure 12. CHAdeMO, a Japanese protocol has gained international recognition for fast charging [67]. Cost of level-3 chargers ranges between \$30,000 to \$160,000 [68]. According to the SAE J1772 standard, level-1 and level-2 EVSE must be on-board, while level-3 EVSE must be off-board (located outside the EV). Generally, commercial EV charging stations are level-2 or 3 to enable fast charging.

A low-power charger has the added advantage of having minimum negative impacts on the utility grid during peak load periods. While, on the other hand, high power (level-3) chargers increase the demand and acts as an overload on the local distribution system, mainly during peak load periods. The various negative impacts of level-2 and 3 chargers are increased losses in distribution transformers, frequency deviation, voltage deviation, harmonic distortion, peak demand, and thermal loading of the distribution and transmission



TABLE 4. Charging characteristics and infrastructures of PHEVs and EVs.

Vehicle Name and Type	Battery Capacity	Connector Type	Level-1 Charging		Level-2 Charging		Level-3/ DC fast Charging	
			Demand	Charge Time	Demand	Charge Time	Demand	Charge Time
Toyota Prius PHEV	4.4 kWh	SAE J1772	1.4 kW (120V)	3 hours	3.8 kW (240V)	2.5 hours	NA	NA
Chevrolet Volt PHEV	16 kWh	SAE J1772	0.96-1.4 kW	5-8 hours	3.8 kW	2-3 hours	NA	NA
Tesla Roadster EV	53 kWh	SAE J1772	1.8 kW	30+ hours	9.6-16.8 kW	4-12 hours	NA	NA
Nissan Leaf EV	24 kWh	SAE J1772	1.8 kW	12-16 hours	3.3 kW	6-8 hours	50+kW	15-30 minutes

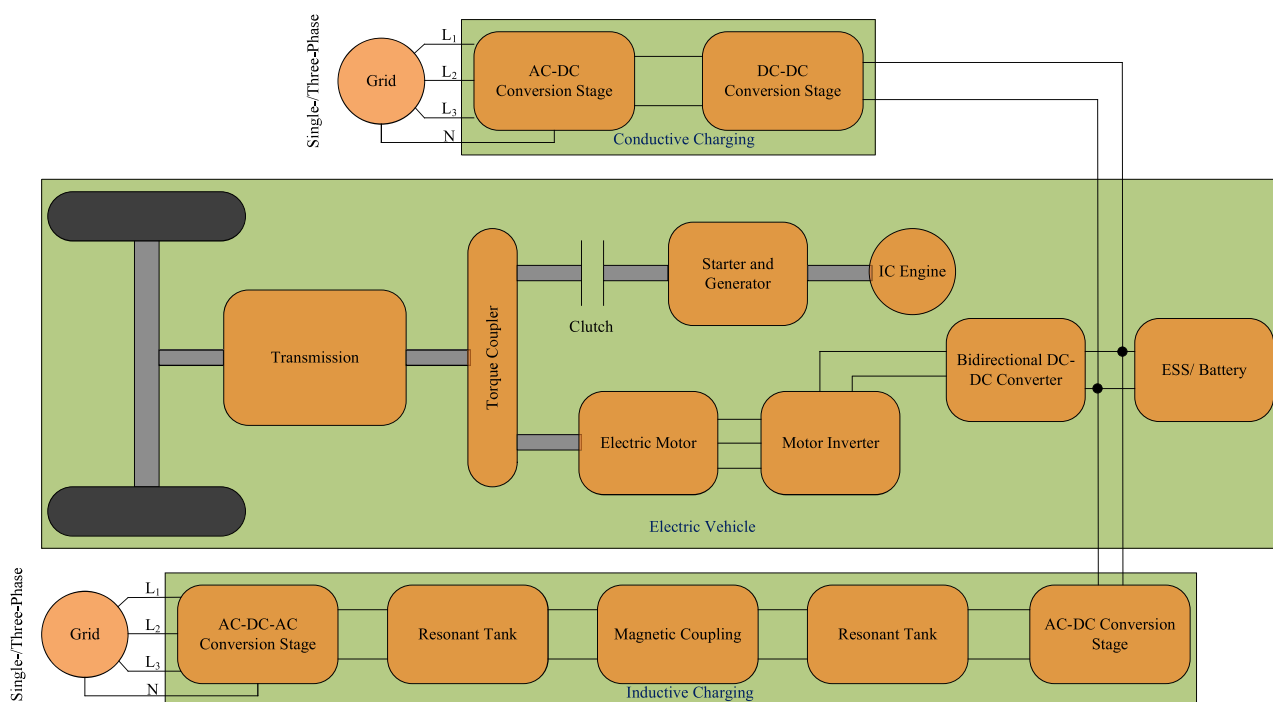


FIGURE 13. Power conversion stages of EV chargers.

system, mainly transformers. The degradation can be reduced significantly by opting for chargers with high PQ and deploying them with smart charging schemes [69]. The charging characteristics and infrastructure aspects for a few EVs are summarized in Table 4.

VIII. STATE-OF-THE-ART OF EV CHARGERS

This section focuses mainly on the topologies for on-board and off-board EV chargers. The ac-dc converter at the front-end is the key component of the EV charger. Various topologies and control techniques have been developed for PF correction applications [70]. The single-phase active PF correction technique is categorized as a single-stage and two-stage approach. A single-stage approach is suitable for low-power applications and has a low-frequency ripple in the output current. In addition, galvanic isolation for safety reasons is difficult. Thus, a two-stage approach is a proper choice for the EV chargers. Figure 13 shows the conductive

and inductive charging methods. As discussed earlier, the conductive chargers have a wired connection between the utility grid and power electronics interface (PEI) for charging and usually have a PF corrector, ac-dc rectifier followed by a dc-dc converter to regulate the charging. Contrary to this, inductive or wireless charging does not use a wired connection and the different power conversion stages are magnetically coupled. Depending on the location, EV chargers are classified as on-board and off-board chargers. The on-board charger resides on the EV and consists of mainly two power conversion stages, namely: (a) ac-dc converter to rectify utility single-/three-phase supply, and (b) dc-dc converter for regulating charging current. Off-board chargers fast and high-power chargers that are installed outside the EV. To reduce the size, weight, cost, and volume of on-board chargers, researchers have proposed the integration of chargers with the bidirectional dc-dc converter of EV that is used in the propelling unit. Thus, in this way a single-stage converter

is used for charging, motoring, and regenerative braking. Furthermore, integrated on-board EV chargers taking advantage of the motor windings and propulsion inverter have been proposed. The on-board and off-board charger topologies are mainly determined by the structure of the ac-dc converters and dc-dc converters. In this section various ac-dc and dc-dc converters presently used are presented.

### A. PF CORRECTOR AC-DC CONVERTER TOPOLOGIES

The ac-dc converter at the front-end of the EV charger converts the single-/three-phase utility supply to dc power and feeds to an intermediate dc link and also works as a PF corrector. Cost, robustness, PF, efficiency, control complexity, and total harmonic distortion (THD) in input line current drawn from the utility supply are the major factors that decide the selection of ac-dc converter for rectification and PF correction process. Boost type configurations and their derived variants are commonly used [71], [72]. The conventional boost ac-dc converter operating in continuous conduction mode (CCM) is the simplest ac-dc converter that has simple control and implementation. However, high conduction losses are the main limitations of this converter that is due to the current flowing through three semiconductor devices. The high-frequency (HF) operation poses an additional concern of the diode recovery losses. This requires the use of Schottky or SiC diodes, which increases the overall cost of the converter.

Symmetrical and asymmetrical bridgeless boost converters show improved efficiency over the conventional boost type ac-dc converter due to the reduced conducting power electronics devices; however, the issue of high diode reverse recovery losses remains [71]. Interleaving of two boost ac-dc converters doubles the switching frequency, thus the size of the filter and magnetic circuit reduces and energy density is improved. To increase the efficiency and to minimize the reverse recovery losses the soft switching technique seems to be promising [73]. The other variations of boost type circuit configurations are the half-bridge and full-bridge boost ac-dc converters. Although half-bridge configuration has the ability to achieve voltage doubling, they are comparatively costlier due to the requirement of higher voltage rating power electronics devices. On the other hand, the full-bridge boost ac-dc converter alleviates the issue of capacitor imbalance at the expense of increased power semiconductor devices, cost, and control complexity. For higher voltages (more than 400V), the three-level ac-dc boost converters are preferred.

### B. ISOLATED DC-DC CONVERTER TOPOLOGIES

The main objective of the dc-dc converter is to adjust the output of the front-end ac-dc converter and to charge the EV in desired mode (CC or CV). The most common dc-dc converter topologies include voltage-fed bridges; current-fed bridges; appropriate combinations of these; and resonant converters [74], [75]. The voltage- and current-fed full-bridge converter (VCFFB) is the widely used circuit configuration for charging an EV. Usually, zero voltage switching (ZVS) is achieved at the current-fed converters side, while zero current

switching (ZCS) is achieved for the voltage-fed converters. Dual active full bridges (DAFBs) with voltage-fed bridges on both primary and secondary sides are also widely employed. In DAFB configuration the active switch count and device stress is reduced in comparison to VCFFB.

### C. TWO-STAGE ON-BOARD EV CHARGERS

This section focuses on the on-board EV chargers that utilize the earlier mentioned rectifiers and dc-dc converters. The EV chargers consist of a current shaping stage that minimizes the THD in the input line current and achieves the unity PF followed by an isolated dc-dc converter for regulating the charging current. Figure 14, shows a 3.3 kW two-stage EV charger based on an interleaved ac-dc boost PF corrector followed by an isolated full-bridge dc-dc converter [76], [77]. The interleaved PF corrector is realized like two conventional boost converters working in continuous conduction mode (CCM), with each working at half of the full power. The interleaved structure has the ability to reduce the conduction losses, output capacitor ripples, and size of the filter circuit because devices are paralleled. The dc-dc converter at the second stage is implemented by using the full-bridge topology. In this, switches  $T_3$  and  $T_4$  are turned on at a fixed duty cycle of 50%, and  $T_1$  and  $T_2$  are pulse width modulated (PWM) on the trailing edge.

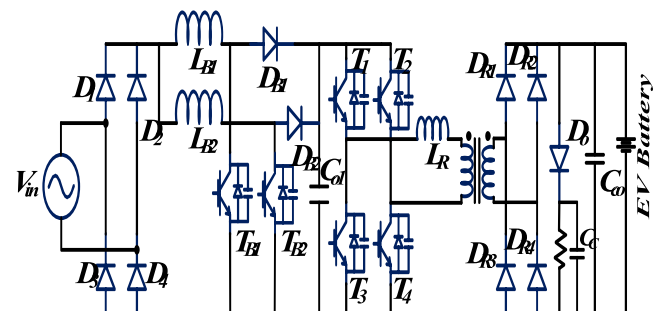


FIGURE 14. Interleaved boost PF corrector followed by the full-bridge dc-dc converter.

For the 0.75 turn-ratio of the transformer, 400 V is obtained at full load. The reported THD in input line current is less than 5% and a high PF of 0.99 is achieved. The peak efficiency reported was 93.6% at the switching frequency at 70 kHz in the front-end and 200 kHz in the dc-dc converter. The weight and volume of the charger are 6.2 kg and 5.5 L, respectively.

One major drawback of a conventional two-stage charger is the bulky dc-link capacitor and this needs to be reduced to increase the power density and to reduce the cost and the weight of the EV charger. To mitigate this problem a full-bridge LLC resonant converter with a boost PF corrector is reported in [78], shown in Figure 15. At the rated power of 3 kW, the efficiency of 93.6% is achieved with a high PF of 0.996.

Figure 16 shows an on-board charger using an HF resonant converter with a boost converter for regulating the charging of EV [79]. The experimental results showed an efficiency

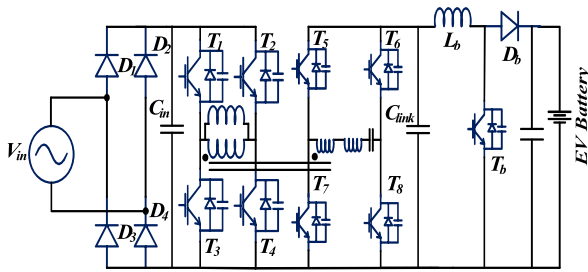


FIGURE 15. Resonant converter followed by boost PF corrector.

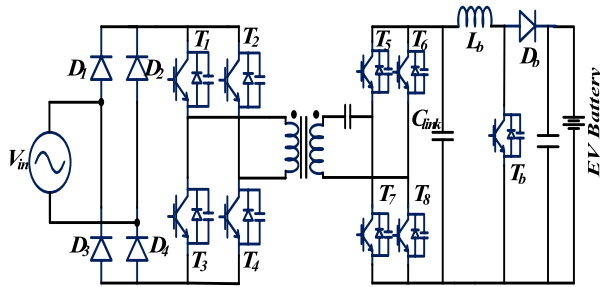


FIGURE 16. Full-bridge LLC resonant converter and synchronous rectifier followed by boost PF corrector.

of 92.5% at switching frequencies of 90 and 45 kHz for the resonant converter and the boost converter, respectively.

Another EV charger topology proposed in [80] is shown in Figure 17. It constitutes a PF corrector boost converter and a series resonant-loaded full-bridge dc-dc converter. The experimental result confirms efficiency of 93% with a high PF of 0.995. From the aforementioned on-board chargers, it is inferred that size, weight, and volume have a vital role in their selection.

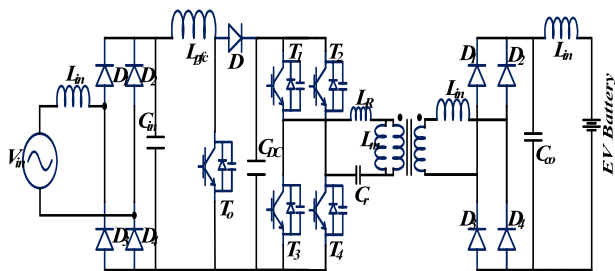


FIGURE 17. Boost PF corrector followed by a series-loaded resonant converter.

#### D. INTEGRATED ON-BOARD EV CHARGERS

Integrated EV chargers combine the charging stage with the bidirectional dc-dc converter that is used in EV to interface the ESS and inverter (confer Figure 13). In this way number of power electronics components is reduced and in turn, the size, weight, and cost of the EV charger are reduced.

Integrated on-board EV chargers offer the advantage of having a single converter with one inductor for all operation modes, i.e. charging, driving, and braking. With these

EV chargers, it is possible to charge the EV only when it is at rest. In [81], a single-stage converter is proposed that integrates the PEI, as illustrated in Figure 18. The proposed EV charger is a non-isolated buck-boost active rectifier with a common inductor which is shared with a bidirectional dc-dc converter of the EV. The charger has a wide range of input voltage and has the ability to assure unity PF while being operated in a buck mode (bridge- $T_1$ - $D_5$ ) and in a boost mode (bridge- $T_4$ - $T_2$ - $D_8$ - $T_5$ ) the input voltage during driving and steps down ( $T_6$ - $D_9$ - $D_6$ - $T_3$ - $D_5$ ) during the regenerative braking.

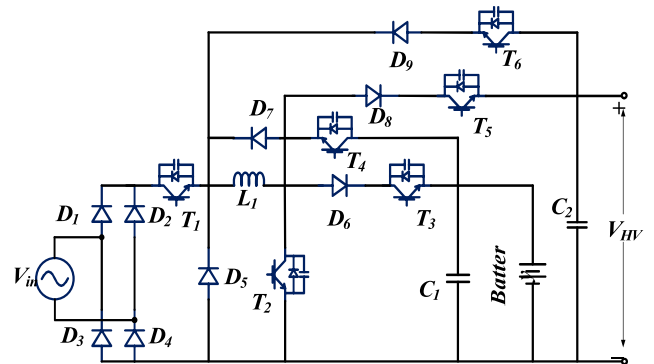


FIGURE 18. Buck-boost diode rectifier integrated with the dc-dc converter.

The drawback of this charger is that the ESS (battery) draws an oscillating charging current. Moreover, the charger draws input line current at high THD in absence of an input filter and therefore reduces the overall efficiency.

To attain low THD in input line current, a solution is proposed in [82], as shown in Figure 19. It constitutes a three-level ac-dc converter at the front-end interfaced with a dc-dc converter. It draws input line current at a low THD of 2.99% at an expense of a high number of power electronic active switches. Another solution proposed in [83] is shown in Figure 20, it constitutes a direct ac-dc converter with bidirectional switches. It has the ability to inject power back to the

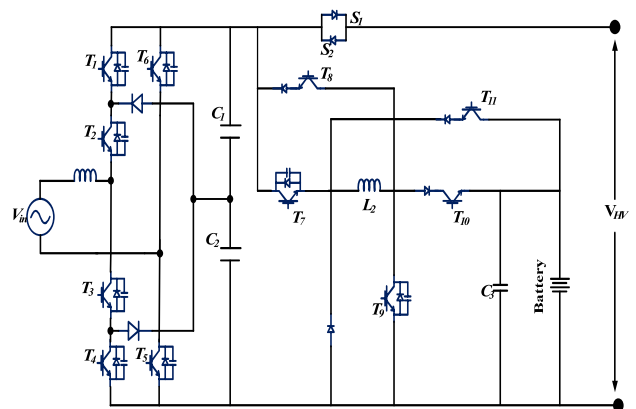
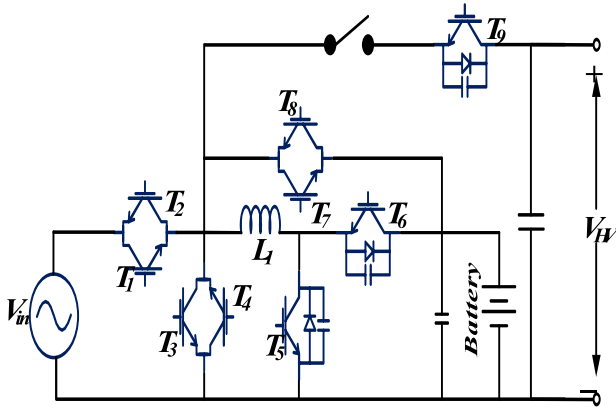


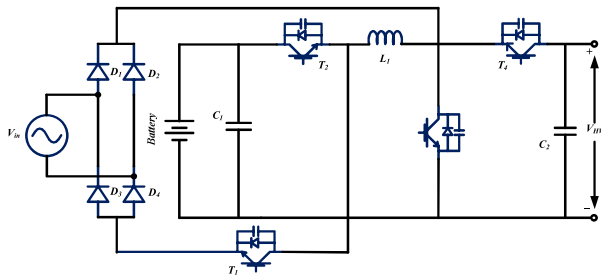
FIGURE 19. Three-level ac-dc front-end converter integrated with dc-dc converter.



**FIGURE 20.** Buck/boost bridgeless bidirectional ac-dc converter integrated with dc-dc converter.

grid in addition to driving, braking, and charging the EV with a common transfer inductor in all the modes. In comparison to the charger proposed in [82], it has higher complexity at an expense of V2G mode.

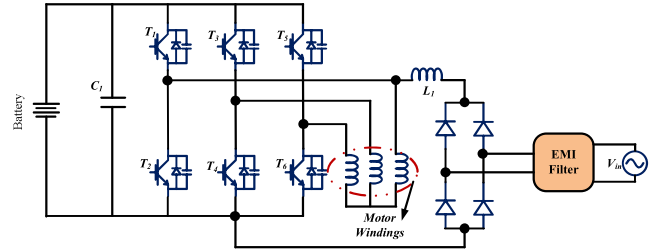
Figure 21 shows an EV charger proposed in [84] with a reduced number of active/passive components. The THD in the input line current obtained is low due to the line filters. An EV integrated charger discussed in [85] utilizes the motor's windings and dc-ac converter for charging. In this EV charger, the existing components of the drivetrain are reconfigured with minimum additional components to enable the charging. The PEI of the drivetrain is designed for high power ratings, thus these chargers have the flexibility of charging the EV from both single-/three-phase supplies. These chargers also offer the advantage of reduced weight and volume as the need for additional elements is elevated.



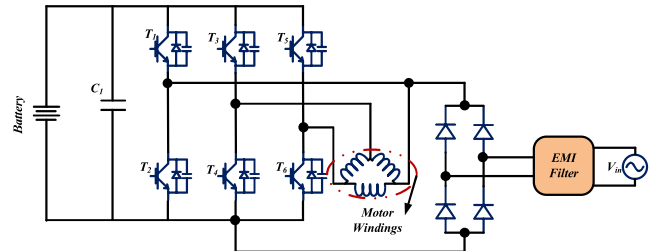
**FIGURE 21.** Buck-boost bridgeless direct ac/dc bidirectional converter integrated with dc/dc converter.

In [86], two solutions for integrating the drivetrain components for EV charging are proposed. The first solution, as shown in Figure 22 utilizes the motor inverter as an EV charger and an additional diode rectifier with an inductor. The motor windings in this EV charger are star-connected. The second solution is shown in Figure 23, which utilizes motor inverter and delta-wound motor windings, along with an additional diode bridge rectifier for EV charging. The advantages of these configurations include component reduction, and no need for relay circuits for transition between EV charging and propulsion.

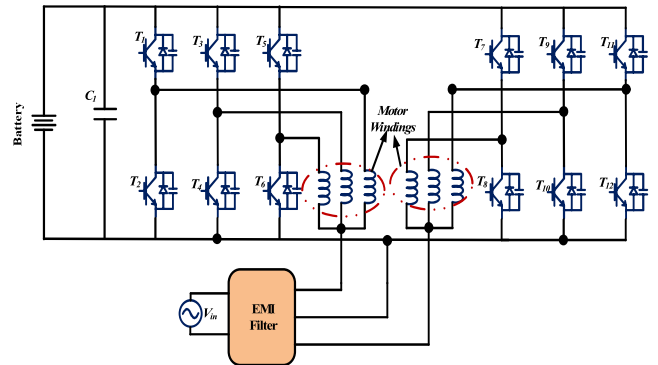
In [87], another solution based on the combination of motor driver/charger is proposed, as shown in Figure 24. This EV



**FIGURE 22.** Integrated EV charger utilizing motor inverter and star-connected windings with an additional diode bridge rectifier.



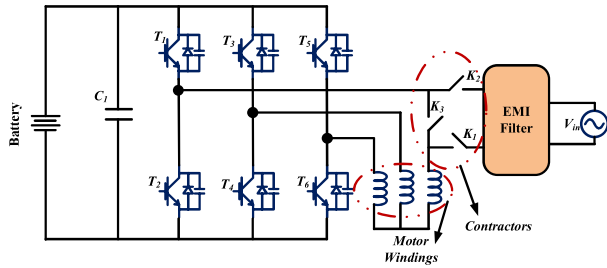
**FIGURE 23.** Integrated EV charger utilizing motor inverter and delta connected motor windings with an additional diode bridge rectifier.



**FIGURE 24.** Integrated EV charger accessing neutral points of motor windings in a two-wheel drive.

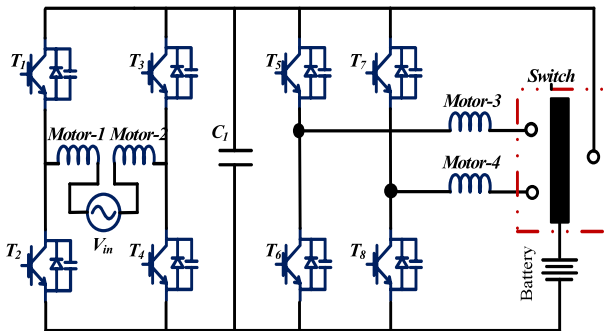
charger is for single-phase charging, where the ac supply is connected to the two neutral points of the motor windings (one neutral for each winding). In comparison to the earlier proposed solutions, this EV charger eliminates the requirement of a diode bridge rectifier and draws input line current at low THD. Another solution reported in [88] for single-phase EV charging is shown in Figure 25. The charger constitutes three contactors to select the mode of operation. For driving, contactor  $K_3$  is closed and  $K_1, K_2$  is open, while during EV charging states of the contactors are reversed. During EV charging ( $K_2$  and  $K_1$  closed) the leakage inductances of the motor windings act as inductors for the boost converter and two legs of an inverter ( $T_1$  and  $T_2$  and  $T_3$  and  $T_4$ ) are controlled by pulse width modulation (PWM). The input line current is drawn at high PF with low THD.

In [89], a four-wheel drivetrain is proposed for EV charging. Here, every wheel of EV is controlled directly by an individual three-phase inverter. In this study, the neutral point of the windings in all four motors is accessed and the ac input source is connected to the neutral points of two of these motors. By incorporating an external selector switch, the neutral points of the remaining two motor windings are

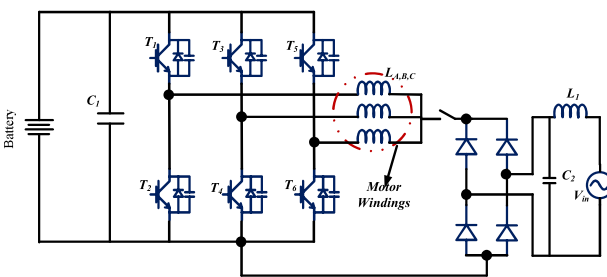


**FIGURE 25.** Integrated EV charger with motor windings and inverter working as a single-phase boost ac-dc converter.

connected to the battery during EV charging, as shown in Figure 26. Another integrated EV charger is proposed in [90], here the diode bridge rectifier and line filters are connected to the neutral point of motor winding via a mechanical switch, shown in Figure 27. After rectification, the three-phase inverter and the motor windings act as an interleaved boost converter. Since all the motor windings are utilized together, the current stress at the active switches is low.



**FIGURE 26.** Integrated EV charger accessing the neutral points of motor windings in a four-wheel drive.

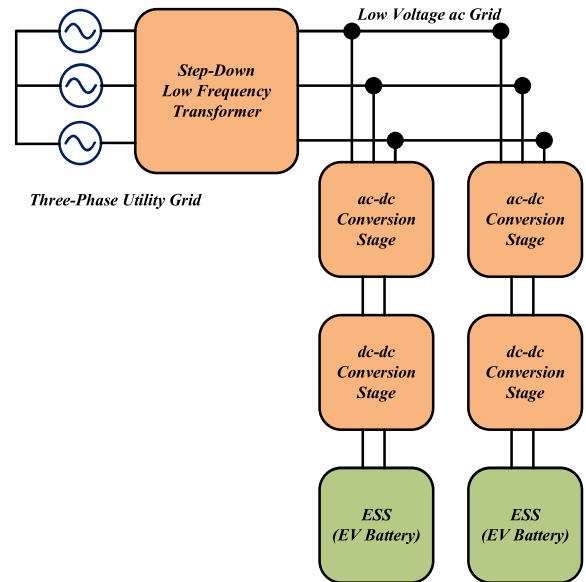


**FIGURE 27.** Integrated EV charger incorporating motor windings as three-phase boost dc-dc converter.

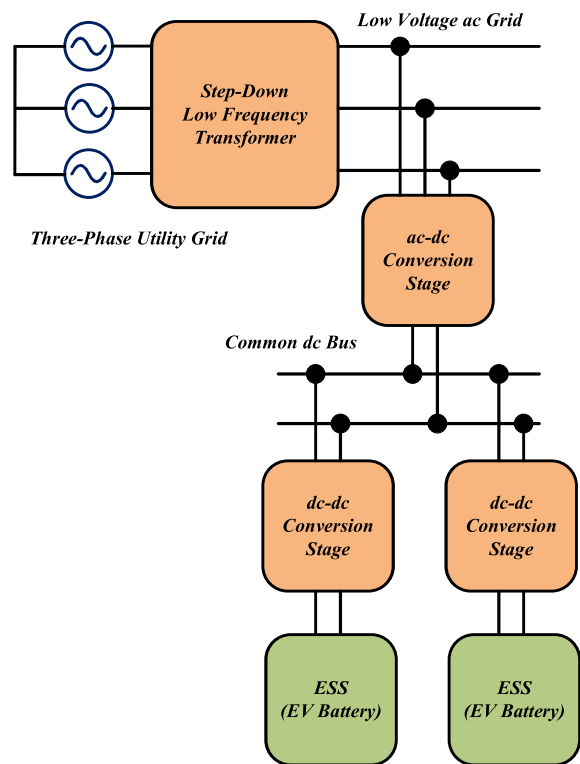
Since accessing the midpoints of motor windings is a tedious task and requires a specially designed electric machine, the aforementioned solutions still require reliability enhancements and tests before their widespread adoption and deployment.

**E. OFF-BOARD EV CHARGERS**

For fast high power EV charging, on-board EV chargers are not feasible due to their increased component cost, size, weight, and volume. As an alternative solution for fast charging, the chargers are located outside the EV and are not an



(a)



(b)

**FIGURE 28.** Off-board EV charger configurations with common (a) ac link, and (b) dc link.

integral part of an EV. In off-board charging stations, each charging unit shares either a common ac link or a common dc link, shown in Figure 28. The size of off-board EV chargers is reduced by incorporating high-frequency transformers instead of low-frequency transformers that are bulky, shown in Figure 29. The high-frequency transformer is utilized as a

TABLE 5. Specifications of off-board EV chargers.

Manufacturer	ABB	Tritium	PHIHONG	TESLA	EVTEC	ABB
Model	Tera 53	Veefil-RT	Integrated Type	Supercharger	espresso&charge	Terra HP
Power	50 kW	50 kW	120 kW	135 kW	150 kW	350 kW
Supported Protocols	CCS Type-1 CHAdeMO- 1.0	CCS Type 1&2 CHAdeMO- 1.0	GB/T	Supercharger	SAE Combo-1 CHAdeMO 1.0	SAE Combo-1 CHAdeMO 1.2
Input Voltage	480 Vac	380-480 Vac 600-900 Vac	380 Vac ± 15% 480 Vac ± 15%	380-480 Vac	400 Vac ± 10%	400 Vac ± 10%
Output Voltage	200-500 V 50-500 V	200-500 V 50-500 V	200-750 V	50-410 V	170-500 V	150-920 V
Output Current	120 A	125 A	240 A	330 A	300 A	375 A
Volume/Power (L/kW)	15.16	9.90	4.92	7.75	10.54	5.41
Weight/Power (K/kW)	8.0	3.3	2.0	4.44	2.66	3.82

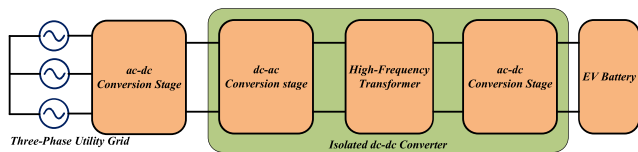


FIGURE 29. Off-board EV charger with solid-state transformer.

solid-state transformer (SST) for the dc-dc conversion stage of the EV charger.

Tesla EV charger is based on this configuration and constitutes 12 paralleled modules [91]. Table 5 summarizes specifications of various commercially available EV chargers based on the aforementioned configuration [14], [91].

The standardized protocols have been developed for off-board EV chargers by the governing bodies that are summarized in Table 6. The IEC 62196-3 standard [92] defines four EV coupler configurations for charging; (a) configuration-AA, which is proposed and implemented by CHAdeMO association; (b) configuration-BB, commonly known as GB/T and used in China only; (c) configuration-EE, Type-1 combined charging system (CCS) used by North America; and (d) configuration FF, Type-2 CCS adopted by Europe and Australia. There is a patented configuration developed by Tesla and is used exclusively for Tesla EVs. The ratings of charger and cables decide the limits on the

power to be delivered to the EV in addition to the charge acceptance ability of ESS. Currently, CHAdeMO supports the highest power capacity, confer Table 6. For fast charging, cables with large diameters are needed to avoid overloading and heating, the approximate weight of the charging cable is 9 kg for a 50 kW charger [93]. In [94], a solution is proposed to reduce the size and weight of the charger cable without affecting the power level. Authors have suggested increasing the voltage limit at which the power is transferred, it reduces the charging current, and correspondingly the diameter, size, and weight are also reduced. Cable liquid cooling is another solution that effectively reduces the thermal stress of the EV charging cable and thus the target of low weight cable is achieved. The off-board EV charging stations are categorized as the ac-connected chargers and dc-connected chargers based on the common ac link and dc link, respectively, shown in Figure 28. The ac-connected chargers have a step low-frequency transformer between the utility and a common three-phase ac link operating at 250–480 V line-to-line RMS voltage. The common ac link powers each charger at the station, and each charger has a separate ac-dc power conversion stage for controlled charging. This approach increases the power conversion stages between the utility and the dc link.

Moreover, the overall complexity and the cost of the charger are increased due to the higher number of power conversion stages. The advantages of adopting the ac link base

TABLE 6. Standards for off-board dc-fast EV chargers.

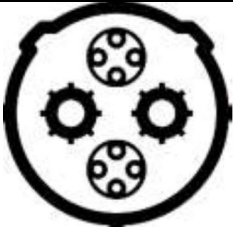
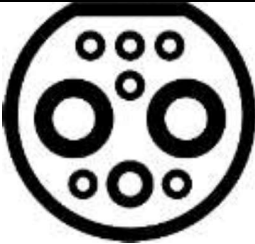



Standard	CHAdeMO IEEE 2030.1.1 IEC 62196-3 (Configuration AA)	GB/T GB/T 20234.3 IEC 2196-3 (Configuration BB)	CCS Type 1 SAE J1772 IEC 62196-3 (Configuration EE)	CCS Type 2 IEC 62196-3 (Configuration FF)	Tesla
Coupler Inlet					
Maximum Voltage	1000 V	1000 V	600 V	1000 V	410 V
Maximum Current	400 A	250 A	200 A	200 A	330 A
Available Power	400 kW	120 kW	150 kW	175 kW	135 kW

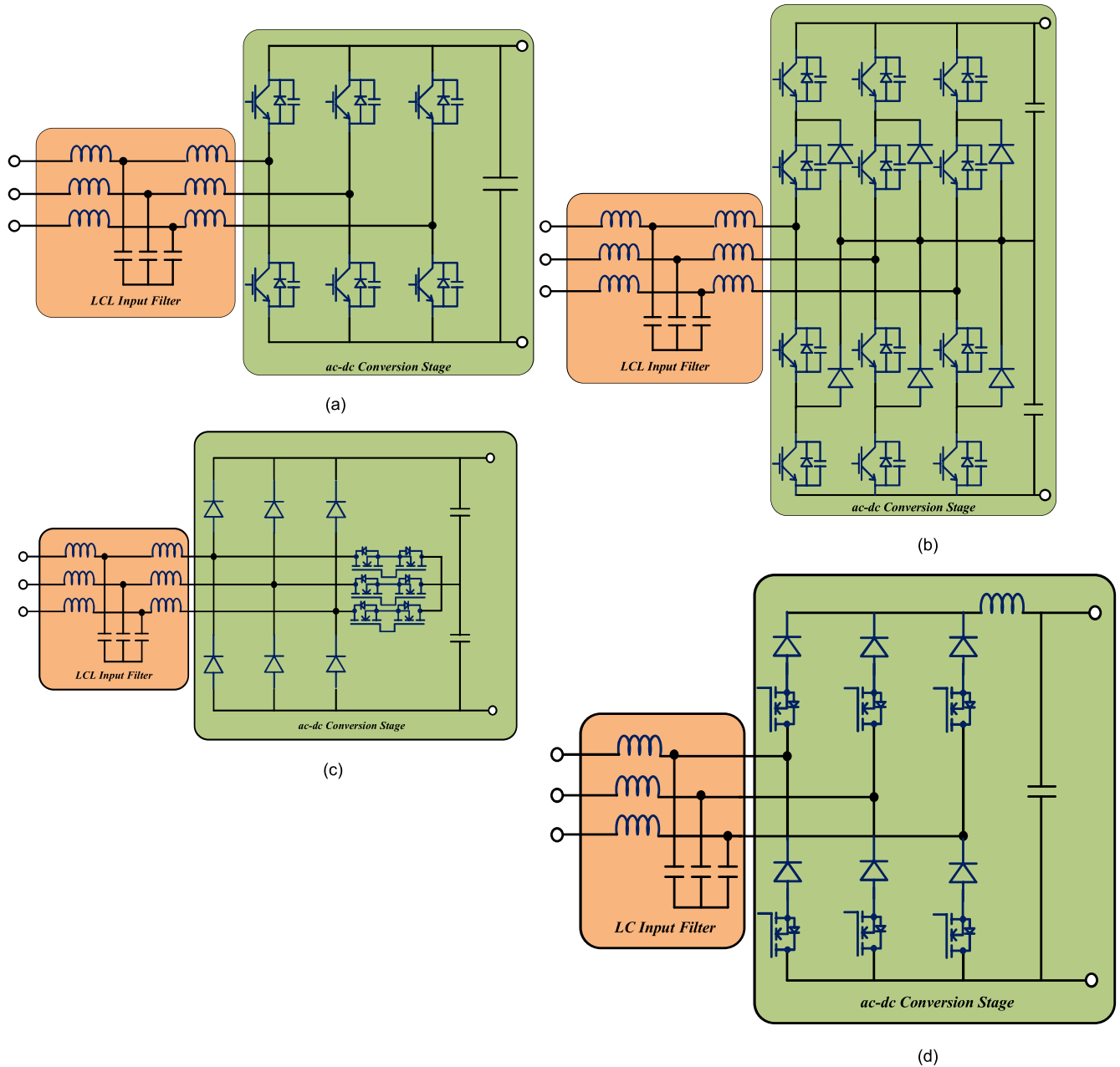
TABLE 7. Comparison of front-end ac-dc converters.

Converter configuration	Switches		THD (%)	PF Range
	Active	Passive		
Three-phase PWM converter	6	0	Low	Wide
NPC Converter	12	6	< 1	Wide
Vienna Converter	6	6	< 1	Limited
Three-phase buck converter	6	6	Low	Limited

EV charging station include the availability and maturity in the ac-dc and dc-ac power conversion technology, availability of the ac protective devices, and switchgear [95]–[98]. For the dc-connected chargers, a central front-end ac-dc converter rectifies grid power and feeds to dc link (confer Figure 28). Due to the presence of a common dc link, distributed energy resources (DER) and renewable energy resources (RES) can be interfaced easily in an efficient way. The central front-end constitutes a low-frequency transformer followed by an ac-dc conversion stage or an SST (confer Figure 28). The voltage at the dc link is 1000 V to accommodate the wide EV battery range (400-800 V). Each charger is interfaced between the dc link and a dc-dc converter for EV charging and the need for an individual ac-dc converter is elevated. Compared to ac-connected chargers, dc-connected chargers have higher efficiency due to the reduced number of power conversion stages. The advantages of the dc-connected charger include load diversification resulting from varying EV battery capacities; the absence of reactive power in the dc systems, and the opportunity of utilizing partial power converters to interface dc link and the [99]–[102]. The partial power converters

process only a portion of power that is delivered to EV and thus cost and ratings of the converter are reduced while efficiency is increased. Despite the aforementioned advantages, the hurdles in the dc-connected chargers are the undeveloped technology of adequate dc protection and metering system [103]. Also, there is a lack of established standards for protection in the dc-connected chargers due to complex grounding configuration, fault type, component specification, system topology [104]. For bidirectional chargers, this issue is more pronounced because they are more sensitive to disturbances and becomes unstable in absence of fast fault clearance. In [105], [106], protection strategies are presented base on coordination between different protective devices and loop-type, respectively. The commonly used ac-dc converters at the front-end are shown in Figure 30 and their specifications are summarized in Table 7. These converters are unidirectional or bidirectional in nature and incorporate input line filters for power conditioning [107]–[112].

The dc-dc converters at the latter stage may be isolated or non-isolated, depending on the presence of a low-frequency transformer in the front-stage. If isolation is not provided



**FIGURE 30.** Configurations of ac-dc front-end converters (a) three-phase PWM rectifier, (b) neutral point clamp rectifier, (c) vienna rectifier, and (d) three-phase buck.

at the front-end then non-isolated dc-dc converters are utilized, else the isolated dc-dc converters with a high-frequency transformer are utilized. Figure 31 and Figure 32, show non-isolated and isolated converters, respectively, for controlled charging of EV and their comparison are summarized in Table 8 [113]–[151].

**IX. IMPACT OF EV CHARGERS ON UTILITY**

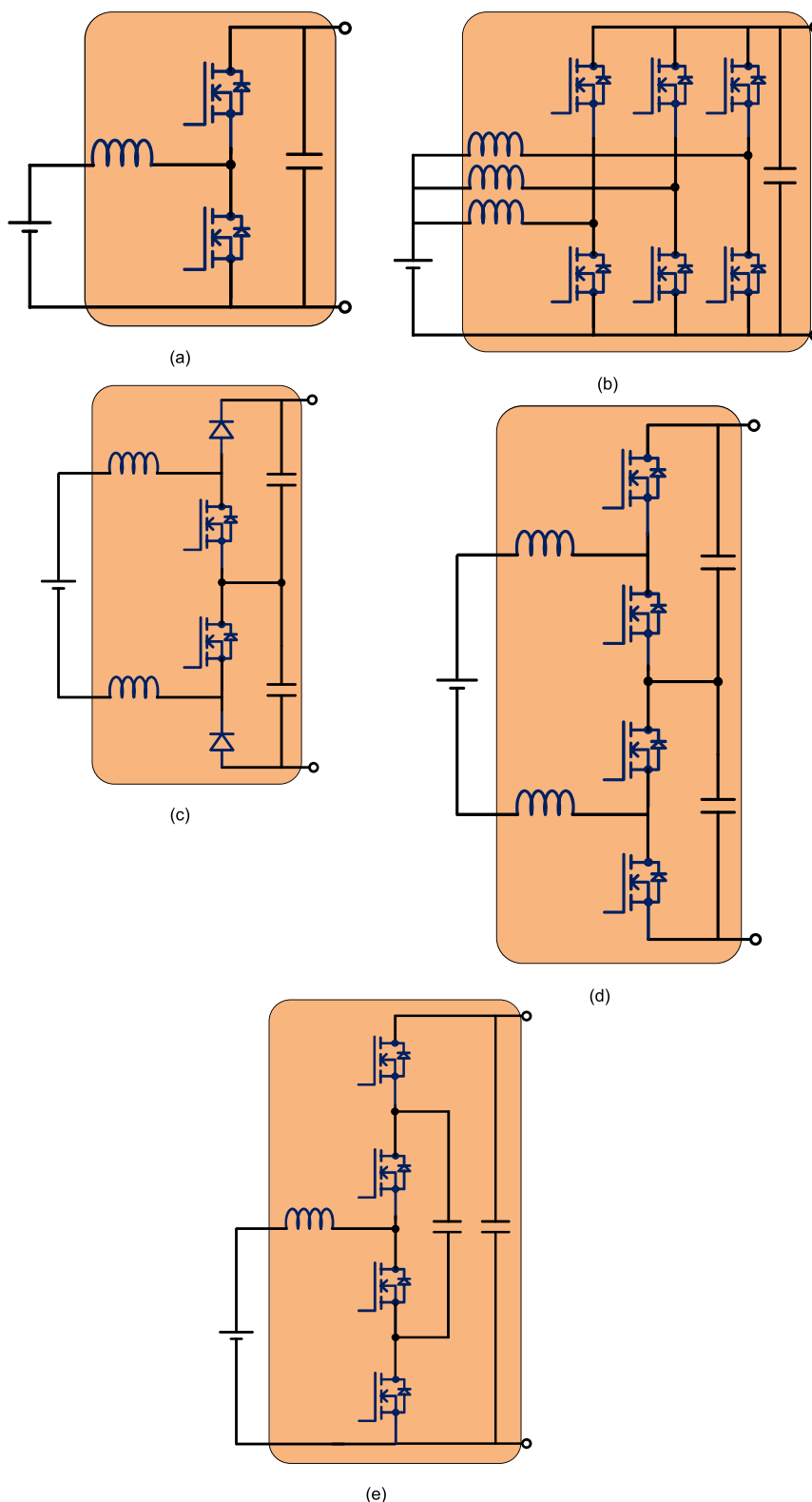
The increased deployment of EV chargers increases the load on utility. For poorly maintained utility, this issue is more pronounced. This section explores the impact of EV chargers

on various parts of the utility grid and the initiatives are discussed to reduce them.

**A. IMPACT OF RES**

Incorporating RES in the utility grid is one of the challenges due to their intermittency. The evolution of power electronics-based converters and high-density ESS have elevated the issues of intermittency and hurdles in interfacing the EV chargers. A solution to reduce the dispatchability of wind energy resources is discussed in [152]. The idea is to control the supply and demand balance of utility during EV charging

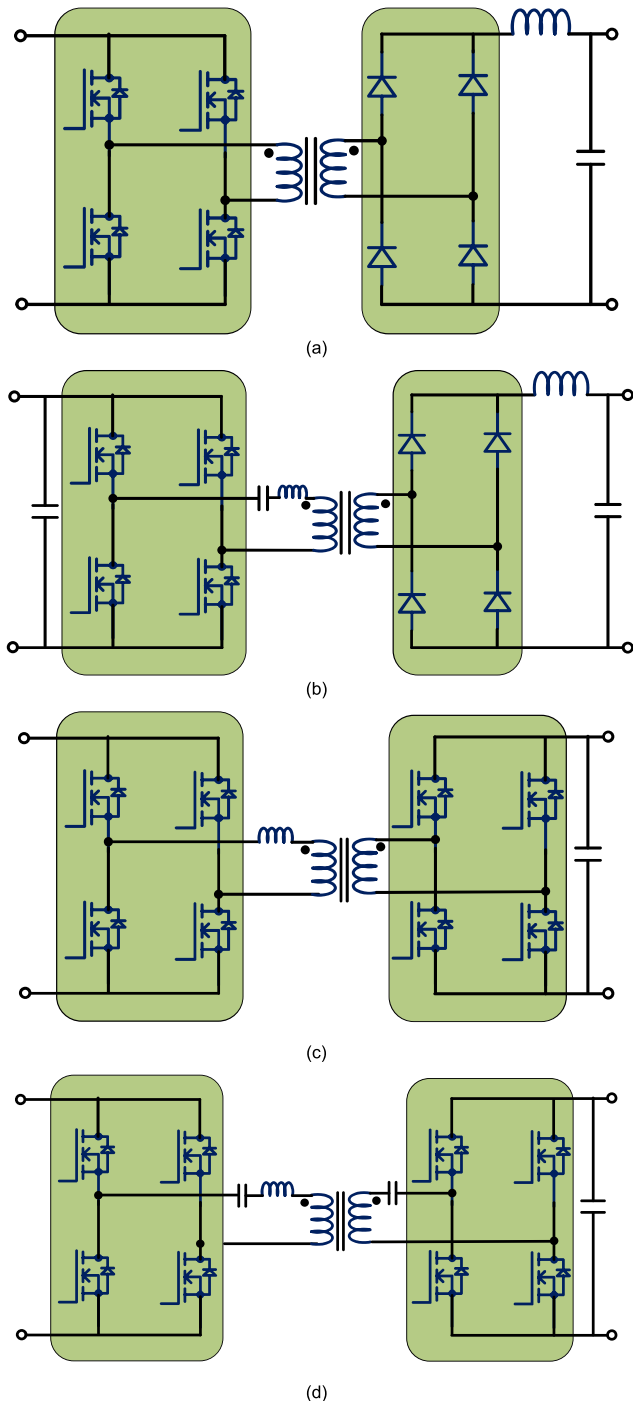




**FIGURE 31.** Nonisolated dc-dc converters (a) boost converter, (b) interleaved boost converter (c) three-level boost converter (unidirectional) (d) three-level boost converter (bidirectional), and (e) three-level flying capacitor converter.

and discharging. A study in [153] suggested maintaining constant power at the feeder that feeds EV chargers and RES. In [154], an islanded grid operation is discussed for

EV charging and a case study confirmed its effectiveness with the integration of RES. Study in [155]–[157] has successfully shown the incorporation of solar energy for EV



**FIGURE 32.** Isolated dc-dc converters (a) phase shift full-bridge converter, (b) LLC converter, (c) dual active bridge converter, and (d) CLLC converter.

charging. A detailed analysis is also presented to demonstrate the design of solar based EV charging station. The aforementioned studies show that the incorporation of RES in the utility grid enhances the grid in terms of power quality without any negative impact on it.

**B. IMPACT ON GRID STABILITY**

The EV load on the grid may raise the problems of stability in grid utility. Many distribution systems work on the verge of

instability even without the EV load, thus stability analysis is a must before connecting EV chargers as load. Stability analysis on IEEE 3-bus test system is performed for determining the stability of the grid, with and without the EV charger load [158]. The study confirmed that the EV charger load reduces the stability of the grid. In another study, the EV chargers were modeled as a constant power and a constant impedance load for the stability analysis and the results show that the constant power model of the EV charger lowers the grid stability [159], [160]. The incorporation of EV chargers in V2G mode enhances the grid stability and even the owners of EVs are able to earn during peak load periods on the grid [161]–[163].

**C. IMPACT ON SUPPLY-DEMAND BALANCE OF GRID**

A study in the city of Australia was carried out to evaluate the effect of uncontrolled EV charging. For this, all EVs in the city were considered and results from the study proved that uncontrolled EV charging increases the load on the grid and this can lead to total blackout if uncontrolled charging is carried out during peak load periods [164], [165]. Thus, the idea of coordinated charging was proposed to avoid blackouts during peak load periods on the grid. Another study performed in the city of the United Kingdom showed that increased penetration of EV charging load by 10% caused an 18% hike in the demand from utility grid [166], [167]. To meet the supply-demand balance it is necessary to integrate the RES in the charging station and utilize the smart charging techniques that include coordinated charging [168]–[172].

**D. IMPACT ON GRID ASSETS**

The main grid components that are affected by EV load, include transformers, transmission lines, and switchgear protective devices. These components deteriorate their life due to thermal overloading [173], [174]. A study in [175] based on EV chargers installed in the parking area, showed that there is a need to install new transformers to cope with the required power demand without exceeding the thermal limit and reducing the life of transformers. Another study performed in [176] with different levels of EV penetration shows the trend of system overloading. This study helps decide the EV charger locations and further modifications in the utility system. The study performed in [177] shows that the Ontario grid is adequate to absorb the EV load penetration till the end of 2025 without any modifications.

EV load penetration significantly reduces the performance of the transformer and when a fleet of EVs is charged at night then the oil-cooled transformers are highly affected and degraded since transformers are loaded more than their specified average load [178], [179]. In [180] a study performed shows that excessive overloading due to EV charger load leads to insulation failure in the transformer, however, a controlled EV charging may even derate it [181]. Thus, there is a need for reinforcement in the present grid structure and research is required to incorporate the smart charging with

TABLE 8. Comparison of dc-dc converters.

	Converter	Switches		Advantages	Disadvantages
		Active	Passive		
Non-Isolated	Boost converter	2	0	Simple control	Limited voltage & current capability
	Interleaved boost converter	6	0	Simple control, modular, high voltage, and current capability	Limited voltage capability
	Three-level boost converter	4	0	Small charging current ripples	Non-modular
	Flying capacitor converter	4	0	Modular & Stable operation	Limited protection
Isolated	Phase shifted full-bridge	4	4	Simple control,	Low efficiency
	LLC converter	4	4	Soft switching, high PF	Low efficiency, complex control
	Dual active bridge converter	8	0	Wide output voltage range	Soft switching not possible, low efficiency
	CLLC converter	8	0	High PF	Complex control

the V2G facility such that the negative impact of charging on grid assets may be reduced or elevated [182], [183].

**E. IMPACT ON GRID VOLTAGE**

This section deals with how the grid voltage is affected as the penetration of EV chargers is increased. A study performed in [184] shows 12.7%-43.3% voltage deviation as the penetration of EV chargers is increased from 20% to 80%. Penetration of single-phase EV chargers also leads to poor PF and unbalancing in the grid. 1%-2% penetration of EV chargers shows the voltage sag [185]. In [186], a study is performed with 50% to 100% penetration of EV chargers and the results show that even a level-1 charging is capable to cause voltage deviations from the normal specified values. Thus, the EV charger penetration limits must be decided beforehand and these must be followed to avoid voltage problems.

**F. IMPACT ON GRID CURRENT HARMONICS**

The non-linear power electronics involved in the EV chargers are responsible for injecting the current harmonics into the grid. The amount of THD in the line current drawn by the EV charger depends directly on the circuit topology of the charger [187]. Usually, odd harmonics dominate and contribute to THD in the input line current. Usually, EV chargers have input line filters before the front-end rectifier to smooth out the input current so that the harmonics injected in current are reduced [188]. To reduce the current harmonics, EV chargers involve high-frequency PWM or modified PWM techniques, also matrix converters are involved for multi-phase EV chargers. These high-frequency converters reduce THD in current but increase the charger circuit complexity [189], [190]. Active power conditioning circuits along with the active filters are used for harmonic reduction. The increased harmonics content in input line current directly affects the PF which in turn increases the RMS value of line current and deteriorates the different assets of the grid

(transformer). Thus, the modern EV chargers deployed at the charging station draw current with low THD and high PF [191], [192].

**G. IMPACT ON GRID LOSSES**

The losses in the grid due to EV chargers are because of increased RMS current which in turn increases the  $I^2R$  losses, where  $I$  is the RMS value of current drawn and  $R$  is the equivalent resistance of the grid [165]–[167]. The increased losses in the grid are also responsible for deteriorating the life span of grid components. These losses are increased by 40% during the off-peak charging period, while 62% during the peak period. To reduce these losses the EV charger must draw the input line current with lower harmonic content and at a high power factor.

**H. INITIATIVES TO REDUCE GRID IMPACT**

To reduce the negative impact of EV chargers, various measures are proposed and are discussed in the literature. The EV chargers do not overload the grid if it is connected in a well-planned coordinated way [193]. The losses in the grid can be minimized by incorporating the smart metering system to maintain the supply and demand balance [194], [195]. For reduction of current harmonics in the line current drawn by the EV chargers, the proposed methods include the deployment of EV chargers with input line filters for power conditioning, adopting advanced PWM techniques for reducing lower order harmonics, and avoiding common mode current to reduce electromagnetic interference (EMI) [195]. Usage of RES also reduces the negative impacts of EV chargers on the grid.

**X. INTERNATIONAL STANDARDS FOR EV CHARGERS**

The international standards are developed by a team of experts and are adopted universally. For deployment of EV chargers successfully various international standards are

developed and published. These are well developed to fulfill the safety issues, reliability, and interoperability issues of the EV industry [196]. Various industries that utilize these standards include EV manufacturers, ESS manufacturers, utility companies, EV charger manufacturers, code officials, EV charger safety equipment manufacturers, and insurance companies.

Different EV charging standards [196]–[204] in the literature that is utilized are discussed as follows-

#### A. SOCIETY FOR AUTOMOBILE ENGINEERS (SAE)

- J1772: EV conductive connector/charging method.
- J2894: Issues of power quality.
- J2836/2847/2931: Communication purposes.
- J1773: Inductive coupled charging.
- J2293: For energy transfer systems to find the requirements for EVs.

#### B. NATIONAL FIRE PROTECTION ASSOCIATION (NFPA)

- NFPA 70: Safety management.
- NEC 625/626: Charging systems for EVs.
- NFPA 70E: For safety.
- NFPA 70B: Maintenance of electrical equipment.

#### C. INSTITUTE OF ELECTRICAL AND ELECTRONICS ENGINEERS (IEEE)

- IEEE 2030.1.1: Quick DC charging for EVs.
- IEEE P2690: Charging network management, Vehicle authorization.
- IEEE P1809: Electric transportation guide.
- IEEE 1547: Interconnecting electric system with distributed resources/Tie Grid.
- IEEE 1901: Provide data rate while vehicles are charged overnight.
- IEEE P2030: Interoperability of smart grid.
- IEEE 519-2014: Power quality standards.

#### D. INTERNATIONAL ELECTROMECHANICAL COMMISSION (IEC)

- IEC-1000-3-6: Issues of power quality.
- IEC TC 69: Regarding infrastructure of charging and safety requirements.
- IEC TC 64: Electrical installation, electric shock protection.
- IEC TC 21: Regarding battery management.

#### E. UNDERWRITERS LABORATORIES (UL) INC

- UL 2231: Safety Purposes.
- UL 2594/2251,2201: EVSE.

#### F. INTERNATIONAL ORGANIZATION FOR STANDARDIZATION

- ISO 6469-1:2009: Used for on-board rechargeable energy storage systems.
- ISO/CD 6469-3.3: Safety specifications.

#### G. JAPAN ELECTRIC VEHICLE ASSOCIATION

- JEVS C601: EVs charging plugs.
- JEVS D701: Batteries.
- JEVS G101-109: Fast Charging.

#### H. ISOLATION AND TECHNICAL SAFETY STANDARDS

- SAE J-2929: This standard is related to the safety of the propulsion battery system.
- SAE J-2910: This standard deals with the electrical safety of buses and test for hybrid electric trucks.
- SAE J-2344: Defines rules for EV's safety.
- SAE J-2464: Standard defines the safety rules for recharge energy storage systems (RESS).
- ISO 6469-1:2009 (IEC): Standard is related to electrically road vehicles, on-board RESS, inside and outside protection of a person.
- ISO 6469-2:2009 (IEC): Safe operation of EVs, protect against inside failure.
- ISO 6469-2:2001 (IEC): Electrical hazard protection.
- IEC TC 69/64: EVs infrastructure safety, electrical installation, electric shock protection.
- NFPA 70/70 E: Standards related to workplace safety, charging system safety, branch circuit protection.
- UL 2202: Standard is related to the protection of the charging system.
- UL 2231: This standard deals with the protection of the supply circuits.
- UL 225a: It provides rules of protection regarding couplers, plugs, and receptacles.
- DIN V VDE 0510-11: Provides safety regulations for battery installation and secondary batteries.

#### XI. NEAR TO FUTURE ADVANCEMENTS IN EV TECHNOLOGY

Since EVs are supposed to take the place of conventional vehicles, the development in technology is growing every day. At present, there are lots of EV charger manufacturers and these are being even deployed in most of the developed and developing countries. However, research is going on towards further improvement and currently, researchers are more focused towards:

- 1) Development of robust and cost-effective off-board and on-board EV chargers with improved power quality at grid and EV side.
- 2) Development of high-voltage (1100 V DC) off-board chargers to reduce the overall footprint of the charging station.
- 3) Development of on-board charger with the minimum requirement of additional PEI.
- 4) New and optimized design of power pads for efficient WPT.
- 5) Optimized planning of EV charging such that the grid stability is improved and the EV owner can earn by selling its extra energy either to utility (V2G operation) or to other EV owners (V2V operation).

- 6) Usage of wide band-gap power semiconductor devices such as silicon carbide (SiC) and gallium nitride (GaN). Key features of these devices are high efficiency, high power density, and low thermal stress.
- 7) Development of ESS with high energy density, low cost, volume, and weight.

## XII. CONCLUSION

This paper describes the need for EVs in the transportation sector and provides a comprehensive review of different components of EV technology. EVSE is mentioned along with the different ESS for EVs. The detailed classification of EVs is mentioned that include BEVs, PHEVs, and BEVs. Different on-board and off-board chargers are discussed with low-/high-frequency transformers in the front-stage and end-stage, respectively. It is shown that the on-board chargers are integrated with EVs and are usually low power chargers that take a long time to fully charge the EVs. While off-board chargers are high-power chargers that are deployed outside the EVs and take less than an hour to charge the EV. The different charging standards, CHAdeMO, GB/T, and CCS are discussed along with their specifications and connectors. The concept of IPT for charging the EV while moving is explained. Furthermore, the negative impacts of EV chargers on the grid are mentioned along with the remedial solutions. Different international standards for EV technology are mentioned that need to be followed universally for the successful penetration of EVs in the transportation sector. Finally, the future trends and research areas have been highlighted that need to be worked on.

## REFERENCES

- [1] M. R. Khalid, M. S. Alam, A. Sarwar, and M. S. J. Asghar, "A comprehensive review on electric vehicles charging infrastructures and their impacts on power-quality of the utility grid," *eTransportation*, vol. 1, Aug. 2019, Art. no. 100006.
- [2] *Annual Energy Outlook 2009, With Projections to 2030*, U.S. Energy Inf. Admin., Washington, DC, USA, p. 221, Mar. 2009, vol. 383.
- [3] J. M. Grütter and K.-J. Kim, "E-mobility options ADB developing member countries," ADB Sustain. Develop. Work. Paper Ser., Mar. 2019, pp. 1–10, vol. 60.
- [4] *Global EV Outlook*, Int. Energy Agency, 2020, pp. 8–25.
- [5] IEA, Paris, France. (2020). *Transport Sector CO<sub>2</sub> Emissions by Mode in the Sustainable Development Scenario, 2000–2030*. Accessed: May 30, 2021. [Online]. Available: <https://www.iea.org/data-and-statistics/charts/transport-sector-co2-emissions-by-mode-in-the-sustainable-development-scenario-2000-2030>
- [6] M. Ehsani, Y. Gao, and A. Emadi, *Modern Electric, Hybrid Electric, and Fuel Cell Vehicles*, 2nd ed. Boca Raton, FL, USA: CRC Press, 2010.
- [7] *Adoption of the Paris Agreement*, United Nations, New York, NY, USA, Dec. 2015.
- [8] B. Nykvist and M. Nilsson, "Rapidly falling costs of battery packs for electric vehicles," *Nature Climate Change*, vol. 5, no. 4, p. 329, Apr. 2015.
- [9] Z. P. Cano, D. Banham, S. Ye, A. Hintennach, J. Lu, M. Fowler, and Z. Chen, "Batteries and fuel cells for emerging electric vehicle markets," *Nature Energy*, vol. 3, no. 4, p. 279, 2018.
- [10] S. Ahmed et al., "Enabling fast charging—A battery technology gap assessment," *J. Power Sources*, vol. 367, pp. 250–262, Nov. 2017.
- [11] M. Keyser et al., "Enabling fast charging—battery thermal considerations," *J. Power Sources*, vol. 367, pp. 228–236, Nov. 2017.
- [12] J. Beretta, *Automotive Electricity*. New York, NY, USA: Wiley, 2010.
- [13] C. C. Chan and K. T. Chau, "An overview of power electronics in electric vehicles," *IEEE Trans. Ind. Electron.*, vol. 44, no. 1, pp. 3–13, Feb. 1997.
- [14] H. Tu, H. Feng, S. Srdic, and S. Lukic, "Extreme fast charging of electric vehicles: A technology overview," *IEEE Trans. Transport. Electrific.*, vol. 5, no. 4, pp. 861–878, Dec. 2019, doi: [10.1109/TTE.2019.2958709](https://doi.org/10.1109/TTE.2019.2958709).
- [15] M. Yilmaz and P. T. Krein, "Review of battery charger topologies, charging power levels, and infrastructure for plug-in electric and hybrid vehicles," *IEEE Trans. Power Electron.*, vol. 28, no. 5, pp. 2151–2169, May 2013, doi: [10.1109/TPEL.2012.2212917](https://doi.org/10.1109/TPEL.2012.2212917).
- [16] *Electric Vehicle Charging*, Netherlands Enterprise Agency, Jan. 2019, pp. 4–10.
- [17] *Vehicle Technologies Program*, U.S. Dept. Energy, Washington, DC, USA, Oct. 2011.
- [18] M. Ehsani, Y. Gao, S. E. Gay, and A. Emadi, *Modern Electric, Hybrid Electric, and Fuel Cell Vehicles*. Boca Raton, FL, USA: CRC Press, 2005.
- [19] A. Emadi, M. Ehsani, and J. M. Miller, *Vehicular Electric Power Systems: Land, Sea, Air, and Space Vehicles*. New York, NY, USA: Marcel Dekker, 2003.
- [20] J. Larminie and J. Lowry, *Electric Vehicle Technology Explained*. New York, NY, USA: Wiley, 2003.
- [21] A. Y. Saber and G. K. Venayagamoorthy, "One million plug-in electric vehicles on the road by 2015," in *Proc. 12th Int. IEEE Conf. Intell. Transp. Syst.*, Oct. 2009, pp. 141–147.
- [22] S. Dusmez, A. Cook, and A. Khaligh, "Comprehensive analysis of high quality power converters for level 3 off-board chargers," in *Proc. IEEE Vehicle Power Propuls. Conf.*, Sep. 2011, pp. 1–10.
- [23] S. Vazquez, S. M. Lukic, E. Galvan, L. G. Franquelo, and J. M. Carrasco, "Energy storage systems for transport and grid applications," *IEEE Trans. Ind. Electron.*, vol. 57, no. 12, pp. 3881–3895, Dec. 2010.
- [24] J. A. Carcone, "Performance of lithium-ion battery systems," in *Proc. WESCON*, Sep. 1994, pp. 242–248.
- [25] G. M. Ehrlich, R. M. Hellen, and T. B. Reddy, "Prismatic cell lithium-ion battery using lithium manganese oxide," in *Proc. 12th Annu. Battery Conf. Appl. Adv.*, Jan. 1997, pp. 121–125.
- [26] *Datasheet*, GAIA, India. Accessed: 2021.
- [27] A. Burke, "Performance testing of lithium-ion batteries of various chemistries for EV and PHEV applications," presented at the ZEV Symp., Sep. 2009.
- [28] *Datasheet*, Kokam, Seoul, South Korea, 2021.
- [29] *Datasheet*, A123 Syst., Livonia, MI, USA, 2021.
- [30] *Datasheet*, Altairmano, Cody, WY, USA, 2021.
- [31] *Datasheet*, EIG Battery, Cheonan, South Korea.
- [32] *Datasheet*, Thunder Sky/Winston Battery, Fujian, China.
- [33] *Datasheet*, BYD, Shenzhen, China, 2021.
- [34] *Datasheet*, RFE, Tokyo, Japan.
- [35] *Datasheet*, Lishen, Tianjin, China, 2021.
- [36] A. Corley, "Nissan's all-electric leaf doesn't stint on performance," *IEEE Spectr. Magazine*, Apr. 2010.
- [37] C. H. Lin, C. Y. Hsieh, and K. H. Chen, "A Li-ion battery charger with smooth control circuit and built-in resistance compensator for achieving stable and fast charging," *IEEE Trans. Circuits Syst. I, Reg. Papers*, vol. 57, no. 2, pp. 506–517, Feb. 2010.
- [38] S. Li, C. Zhang, and S. Xie, "Research on fast charge method for lead-acid electric vehicle batteries," in *Proc. Int. Workshop Intell. Syst. Appl.*, May 2009, pp. 1–5.
- [39] L.-R. Chen, R.-C. Hsu, C.-S. Liu, W.-Z. Yen, N.-Y. Chu, and Y.-L. Lin, "A variable frequency pulse charge for Li-ion battery," in *Proc. IEEE Int. Symp. Ind. Electron. (ISIE)*, vol. 3, Jun. 2005, pp. 995–1000.
- [40] J. Chen, M.-K. Nguyen, Z. Yao, C. Wang, L. Gao, and G. Hu, "DC-DC converters for transportation electrification," *IEEE Electrific. Mag.*, vol. 9, no. 2, pp. 10–22, Jun. 2021.
- [41] B. Singh, B. N. Singh, A. Chandra, K. Al-Haddad, A. Pandey, and D. P. Kothari, "A review of three-phase improved power quality AC-DC converters," *IEEE Trans. Ind. Electron.*, vol. 51, no. 3, pp. 641–660, Jun. 2004.
- [42] M. A. Fasugba and P. T. Krein, "Gaining vehicle-to-grid benefits with unidirectional electric and plug-in hybrid vehicle chargers," in *Proc. IEEE Veh. Power Propuls. Conf.*, Sep. 2011, pp. 1–6.
- [43] K. Drobnic, G. Grandi, M. Hammami, R. Mandrioli, M. Ricco, A. Viatkin, and M. Vujacic, "An output ripple-free fast charger for electric vehicles based on grid-tied modular three-phase interleaved converters," *IEEE Trans. Ind. Appl.*, vol. 55, no. 6, pp. 6102–6114, Nov. 2019, doi: [10.1109/TIA.2019.2934082](https://doi.org/10.1109/TIA.2019.2934082).
- [44] M. Grenier, M. G. H. Aghdam, and T. Thiringer, "Design of on-board charger for plug-in hybrid electric vehicles," in *Proc. Power Electron., Mach. Drives*, 2010, pp. 1–6.

- [45] S. Haghbin, K. Khan, S. Lundmark, M. Alakula, O. Carlson, M. Leks, and O. Wallmark, "Integrated chargers for EV's and PHEV's: Examples and new solutions," in *Proc. 19th Int. Conf. Electr. Mach. (ICEM)*, Sep. 2010, pp. 1–6.
- [46] E. Bryan, M. Sid-Ahmed, and N. C. Kar, "A comparative study of power supply architectures in wireless EV charging systems," *IEEE Trans. Power Electron.*, vol. 30, no. 11, pp. 64–72, Jun. 2015.
- [47] W. Chen, C. Liu, C. Lee, and Z. Shan, "Cost-effectiveness comparison of coupler designs of wireless power transfer for electric vehicle dynamic charging," *Energies*, vol. 9, no. 11, p. 906, Nov. 2016.
- [48] V.-B. Vu, D.-H. Tran, and W. Choi, "Implementation of the constant current and constant voltage charge of inductive power transfer systems with the double-sided LCC compensation topology for electric vehicle battery charge applications," *IEEE Trans. Power Electron.*, vol. 33, no. 9, pp. 7398–7410, Sep. 2018.
- [49] S. Lukic and Z. Pantic, "Cutting the cord: Static and dynamic inductive wireless charging of electric vehicles," *IEEE Electrific. Mag.*, vol. 1, no. 1, pp. 57–64, Sep. 2013.
- [50] S. Li, Z. Liu, H. Zhao, L. Zhu, C. Shuai, and Z. Chen, "Wireless power transfer by electric field resonance and its application in dynamic charging," *IEEE Trans. Ind. Electron.*, vol. 63, no. 10, pp. 6602–6612, Oct. 2016, doi: [10.1109/TIE.2016.2577625](https://doi.org/10.1109/TIE.2016.2577625).
- [51] B. Singh, B. N. Singh, A. Chandra, K. Al-Haddad, A. Pandey, and D. P. Kothari, "A review of single-phase improved power quality AC-DC converters," *IEEE Trans. Ind. Electron.*, vol. 50, no. 5, pp. 962–981, Oct. 2003.
- [52] M. A. Fasugba and P. T. Krein, "Cost benefits and vehicle-to-grid regulation services of unidirectional charging of electric vehicles," in *Proc. IEEE Energy Convers. Congr. Expo.*, Sep. 2011, pp. 827–834.
- [53] G. Kissel, *SAE J1772 Update for IEEE Standard 1809 Guide for Electric-Sourced Transportation Infrastructure Meeting*, Standard SAE J1772, SAE International, Sep. 2010.
- [54] M. Y. Metwly, M. S. Abdel-Majeed, A. S. Abdel-Khalik, R. A. Hamdy, M. S. Hamad, and S. Ahmed, "A review of integrated on-board EV battery chargers: Advanced topologies, recent developments and optimal selection of FSCW slot/pole combination," *IEEE Access*, vol. 8, pp. 85216–85242, 2020, doi: [10.1109/ACCESS.2020.2992741](https://doi.org/10.1109/ACCESS.2020.2992741).
- [55] T. Chen, X. Zhang, J. Wang, J. Li, C. Wu, M. Hu, and H. Bian, "A review on electric vehicle charging infrastructure development in the UK," *J. Mod. Power Syst. Clean Energy*, vol. 8, no. 2, pp. 193–205, Mar. 2020, doi: [10.35833/MPCE.2018.000374](https://doi.org/10.35833/MPCE.2018.000374).
- [56] A. Salem and M. Narimani, "A review on multiphase drives for automotive traction applications," *IEEE Trans. Transport. Electrific.*, vol. 5, no. 4, pp. 1329–1348, Dec. 2019, doi: [10.1109/TTE.2019.2956355](https://doi.org/10.1109/TTE.2019.2956355).
- [57] G.-Y. Choe, J.-S. Kim, B.-K. Lee, C.-Y. Won, and T.-W. Lee, "A bi-directional battery charger for electric vehicles using photovoltaic PCS systems," in *Proc. IEEE Vehicle Power Propuls. Conf.*, Sep. 2010, pp. 1–6.
- [58] Y. Du, S. Lukic, B. Jacobson, and A. Huang, "Review of high power isolated bi-directional DC-DC converters for PHEV/EV DC charging infrastructure," in *Proc. IEEE Energy Convers. Congr. Expo. (ECCE)*, Sep. 2011, pp. 553–560.
- [59] E. Sortomme and M. A. El-Sharkawi, "Optimal charging strategies for unidirectional vehicle-to-grid," *IEEE Trans. Smart Grid*, vol. 2, no. 1, pp. 131–138, Mar. 2011.
- [60] H. Chen, X. Wang, and A. Khaligh, "A single stage integrated bidirectional AC/DC and DC/DC converter for plug-in hybrid electric vehicles," in *Proc. IEEE Vehicle Power Propuls. Conf.*, Sep. 2011, pp. 1–6.
- [61] N. M. L. Tan, T. Abe, and H. Akagi, "Design and performance of a bidirectional isolated DC-DC converter for a battery energy storage system," *IEEE Trans. Power Electron.*, vol. 27, no. 3, pp. 1237–1248, Mar. 2012.
- [62] W. Su, H. Rahimi-Eichi, W. Zeng, and M.-Y. Chow, "A survey on the electrification of transportation in a smart grid environment," *IEEE Trans. Ind. Informat.*, vol. 8, no. 1, pp. 1–10, Feb. 2012.
- [63] M. Duvall, "Charging infrastructure update," in *Proc. Electr. Power Res. Inst. (EPRI), CPUC Electric Veh. Workshop*, Mar. 2010, pp. 35–39.
- [64] *SAE Electric Vehicle Inductive Coupling Recommended Practice*, Standard SAE 5-1773, Feb. 1995.
- [65] De-Sousa, B. Silvestre, and B. Bouchez, "A combined multiphase electric drive and fast battery charger for electric vehicles," in *Proc. IEEE Veh. Power Propuls. Conf.*, Sep. 2010, pp. 1–6.
- [66] D. P. Tuttle and R. Baldick, "The evolution of plug-in electric vehicle-grid interactions," *IEEE Trans. Smart Grid*, vol. 3, no. 1, pp. 500–505, Mar. 2012.
- [67] CHAdEMO. (2021). *What is CHAdEMO?* [Online]. Available: [http://chademo.com/01\\_What\\_is\\_CHAdEMO.html](http://chademo.com/01_What_is_CHAdEMO.html)
- [68] M. Thomason. (2021). *Plug-in Recharge*. [Online]. Available: [http://www1.eere.energy.gov/vehiclesandfuels/avta/light\\_duty/fsev/fsev\\_battery\\_chargers](http://www1.eere.energy.gov/vehiclesandfuels/avta/light_duty/fsev/fsev_battery_chargers)
- [69] S. Bae and A. Kwasinski, "Spatial and temporal model of electric vehicle charging demand," *IEEE Trans. Smart Grid*, vol. 3, no. 1, pp. 394–403, Mar. 2012.
- [70] C. Qiao and K. M. Smedley, "A topology survey of single-stage power factor corrector with a boost type input-current-shaper," *IEEE Trans. Power Electron.*, vol. 16, no. 3, pp. 360–368, May 2001.
- [71] J. P. M. Figuerido, F. L. Tofili, and B. L. A. Silva, "A review of single phase PFC topologies based on the boost converter," in *Proc. IEEE Int. Conf. Ind. Appl.*, Sao Paulo, Brazil, Nov. 2010, pp. 1–6.
- [72] F. Musavi, W. Eberle, and W. G. Dunford, "A high-performance single-phase bridgeless interleaved PFC converter for plug-in hybrid electric vehicle battery chargers," *IEEE Trans. Ind. Appl.*, vol. 47, no. 4, pp. 1833–1843, Aug. 2011.
- [73] F. Musavi, W. Eberle, and W. G. Dunford, "A phase shifted semi-bridgeless boost power factor corrected converter for plug-in hybrid electric vehicle battery chargers," in *Proc. IEEE Appl. Power Electron. Conf. Expo.*, Fort Worth, TX, USA, Mar. 2011, pp. 821–828.
- [74] D. C. Erb, O. C. Onar, and A. Khaligh, "Bi-directional charging topologies for plug-in hybrid electric vehicles," in *Proc. 25th Annu. IEEE Appl. Power Electron. Conf. Expo. (APEC)*, Feb. 2010, pp. 2066–2072.
- [75] Y. Du, S. Lukic, B. Jacobson, and A. Huang, "Review of high power isolated bi-directional DC-DC converters for PHEV/EV DC charging infrastructure," in *Proc. IEEE Energy Convers. Congr. Expo.*, Phoenix, AZ, USA, Sep. 2011, pp. 553–560.
- [76] D. Gautam, F. Musavi, M. Edington, W. Eberle, and W. G. Dunford, "An automotive on-board 3.3 kW battery charger for PHEV application," in *Proc. IEEE Vehicle Power Propuls. Conf.*, Chicago, IL, USA, Sep. 2011, pp. 1–6.
- [77] D. Gautam, F. Musavi, M. Edington, W. Eberle, and W. G. Dunford, "A zero voltage switching full-bridge DC-DC converter with capacitive output filter for a plug-in-hybrid electric vehicle battery charger," in *Proc. 27th Annu. IEEE Appl. Power Electron. Conf. Expo. (APEC)*, Orlando, FL, USA, Feb. 2012, pp. 1381–1386.
- [78] H. J. Chae, H. T. Moon, and J. Y. Lee, "On-board battery charger for PHEV without high-voltage electrolytic capacitor," *Electron. Lett.*, vol. 46, no. 25, pp. 1691–1692, Dec. 2010.
- [79] H. J. Chae, W. Y. Kim, S. Y. Yun, Y. S. Jeong, J. Y. Lee, and H. T. Moon, "3.3 kW on board charger for electric vehicles," in *Proc. Int. Conf. Power Electron.*, Shilla Jeju, South Korea, Jun. 2011, pp. 2717–2719.
- [80] J. S. Kim, G.-Y. Choe, H.-M. Jung, B.-K. Lee, Y.-J. Cho, and K.-B. Han, "Design and implementation of a high-efficiency on-board battery charger for electric vehicles with frequency control strategy," in *Proc. IEEE Veh. Power Propuls. Conf.*, Lille, France, Sep. 2010, pp. 1–6.
- [81] Y.-J. Lee, A. Khaligh, and A. Emadi, "Advanced integrated bidirectional AC/DC and DC/DC converter for plug-in hybrid electric vehicles," *IEEE Trans. Veh. Technol.*, vol. 58, no. 8, pp. 3970–3980, Oct. 2009.
- [82] D. C. Erb, O. C. Onar, and A. Khaligh, "An integrated bi-directional power electronic converter with multi-level AC-DC/DC-AC converter and non-inverted buck-boost converter for PHEVs with minimal grid level disruptions," in *Proc. IEEE Vehicle Power Propuls. Conf.*, Sep. 2010, pp. 1–6.
- [83] H. Chen, X. Wang, and A. Khaligh, "A single stage integrated bidirectional AC/DC and DC/DC converter for plug-in hybrid electric vehicles," in *Proc. IEEE Vehicle Power Propuls. Conf.*, Sep. 2011, pp. 1–6.
- [84] S. Dusmez and A. Khaligh, "A novel low cost integrated on-board charger topology for electric vehicles and plug-in hybrid electric vehicles," in *Proc. 27th Annu. IEEE Appl. Power Electron. Conf. Expo. (APEC)*, Feb. 2012, pp. 2611–2616.
- [85] S. Dusmez and A. Khaligh, "Cost effective solutions to level-3 on-board battery chargers," in *Proc. Appl. Power Electron. Conf.*, Feb. 2012, pp. 2121–2127.
- [86] G. Pellegrino, E. Armando, and P. Guglielmi, "An integral battery charger with power factor correction for electric scooter," *IEEE Trans. Power Electron.*, vol. 25, no. 3, pp. 751–759, Mar. 2010.

- [87] H.-C. Chang and C.-M. Liaw, "An integrated driving/charging switched reluctance motor drive using three-phase power module," *IEEE Trans. Ind. Electron.*, vol. 58, no. 5, pp. 1763–1775, May 2011.
- [88] A. G. C. Glendora, "Combined motor drive and battery charger system," U.S. Patent 5 341 075, Aug. 23, 1994.
- [89] S.-K. Sul and S.-J. Lee, "An integral battery charger for four-wheel drive electric vehicle," *IEEE Trans. Ind. Appl.*, vol. 31, no. 5, pp. 1096–1099, Sep./Oct. 1995.
- [90] L. Solero, "Nonconventional on-board charger for electric vehicle propulsion batteries," *IEEE Trans. Veh. Technol.*, vol. 50, no. 1, pp. 144–149, Jan. 2001.
- [91] E. Loveday. *Rare Look Inside Tesla Supercharger*. Accessed: Jul. 10, 2021. [Online]. Available: <https://insideevs.com/news/322486/rare-look-inside-tesla-supercharger/>
- [92] *Plugs, Socket-Outlets, Vehicle Connectors and Vehicle Inlets-Conductive Charging of Electric Vehicles—Part 3: Dimensional Compatibility and Interchangeability Requirements for D.C. and A.C./D.C. Pin and Contact-Tube Vehicle Couplers*, Standard IEC 62196-3:2014, Jun. 2014, p. 1.
- [93] A. Yoshida. *Chademo Quick Charger Connector With Excellent Operability*. Accessed: Nov. 15, 2019. [Online]. Available: <https://globalsei.com/technology/tr/bn84/pdf/84-05.pdf>
- [94] A. Burnham et al., "Enabling fast charging-infrastructure and economic considerations," *J. Power Sources*, vol. 367, pp. 237–249, Nov. 2017.
- [95] *Electric Vehicle Conductive Charging System—Part 1: General Requirements*, Standard IEC 61851-1:2017, Feb. 2017, pp. 1–287.
- [96] *Electric Vehicle Conductive Charging System—Part 23: DC Electric Vehicle Charging Station*, Standard IEC 61851-23:2014, Mar. 2014, pp. 1–159.
- [97] *Electric Vehicle Conductive Charging System—Part 24: Digital Communication Between A D.C. EV Charging Station and an Electric Vehicle for Control of D.C. Charging*, Standard IEC 61851-24:2014, Mar. 2014, pp. 1–63.
- [98] A. Agius. *What's Involved in the Construction of an Ultra-Rapid Electric Car Charging Station?* Accessed: Jul. 10, 2021. [Online]. Available: <https://www.drivezero.com.au/charging/whats-involved-in-the-construction-of-an-ultra-rapidelectric-car-charging-station/>
- [99] M. S. Agamy et al., "An efficient partial power processing DC/DC converter for distributed PV architectures," *IEEE Trans. Power Electron.*, vol. 29, no. 2, pp. 674–686, Feb. 2014.
- [100] W. Yu, J. Lai, H. Ma, and C. Zheng, "High-efficiency DC–DC converter with twin bus for dimmable led lighting," *IEEE Trans. Power Electron.*, vol. 26, no. 8, pp. 2095–2100, Aug. 2011.
- [101] J. Rojas, H. Renaudineau, S. Kouro, and S. Rivera, "Partial power DC–DC converter for electric vehicle fast charging stations," in *Proc. 43rd Annu. Conf. IEEE Ind. Electron. Soc. (IECON)*, Oct. 2017, pp. 5274–5279.
- [102] V. M. Iyer, S. Guler, G. Gohil, and S. Bhattacharya, "An approach towards extreme fast charging station power delivery for electric vehicles with partial power processing," *IEEE Trans. Ind. Electron.*, vol. 67, no. 10, pp. 8076–8087, Oct. 2020, doi: 10.1109/TIE.2019.2945264.
- [103] S. Augustine, J. E. Quiroz, M. J. Reno, and S. Brahma, "DC microgrid protection: Review and challenges," Sandia Nat. Lab., Albuquerque, NM, USA, Tech. Rep. SAND2018-8853, 2018.
- [104] D. Salomonsson, L. Söder, and A. Sannino, "Protection of low-voltage DC microgrids," *IEEE Trans. Power Del.*, vol. 24, no. 3, pp. 1045–1053, Jul. 2009.
- [105] D. M. Bui, S. Chen, C. Wu, K. Lien, C. Huang, and K. Jen, "Review on protection coordination strategies and development of an effective protection coordination system for DC microgrid," in *Proc. IEEE PES Asia-Pacific Power Energy Eng. Conf. (APPEEC)*, Dec. 2014, pp. 1–10.
- [106] J.-D. Park and J. Candelaria, "Fault detection and isolation in low-voltage DC-bus microgrid system," *IEEE Trans. Power Del.*, vol. 28, no. 2, pp. 779–787, Apr. 2013.
- [107] J. W. Kolar and T. Friedli, "The essence of three-phase PFC rectifier systems—Part I," *IEEE Trans. Power Electron.*, vol. 28, no. 1, pp. 176–198, Jan. 2013.
- [108] D. Aggeler, F. Canales, H. Z.-D. La Parra, A. Coccia, N. Butcher, and O. Apeldoorn, "Ultra-fast DC-charge infrastructures for EV-mobility and future smart grids," in *Proc. IEEE PES Innov. Smart Grid Technol. Conf. Eur. (ISGT Europe)*, Oct. 2010, pp. 1–8.
- [109] T. Kang, C. Kim, Y. Suh, H. Park, B. Kang, and D. Kim, "A design and control of bi-directional non-isolated DC–DC converter for rapid electric vehicle charging system," in *Proc. 27th Annu. IEEE Appl. Power Electron. Conf. Expo. (APEC)*, Feb. 2012, pp. 14–21.
- [110] N. Celanovic and D. Boroyevich, "A comprehensive study of neutral point voltage balancing problem in three-level neutral-point-clamped voltage source PWM inverters," *IEEE Trans. Power Electron.*, vol. 15, no. 2, pp. 242–249, Mar. 2000.
- [111] S. Rivera, B. Wu, S. Kouro, V. Yaramasu, and J. Wang, "Electric vehicle charging station using a neutral point clamped converter with bipolar DC bus," *IEEE Trans. Ind. Electron.*, vol. 62, no. 4, pp. 1999–2009, Apr. 2015.
- [112] L. Tan, B. Wu, V. Yaramasu, and X. Guo, "Effective voltage balance control for bipolar-DC-bus-fed EV charging station with three-level DC–DC fast charger," *IEEE Trans. Ind. Electron.*, vol. 63, no. 7, pp. 4031–4041, Jul. 2016.
- [113] H. Akagi, T. Yamagishi, N. M. L. Tan, S.-I. Kinouchi, Y. Miyazaki, and M. Koyama, "Power-loss breakdown of a 750-V 100-kW 20-kHz bidirectional isolated DC–DC converter using SiC-MOSFET/SBD dual modules," *IEEE Trans. Ind. Appl.*, vol. 51, no. 1, pp. 420–428, Feb. 2015.
- [114] J. E. Huber and J. W. Kolar, "Applicability of solid-state transformers in today's and future distribution grids," *IEEE Trans. Smart Grid*, vol. 10, no. 1, pp. 317–326, Jan. 2019.
- [115] N. M. L. Tan, T. Abe, and H. Akagi, "Design and performance of a bidirectional isolated DC–DC converter for a battery energy storage system," *IEEE Trans. Power Electron.*, vol. 27, no. 3, pp. 1237–1248, Mar. 2012.
- [116] H. Wen, W. Xiao, and B. Su, "Nonactive power loss minimization in a bidirectional isolated DC–DC converter for distributed power systems," *IEEE Trans. Ind. Electron.*, vol. 61, no. 12, pp. 6822–6831, Dec. 2014.
- [117] A. Rodríguez, A. Vázquez, D. G. Lamar, M. M. Hernando, and J. Sebastián, "Different purpose design strategies and techniques to improve the performance of a dual active bridge with phase-shift control," *IEEE Trans. Power Electron.*, vol. 30, no. 2, pp. 790–804, Feb. 2015.
- [118] B. Zhao, Q. Song, W. Liu, and W. Sun, "Current-stress-optimized switching strategy of isolated bidirectional DC–DC converter with dual-phase-shift control," *IEEE Trans. Ind. Electron.*, vol. 60, no. 10, pp. 4458–4467, Oct. 2013.
- [119] G. G. Oggier, G. O. García, and A. R. Oliva, "Modulation strategy to operate the dual active bridge DC–DC converter under soft switching in the whole operating range," *IEEE Trans. Power Electron.*, vol. 26, no. 4, pp. 1228–1236, Apr. 2011.
- [120] F. Krismer and J. W. Kolar, "Efficiency-optimized high-current dual active bridge converter for automotive applications," *IEEE Trans. Ind. Electron.*, vol. 59, no. 7, pp. 2745–2760, Jul. 2012.
- [121] J. Huang, Y. Wang, Z. Li, and W. Lei, "Unified triple-phase-shift control to minimize current stress and achieve full soft-switching of isolated bidirectional DC–DC converter," *IEEE Trans. Ind. Electron.*, vol. 63, no. 7, pp. 4169–4179, Jul. 2016.
- [122] J. Hiltunen, V. Väisänen, R. Juntunen, and P. Silventoinen, "Variable-frequency phase shift modulation of a dual active bridge converter," *IEEE Trans. Power Electron.*, vol. 30, no. 12, pp. 7138–7148, Dec. 2015.
- [123] G. G. Oggier and M. Ordonez, "High-efficiency DAB converter using switching sequences and burst mode," *IEEE Trans. Power Electron.*, vol. 31, no. 3, pp. 2069–2082, Mar. 2016.
- [124] A. Taylor, G. Liu, H. Bai, A. Brown, P. M. Johnson, and M. McAmmond, "Multiple-phase-shift control for a dual active bridge to secure zero-voltage switching and enhance light-load performance," *IEEE Trans. Power Electron.*, vol. 33, no. 6, pp. 4584–4588, Jun. 2018.
- [125] W. Chen, P. Rong, and Z. Lu, "Snubberless bidirectional DC–DC converter with new CLLC resonant tank featuring minimized switching loss," *IEEE Trans. Ind. Electron.*, vol. 57, pp. 3075–3086, Sep. 2010.
- [126] Z. U. Zahid, Z. M. Dalala, R. Chen, B. Chen, and J.-S. Lai, "Design of bidirectional DC–DC resonant converter for vehicle-to-grid (V2G) applications," *IEEE Trans. Transport. Electrific.*, vol. 1, no. 3, pp. 232–244, Oct. 2015.
- [127] J.-H. Jung, H.-S. Kim, M.-H. Ryu, and J.-W. Baek, "Design methodology of bidirectional CLLC resonant converter for high-frequency isolation of DC distribution systems," *IEEE Trans. Power Electron.*, vol. 28, no. 4, pp. 1741–1755, Apr. 2013.
- [128] S. Zhao, Q. Li, F. C. Lee, and B. Li, "High-frequency transformer design for modular power conversion from medium-voltage AC to 400 VDC," *IEEE Trans. Power Electron.*, vol. 33, no. 9, pp. 7545–7557, Sep. 2018.

- [129] C.-S. Wang, S.-H. Zhang, Y.-F. Wang, B. Chen, and J.-H. Liu, "A 5-kW isolated high voltage conversion ratio bidirectional CLTC resonant DC-DC converter with wide gain range and high efficiency," *IEEE Trans. Power Electron.*, vol. 34, no. 1, pp. 340–355, Jan. 2019.
- [130] J. Huang et al., "Robust circuit parameters design for the CLLC-type DC transformer in the hybrid AC-DC microgrid," *IEEE Trans. Ind. Electron.*, vol. 66, no. 3, pp. 1906–1918, Mar. 2019.
- [131] B. Li, Q. Li, F. C. Lee, Z. Liu, and Y. Yang, "A high-efficiency high-density wide-bandgap device-based bidirectional on-board charger," *IEEE J. Emerg. Sel. Topics Power Electron.*, vol. 6, no. 3, pp. 1627–1636, Sep. 2018.
- [132] P. He and A. Khaligh, "Design of 1 kW bidirectional half-bridge CLLC converter for electric vehicle charging systems," in *Proc. IEEE Int. Conf. Power Electron., Drives Energy Syst. (PEDES)*, Dec. 2016, pp. 1–6.
- [133] C. Zhang, P. Li, Z. Kan, X. Chai, and X. Guo, "Integrated half-bridge CLLC bidirectional converter for energy storage systems," *IEEE Trans. Ind. Electron.*, vol. 65, no. 5, pp. 3879–3889, May 2018.
- [134] F. Z. Peng, H. Li, G.-J. Su, and J. S. Lawler, "A new ZVS bidirectional DC-DC converter for fuel cell and battery application," *IEEE Trans. Power Electron.*, vol. 19, no. 1, pp. 54–65, Jan. 2004.
- [135] H. Li, D. Liu, F. Z. Peng, and G.-J. Su, "Small signal analysis of a dual half bridge isolated ZVS bi-directional DC-DC converter for electrical vehicle applications," in *Proc. IEEE 36th Power Electron. Spec. Conf.*, Jun. 2005, pp. 2777–2782.
- [136] D. Liu and H. Li, "Design and implementation of a DSP based digital controller for a dual half bridge isolated bi-directional DC-DC converter," in *Proc. 21st Annu. IEEE Appl. Power Electron. Conf. Expo. (APEC)*, Mar. 2006, p. 5.
- [137] O. Garcia, P. Zumel, A. de Castro, and J. A. Cobos, "Automotive DC-DC bidirectional converter made with many interleaved buck stages," *IEEE Trans. Power Electron.*, vol. 21, no. 3, pp. 578–586, May 2006.
- [138] J. Zhang, J.-S. Lai, R.-Y. Kim, and W. Yu, "High-power density design of a soft-switching high-power bidirectional DC-DC converter," *IEEE Trans. Power Electron.*, vol. 22, no. 4, pp. 1145–1153, Jul. 2007.
- [139] D. Christen, F. Jauch, and J. Biel, "Ultra-fast charging station for electric vehicles with integrated split grid storage," in *Proc. 17th Eur. Conf. Power Electron. Appl. (EPE ECCE-Eur.)*, Sep. 2015, pp. 1–11.
- [140] M. T. Zhang, Y. Jiang, F. C. Lee, and M. M. Jovanovic, "Single phase three-level boost power factor correction converter," in *Proc. 10th Annu. IEEE Appl. Power Electron. Conf. Expo.*, vol. 1, Mar. 1995, pp. 434–439.
- [141] P. J. Grbovic, P. Delarue, P. Le Moigne, and P. Bartholomeus, "A bidirectional three-level DC-DC converter for the ultracapacitor applications," *IEEE Trans. Ind. Electron.*, vol. 57, no. 10, pp. 3415–3430, Oct. 2010.
- [142] S. Dusmez, A. Hasanzadeh, and A. Khaligh, "Comparative analysis of bidirectional three-level DC-DC converter for automotive applications," *IEEE Trans. Ind. Electron.*, vol. 62, no. 5, pp. 3305–3315, May 2015.
- [143] R. M. Cuzner, A. R. Bendre, P. J. Faill, and B. Semenov, "Implementation of a non-isolated three level DC/DC converter suitable for high power systems," in *Proc. IEEE Ind. Appl. Annu. Meeting*, Sep. 2007, pp. 2001–2008.
- [144] L. Tan, N. Zhu, and B. Wu, "An integrated inductor for eliminating circulating current of parallel three-level DC-DC converter-based EV fast charger," *IEEE Trans. Ind. Electron.*, vol. 63, no. 3, pp. 1362–1371, Mar. 2016.
- [145] Y. Du, X. Zhou, S. Bai, S. Lukic, and A. Huang, "Review of non-isolated bi-directional DC-DC converters for plug-in hybrid electric vehicle charge station application at municipal parking decks," in *Proc. 25th Annu. IEEE Appl. Power Electron. Conf. Expo. (APEC)*, Feb. 2010, pp. 1145–1151.
- [146] L. Tan, B. Wu, S. Rivera, and V. Yaramasu, "Comprehensive DC power balance management in high-power three-level DC-DC converter for electric vehicle fast charging," *IEEE Trans. Power Electron.*, vol. 31, no. 1, pp. 89–100, Jan. 2016.
- [147] Z. Zhang et al., "High-efficiency silicon carbide (SiC) converter using paralleled discrete devices in energy storage systems," in *Proc. IEEE Energy Convers. Congr. Expo. (ECCE)*, Sep. 2019, pp. 2471–2477.
- [148] W. Qian, H. Cha, F. Z. Peng, and L. M. Tolbert, "55-kW variable 3X DC-DC converter for plug-in hybrid electric vehicles," *IEEE Trans. Power Electron.*, vol. 27, no. 4, pp. 1668–1678, Apr. 2012.
- [149] J. W. Kolar and J. E. Huber, "Solid-state transformers-key design challenges, applicability, and future concepts," in *Proc. 17th Int. Conf. Power Electron. Motion Control (PEMC)*, Varna, Bulgaria, Sep. 2016, p. 26.
- [150] Q. Zhu, L. Wang, A. Q. Huang, K. Booth, and L. Zhang, "7.2-kV single-stage solid-state transformer based on the current-fed series resonant converter and 15-kV SiC MOSFETs," *IEEE Trans. Power Electron.*, vol. 34, no. 2, pp. 1099–1112, Feb. 2019.
- [151] X. She, A. Q. Huang, S. Lukic, and M. E. Baran, "On integration of solid-state transformer with zonal DC microgrid," *IEEE Trans. Smart Grid*, vol. 3, no. 2, pp. 975–985, Jun. 2012.
- [152] F. Heider, M. Büttner, J. Link, and C. Wittwer, "Vehicle to grid: Realization of power management for the optimal integration of plug-in electric vehicles into the grid," in *Proc. Int. Battery, Hybrid Fuel Cell Electr. Vehicle Symp. (EVS)*, Stavanger, Norway, 2009, pp. 1–12.
- [153] S. Deb, K. Kalita, and P. Mahanta, "Review of impact of electric vehicle charging station on the power grid," in *Proc. Int. Conf. Technol. Advancements Power Energy (TAP Energy)*, Dec. 2017, pp. 1–6, doi: 10.1109/TAPENERGY.2017.8397215.
- [154] S. Deb, K. Tammi, K. Kalita, and P. Mahanta, "Impact of electric vehicle charging station load on distribution network," *Energies*, vol. 11, no. 1, p. 178, Jan. 2018.
- [155] G. Gamboa, C. Hamilton, R. Kerley, S. Elmes, A. Arias, J. Shen, and I. Batarseh, "Control strategy of a multi-port, grid connected, direct-DC PV charging station for plug-in electric vehicles," in *Proc. Energy Convers. Congr. Expo. (ECCE)*, 2010, pp. 1173–1177.
- [156] S. Deb, K. Tammi, K. Kalita, and P. Mahanta, "Review of recent trends in charging infrastructure planning for electric vehicles," *WIREs Energy Environ.*, vol. 7, no. 6, p. 306, 2018, doi: 10.1002/wene.306.
- [157] S. M. Shariff, M. S. Alam, F. Ahmad, Y. Rafat, M. S. J. Asghar, and S. Khan, "System design and realization of a solar-powered electric vehicle charging station," *IEEE Syst. J.*, vol. 14, no. 2, pp. 2748–2758, Jun. 2020, doi: 10.1109/JSYST.2019.2931880.
- [158] O. C. Onar and A. Khaligh, "Grid interactions and stability analysis of distribution power network with high penetration of plug-in hybrid electric vehicles," in *Proc. 25th Annu. IEEE Appl. Power Electron. Conf. Expo. (APEC)*, Feb. 2010, pp. 1755–1762.
- [159] T. Das and D. C. Aliprantis, "Small-signal stability analysis of power system integrated with PHEVs," in *Proc. IEEE Energy Conf.*, Nov. 2008, pp. 1–4.
- [160] J. Yan, G. Xu, H. Qian, and Y. Xu, "Battery fast charging strategy based on model predictive control," in *Proc. IEEE 72nd Veh. Technol. Conf.-Fall*, Sep. 2010, pp. 1–8.
- [161] B. Wang, D. Zhao, P. Dehghanian, Y. Tian, and T. Hong, "Aggregated electric vehicle load modeling in large-scale electric power systems," *IEEE Trans. Ind. Appl.*, vol. 56, no. 5, pp. 5796–5810, Sep. 2020.
- [162] U. C. Chukwu, "The impact of load patterns on power loss: A case of V2G in the distribution network," in *Proc. Clemson Univ. Power Syst. Conf. (PSC)*, Mar. 2020, pp. 1–4, doi: 10.1109/PSC50246.2020.9131314.
- [163] U. C. Chukwu, "The impact of V2G on power factors," in *Proc. Clemson Univ. Power Syst. Conf. (PSC)*, Mar. 2020, pp. 1–4, doi: 10.1109/PSC50246.2020.9131328.
- [164] D. McCarthy and P. Wolfs, "The HV system impacts of large scale electric vehicle deployments in a metropolitan area," in *Proc. 20th Australas. Univ. Power Eng. Conf.*, 2010, pp. 1–6.
- [165] K. Kaur, S. Garg, G. Kaddoum, S. H. Ahmed, F. Gagnon, and M. Atiquzzaman, "Demand-response management using a fleet of electric vehicles: An opportunistic-SDN-based edge-cloud framework for smart grids," *IEEE Netw.*, vol. 33, no. 5, pp. 46–53, Sep. 2019, doi: 10.1109/MNET.001.1800496.
- [166] G. A. Putrus, P. Suwanapingkarl, D. Johnston, E. C. Bentley, and M. Narayana, "Impact of electric vehicles on power distribution networks," in *Proc. IEEE Vehicle Power Propuls. Conf.*, Sep. 2009, pp. 827–831.
- [167] M. Mahalik, L. Poch, A. Botterud, and A. Vyas, "Impacts of plug-in hybrid electric vehicles on the electric power system in Illinois," in *Proc. IEEE Conf. Innov. Technol. Efficient Reliable Electr. Supply*, Sep. 2010, pp. 341–348.
- [168] H. Yano, K. Kudo, T. Ikegami, H. Iguchi, K. Kataoka, and K. Ogimoto, "A novel charging-time control method for numerous EVs based on a period weighted prescheduling for power supply and demand balancing," in *Proc. IEEE PES Innov. Smart Grid Technol. (ISGT)*, Jan. 2012, pp. 1–6, doi: 10.1109/ISGT.2012.6175612.
- [169] S. Canevese, D. Cirio, M. Gallanti, and A. Gatti, "EV flexibility supply via participation in balancing services: Possible profitability for Italian end users," in *Proc. AEIT Int. Annu. Conf. (AEIT)*, Sep. 2019, pp. 1–6, doi: 10.23919/AEIT.2019.8893332.



- [170] I. S. Bayram, G. Michailidis, and M. Devtsikiotis, "Unsplittable load balancing in a network of charging stations under QoS guarantees," *IEEE Trans. Smart Grid*, vol. 6, no. 3, pp. 1292–1302, May 2015, doi: [10.1109/TSG.2014.2362994](https://doi.org/10.1109/TSG.2014.2362994).
- [171] M. A. H. Rafi and J. Bauman, "A comprehensive review of DC fast-charging stations with energy storage: Architectures, power converters, and analysis," *IEEE Trans. Transport. Electrification*, vol. 7, no. 2, pp. 345–368, Jun. 2021, doi: [10.1109/TTE.2020.3015743](https://doi.org/10.1109/TTE.2020.3015743).
- [172] O. Beaude, S. Lasaulce, M. Hennebel, and I. Mohand-Kaci, "Reducing the impact of EV charging operations on the distribution network," *IEEE Trans. Smart Grid*, vol. 7, no. 6, pp. 2666–2679, Nov. 2016, doi: [10.1109/TSG.2015.2489564](https://doi.org/10.1109/TSG.2015.2489564).
- [173] N. Rodrigues, J. Sharma, S. Vyas, and A. Datta, "A regulated electric vehicle charging scheme in coordination with utility pricing and transformer loading," in *Proc. IEEE Transp. Electrification Conf. (ITEC-India)*, Dec. 2019, pp. 1–5, doi: [10.1109/ITEC-India48457.2019.ITECINDIA2019-135](https://doi.org/10.1109/ITEC-India48457.2019.ITECINDIA2019-135).
- [174] S. A. A. Rizvi, A. Xin, A. Masood, S. Iqbal, M. U. Jan, and H. Rehman, "Electric vehicles and their impacts on integration into power grid: A review," in *Proc. 2nd IEEE Conf. Energy Internet Energy Syst. Integr. (EI)*, Oct. 2018, pp. 1–6, doi: [10.1109/EI2.2018.8582069](https://doi.org/10.1109/EI2.2018.8582069).
- [175] S. Hutchinson, M. Baran, and S. Lukic, "Power supply for an electric vehicle charging system for a large parking deck," in *Proc. IEEE Ind. Appl. Soc. Annu. Meeting (IAS)*, Oct. 2009, pp. 1–6.
- [176] P. Papadopoulos, S. Skarvelis-Kazakos, I. Grau, B. Awad, L. M. Cipcigan, and N. Jenkins, "Impact of residential charging of electric vehicles on distribution networks, a probabilistic approach," in *Proc. Univ. Power Eng. Conf. (UPEC)*, 2010, pp. 1–5.
- [177] A. Hajimiragha, C. A. Canizares, M. W. Fowler, and A. Elkamel, "Optimal transition to plug-in hybrid electric vehicles in Ontario, Canada, considering the electricity-grid limitations," *IEEE Trans. Ind. Electron.*, vol. 57, no. 2, pp. 690–701, Feb. 2010, doi: [10.1109/TIE.2009.2025711](https://doi.org/10.1109/TIE.2009.2025711).
- [178] H. Ramadan, A. Ali, and C. Farkas, "Assessment of plug-in electric vehicles charging impacts on residential low voltage distribution grid in Hungary," in *Proc. 6th Int. Istanbul Smart Grids Cities Congr. Fair (ICSG)*, Apr. 2018, pp. 105–109, doi: [10.1109/SGCF.2018.8408952](https://doi.org/10.1109/SGCF.2018.8408952).
- [179] S. Blumsack, C. Samaras, and P. Hines, "Long-term electric system investments to support plug-in hybrid electric vehicles," in *Proc. IEEE Power Energy Soc. Gen. Meeting-Convers. Del. Electr. Energy 21st Century*, Jul. 2008, pp. 1–6.
- [180] C. Farmer, P. Hines, J. Dowds, and S. Blumsack, "Modeling the impact of increasing PHEV loads on the distribution infrastructure," in *Proc. 43rd Hawaii Int. Conf. Syst. Sci. (HICSS)*, 2010, pp. 1–10.
- [181] L. P. Fernández, T. G. S. Román, R. Cossent, C. M. Domingo, and P. Frías, "Assessment of the impact of plug-in electric vehicles on distribution networks," *IEEE Trans. Power Syst.*, vol. 26, no. 1, pp. 206–213, Feb. 2011, doi: [10.1109/TPWRS.2010.2049133](https://doi.org/10.1109/TPWRS.2010.2049133).
- [182] V. Zdravski, P. Krstevski, J. Vuletic, J. Angelov, A. K. Mateska, and M. Todorovski, "Analyzing the impact of battery electric vehicles on distribution networks using nondeterministic model," in *Proc. IEEE 18th Int. Conf. Smart Technol. (EUROCON)*, Jul. 2019, pp. 1–7, doi: [10.1109/EUROCON.2019.8861984](https://doi.org/10.1109/EUROCON.2019.8861984).
- [183] E. Veldman, M. Gibescu, and A. Postma, "Unlocking the hidden potential of electricity distribution grids," in *Proc. 20th Int. Conf. Exhib. Electr. Distrib. (CIRED)*, vol. 1, 2009, pp. 1–4.
- [184] J. Schlee, A. Mousseau, J. Eggebraaten, B. Johnson, H. Hess, and B. Johnson, "The effects of plug-in electric vehicles on a small distribution grid," in *Proc. 41st North Amer. Power Symp.*, Oct. 2009, pp. 1–6, doi: [10.1109/NAPS.2009.5484055](https://doi.org/10.1109/NAPS.2009.5484055).
- [185] P. B. Evans, S. Kuloor, and B. Kroposki, "Impacts of plug-in vehicles and distributed storage on electric power delivery networks," in *Proc. IEEE Vehicle Power Propuls. Conf.*, Sep. 2009, pp. 838–846, doi: [10.1109/VPPC.2009.5289761](https://doi.org/10.1109/VPPC.2009.5289761).
- [186] J. A. P. Lopes, F. J. Soares, P. M. R. Almeida, P. C. Baptista, C. M. Silva, and T. L. Farias, "Quantification of technical impacts and environmental benefits of electric vehicles integration on electricity grids," in *Proc. 8th Int. Symp. Adv. Electromech. Motion Syst. Electr. Drives Joint Symp.*, Jul. 2009, pp. 1–6, doi: [10.1109/ELECTROMOTION.2009.5259139](https://doi.org/10.1109/ELECTROMOTION.2009.5259139).
- [187] M. Tabari and A. Yazdani, "A DC distribution system for power system integration of plug-in hybrid electric vehicles," in *Proc. IEEE Power Energy Soc. Gen. Meeting*, Jul. 2013, pp. 1–5, doi: [10.1109/PESMG.2013.6672772](https://doi.org/10.1109/PESMG.2013.6672772).
- [188] J. A. Orr, A. E. Emanuel, and D. G. Pileggi, "Current harmonics, voltage distortion, and powers associated with battery chargers Part I: Comparisons among different types of chargers," in *IEEE Trans. Power App. Syst.*, vol. PAS-101, no. 8, pp. 2703–2710, Aug. 1982, doi: [10.1109/TPAS.1982.317641](https://doi.org/10.1109/TPAS.1982.317641).
- [189] T. Song, P. Wang, Y. Zhang, F. Gao, Y. Tang, and S. Pholboon, "Suppression method of current harmonic for three-phase PWM rectifier in EV charging system," *IEEE Trans. Veh. Technol.*, vol. 69, no. 9, pp. 9634–9642, Sep. 2020, doi: [10.1109/TVT.2020.3005173](https://doi.org/10.1109/TVT.2020.3005173).
- [190] L. Kutt, E. Saarijärvi, M. Lehtonen, H. Mölder, and J. Niitsoo, "Harmonic distortions of multiple power factor compensated EV chargers," in *Proc. 16th Eur. Conf. Power Electron. Appl.*, Aug. 2014, pp. 1–7, doi: [10.1109/EPE.2014.6911035](https://doi.org/10.1109/EPE.2014.6911035).
- [191] A. Megha, N. Mahendran, and R. Elizabeth, "Analysis of harmonic contamination in electrical grid due to electric vehicle charging," in *Proc. 3rd Int. Conf. Smart Syst. Inventive Technol. (ICSSIT)*, Aug. 2020, pp. 608–614, doi: [10.1109/ICSSIT48917.2020.9214096](https://doi.org/10.1109/ICSSIT48917.2020.9214096).
- [192] L. Kütt, E. Saarijärvi, M. Lehtonen, H. Mölder, and J. Niitsoo, "Electric vehicle charger load current harmonics variations due to supply voltage level differences—Case examples," in *Proc. Int. Symp. Power Electron., Electr. Drives, Automat. Motion*, 2014, pp. 917–922, doi: [10.1109/SPEEDAM.2014.6872009](https://doi.org/10.1109/SPEEDAM.2014.6872009).
- [193] S. Rahman and G. B. Shrestha, "An investigation into the impact of electric vehicle load on the electric utility distribution system," *IEEE Trans. Power Del.*, vol. 8, no. 2, pp. 591–597, Apr. 1993, doi: [10.1109/61.216865](https://doi.org/10.1109/61.216865).
- [194] K. Clement, E. Haesen, and J. Driesen, "Stochastic analysis of the impact of plug-in hybrid electric vehicles on the distribution grid," in *Proc. 20th Int. Conf. Exhib. Electr. Distrib. (CIRED)*, vol. 2, 2009, pp. 1–7.
- [195] H. Wu, M. Shahidehpour, A. Alabdulwahab, and A. Abusorrah, "A game theoretic approach to risk-based optimal bidding strategies for electric vehicle aggregators in electricity markets with variable wind energy resources," *IEEE Trans. Sustain. Energy*, vol. 7, no. 1, pp. 374–385, Jan. 2016, doi: [10.1109/TSTE.2015.2498200](https://doi.org/10.1109/TSTE.2015.2498200).
- [196] M. C. Falvo, D. Sbordone, I. S. Bayram, and M. Devtsikiotis, "EV charging stations and modes: International standards," in *Proc. Int. Symp. Power Electron., Electr. Drives, Automat. Motion*, Jun. 2014, pp. 1134–1139.
- [197] *Society of Automation Engineering—International Standards on EV Charging Stations*. Accessed: Jul. 10, 2021. [Online]. Available: <https://www.sae.org/>
- [198] *IEEE Standard for Interconnection and Interoperability of Distributed Energy Resources With Associated Electric Power Systems Interfaces*, IEEE Standard 1547-2018, 2018.
- [199] UL Laboratories. *Electric Vehicle Infrastructure Services—UL*. Accessed: Jul. 10, 2021. [Online]. Available: <https://www.ul.com/services/electric-vehicle-ev-infrastructure-services>
- [200] *NFPA 70: National Electrical Code*, Nat. Fire Protection Assoc., Quincy, MA, USA, 2011.
- [201] *Electric Vehicle Charging Stations—Standards*. Accessed: Jul. 10, 2021. [Online]. Available: <https://www.iso.org/standards.html>
- [202] (2018). *CHAdEMO Protocol Development*. [Online]. Available: <https://www.chademo.com/activities/protocol-development/>
- [203] *Top 10 Countries in the Global EV Revolution*. [Online]. Available: [Online]. Available as on 10.07.2021: <https://insideeVs.com/news/402528/top-10-global-ev-countries-2019/>
- [204] *IEC-Electric Vehicles Charging Stations*. Accessed: Jul. 10, 2021. [Online]. Available: <https://www.iec.ch/transportation/electricvehicles>



**MOHD RIZWAN KHALID** (Member, IEEE) received the B.Tech. and M.Tech. degrees in electrical engineering from Zakir Husain College of Engineering and Technology, Aligarh Muslim University, Aligarh, India, where he is currently pursuing the Ph.D. degree with the Department of Electrical Engineering.

Previously, he was a Student Research Associate and a Project Engineer with the Indian Institute of Technology Kanpur, Kanpur, India. His research interests include power electronics, power quality, electric mobility, and xEVs charging infrastructure.



**IRFAN A. KHAN** (Senior Member, IEEE) received the Ph.D. degree in electrical and computer engineering from Carnegie Mellon University, USA.

He is currently an Assistant Professor with the Department of Marine Engineering Technology with a joint appointment at the Department of Electrical and Computer Engineering, Texas A&M University, College Station. He is also the Director of the Clean And Resilient Energy Systems (CARES) Laboratory that focuses on the reliability, sustainability, and security of the electric energy supply on marine vessels. He is an Affiliate Faculty Member of the TAMU Energy Institute and the TEES Smart Grid Center. He has been fortunate to receive several grants from multiple funding agencies to work on marine electric distribution systems, electric vehicle fast charging, and electric microgrids. He has done pioneering work in distributed grids and shipboard power systems monitoring. His current research interests include the optimization, control, and monitoring of smart energy networks, optimization of energy storage systems, DC microgrids, smart grids, and renewable energy resources. He has published more than 75 refereed reputed journal articles and peer-reviewed conference papers in the smart energy systems-related areas. He is a Registered Professional Engineer (P.E.) with TX, USA. He is the Vice Chair of the IEEE Galveston Bay Section (GBS) of Region 5. He was the Registration Chair at the IEEE Sponsored International Symposium on Measurement and Control in Robotics, organized at the University of Houston–Clear Lake, in September 2019. He has organized several special sessions at various international conferences. Further, he is a regular reviewer of more than 40 reputed journals and conferences, wherein the year 2020, he reviewed more than 230 articles. He is also helping with editorial responsibilities at various journals, namely IEEE TRANSACTIONS ON INDUSTRY APPLICATIONS, IEEE ACCESS, *Energies* (MDPI), *Electronics* (MDPI), and *Frontiers in Energy Research*.



**SALMAN HAMEED** (Member, IEEE) received the B.Sc.Engg. (electrical) and M.Sc.Engg. (power system and drives) degrees from the Department of Electrical Engineering, Aligarh Muslim University (AMU), Aligarh, India, in 1988 and 1991, respectively, and the Ph.D. degree in the area of power system (FACTS controllers) from IIT Roorkee, Roorkee, India, in 2008. He has been an Advisor to UPSC, New Delhi. He is currently working as a Professor with the Department of Electrical Engineering, AMU. He is also the Chairperson of the Department of Electrical Engineering, AMU. He is supervising four Ph.D. thesis and four Ph.D. thesis have been already supervised. He has published several research papers in national and international journals, like *International Journal of Electrical Power and Energy Systems* (Elsevier) and *Electric Power Systems Research* (Elsevier) and in various international and national conference proceedings in India and abroad. He has also visited Yokohama, Japan, to present a paper at IEEE conference, in October 2002. His teaching and research lies mainly in the area of power systems, applications of AI techniques in power systems, fuzzy logic controller, and application of nano technology in solar PV cells. He is a Life Member of the System Society of India. He was an Expert Committee Member of the All India Council for Technical Education (AICTE), Central Regional Office, Bhopal, for the period 2011–12. He was a Gold Medalist and a recipient of University Merit Scholarship from AMU. He was also a recipient of a QIP Research Fellowship from IIT Roorkee. He has also chaired a number of technical session in the International and national conferences, including a technical session held at Vancouver, Canada, in August 2014 [International Conference on Power Systems Engineering (ICPSE) 2014]. He has delivered many invited talks at various institutes outside Aligarh.



**M. SYED JAMIL ASGHAR** (Member, IEEE) was born in Patna, India. He received the B.Sc.Engg. (electrical), M.Sc.Engg. (power systems), and Ph.D. (power electronics) degrees from Aligarh Muslim University, Aligarh, India.

He had joined the Department of Electrical Engineering, Aligarh Muslim University, in 1983, as a Lecturer/an Assistant Professor, where he has been a Professor, since 1999. He has established the Centre of Renewable Energy in the Department

of Electrical Engineering, funded by the Government of India. He is the Coordinator of DRS Program under Special Assistance Program (SAP) of the University Grants Commission (UGC), Government of India. The scheme was granted, for five years, with an amount of Rs. 43.4 Lac. The scheme is continued with a grant of 85 Lac, for the next five years, and the focus of the research project is a renewable energy-based smart grid. He has successfully completed many government-funded research projects, and guided many research thesis (eight) and M.Tech. dissertations (24). He has published more than 90 papers in referred journals and conference-proceedings, including several single-authored papers in IEEE TRANSACTIONS, USA. He has written a textbook *Power Electronics* (Prentice-Hall of India/PHI Learning) and is a Chapter author (Gate Drive Circuits, Chapter#18) of *Power Electronics Handbook* (Academic/Elsevier, California, USA) under a joint program of the University of West Florida and the University of Florida, USA. He has several patents to his credit related to renewable energy (total 20 patents). It includes a discontinuous phase-controlled switching systems, analog MPPT solar PV systems, grid-tied high power thyristor-based solar PV systems, and novel flexible asynchronous AC link (FASAL) for grid failure mitigation. His research and teaching interests include power electronics, renewable energy systems, and electrical machines.

Dr. Asghar is a fellow of IETE, India.



**JONG-SUK RO** received the B.S. degree in mechanical engineering from Hanyang University, Seoul, South Korea, in 2001, and the Ph.D. degree in electrical engineering from Seoul National University (SNU), Seoul, in 2008.

From 2008 to 2012, he conducted research at the Research and Development Center, Samsung Electronics, as a Senior Engineer. From 2012 to 2013, he was with the Brain Korea 21 Information Technology, SNU, as a Postdoctoral Fellow. From 2013 to 2016, he worked with the Brain Korea 21 Plus, SNU, as a BK Assistant Professor. In 2013, he conducted research at the Division of Electrical Energy Conversion System Research, Korea Electrical Engineering & Science Research Institute, as a Researcher. In 2014, he was with the University of Bath, Bath, U.K., as an Academic Visitor. He is currently an Associate Professor with the School of Electrical and Electronics Engineering and an Adjunct Professor with the Department of Intelligent Energy and Industry, Chung-Ang University, Seoul. His research interest includes the analysis and optimal design of intelligent energy conversion systems, such as actuator, generator, and transformer using smart materials, namely electromagnetism, piezoelectric, and shape memory alloy.

...