



Space–time line coded spatial modulation

Ki-Hun Lee,¹  Jingon Jung,² 
and Bang Chul Jung^{1,✉} 

¹Department of Electronics Engineering, Chungnam National University, Daejeon, South Korea

²School of Electrical and Electronics Engineering, Chung-Ang University, Seoul, South Korea

✉ Email: bcjung@cnu.ac.kr

In this letter, a novel multiple-input multiple-output transceiver technique, named space–time line coded spatial modulation (STLC-SM) is proposed, where two modulation symbols are transmitted through one of the multiple transmit antennas determined by the incoming information bits after constellation-rotated STLC encoding. The receiver decodes the transmitted modulation symbols and the activated antenna index through an optimal joint maximum-likelihood detector. As a main result, the closed-form upper-bound of bit-error-rate of the proposed STLC-SM system in general antenna configurations is mathematically analysed. Finally, it is validated that the STLC-SM significantly outperforms the conventional STLC in terms of the bit-error-rate.

Introduction: Spatial modulation (SM) [1] is recently being re-emerged as one of the promising techniques for next-generation multiple-input multiple-output (MIMO) Internet of things (IoT) networks [2]. The basic idea of the SM is to extend two-dimension signals (amplitude and phase modulation: APM) into the three-dimensional signal space by exploiting the spatial (the index of active transmit antenna) domain. By activating a single transmit antenna to convey information bit sequence at each time-slot, the inter-antenna synchronisation requirement is relaxed and inter-channel interference (ICI) is completely eliminated. On the other hand, the data rate of the single-antenna selecting SM can be increased logarithmically with the total number of transmit antennas. Furthermore, it can be designed with a single radio frequency (RF) chain at the transmitter (TX) by using the antenna-switching mechanism.

On the other hand, space–time line code (STLC) has recently been proposed as a symmetric technique of the space–time block code (STBC) [3]. The STLC is implemented through the simple linear encoding and decoding procedure, enabling low-complexity implementation. Thanks to these advantages, STLC-based communication techniques are being actively studied [4]. In this letter, we investigate a space–time line coded spatial modulation (STLC-SM) as the counterpart technique of the space–time block coded spatial modulation (STBC-SM) [5] for MIMO IoT networks. To the best of our knowledge, this study is the first attempt to amalgamate the SM technique with STLC to exploit the benefits of them.

System model: We consider an $N \times 2$ MIMO communication system, where a TX is equipped with N antennas and a receiver (RX) is equipped with dual antennas as illustrated in Figure 1. We assume that $N = 2^c$

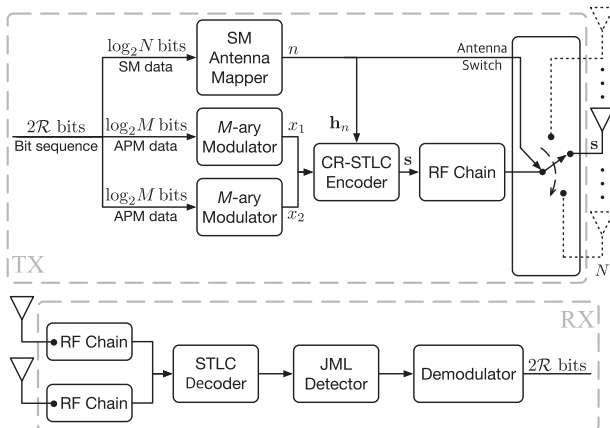

Fig. 1 System model of the STLC-SM in an $N \times 2$ MIMO system

($c \in \mathbb{N}$) and the TX has a single RF chain for low-complexity and cost-effectiveness of IoT devices. The results obtained from this study can be readily extended to the STLC-SM systems with multiple RX antennas more than two by exploiting the low-rate STLC schemes in ref. [3]. Full channel state information (CSI) between the TX and the RX is known at the TX (i.e. CSIT), whereas only partial CSI is known at the RX.

The TX modulates bit sequence into two M -quadrature amplitude modulation (QAM) symbols and selects a transmit antenna according to the additional bits to convey through antenna index. Then, M -QAM symbols are encoded into two constellation-rotated STLC (CR-STLC) signals by using the CSI between the selected transmit antenna and two receive antennas. The basic concept of the CR-STLC is to rotate the constellation of the M -QAM symbols to a certain angle before STLC encoding. Therefore, CR-STLC signals transmitted at the time-slot t ($t \in \{1, 2\}$), denoted by s_t , can be represented as follows:

$$s_1 = \sqrt{P} \frac{h_{n,1}^* x_1 e^{j\theta_n} + h_{n,2}^* x_2 e^{-j\theta_n}}{\sqrt{|h_{n,1}|^2 + |h_{n,2}|^2}}, \quad \text{for } t = 1, \quad (1)$$

$$s_2 = \sqrt{P} \frac{h_{n,2}^* x_1 e^{-j\theta_n} - h_{n,1}^* x_2 e^{j\theta_n}}{\sqrt{|h_{n,1}|^2 + |h_{n,2}|^2}}, \quad \text{for } t = 2,$$

where x_t denotes the normalised M -QAM symbol corresponding to the time-slot t , i.e. $\mathbb{E}[|x_t|^2] = 1$, and $h_{n,m}$ denotes the wireless channel coefficient between n ($n \in \mathcal{N} = \{1, \dots, N\}$)th antenna of the TX and m ($m \in \{1, 2\}$)th antenna of the RX. Here, without loss of generality (w.l.o.g.), the n th transmit antenna is assumed to be selected. In this letter, all channels are assumed to conform to independently and identically distributed (i.i.d.) complex Gaussian distribution with a zero mean and a unit variance, i.e. $h_{n,m} \sim \mathcal{CN}(0, 1)$, $\forall n, m$. Also, θ_n [$^\circ$] and P represent the constellation rotation angle of the n th transmit antenna and the average transmit power of two STLC signals, respectively, such that $\mathbb{E}[\|\mathbf{s}\|^2] = 2P$, where $\mathbf{s} = [s_1 \ s_2]^T$. Herein, since two STLC signals are transmitted through the same transmit antenna, the spectral efficiency of the STLC-SM system can be calculated as $\mathcal{R} = \frac{1}{2} \log_2 N + \log_2 M$ [bps/Hz].

Two STLC signals, s_1 and s_2 , are consequently transmitted to the RX. During each transmission, the wireless channels are assumed to be static. The received signals at receive antennas can then be expressed as a matrix form as follows:

$$\begin{bmatrix} y_{1,1} & y_{1,2} \\ y_{2,1} & y_{2,2} \end{bmatrix} = \sqrt{\delta^{-\alpha}} \begin{bmatrix} h_{n,1} \\ h_{n,2} \end{bmatrix} \begin{bmatrix} s_1 & s_2 \end{bmatrix} + \begin{bmatrix} w_{1,1} & w_{1,2} \\ w_{2,1} & w_{2,2} \end{bmatrix}, \quad (2)$$

where $y_{m,t}$ and $w_{m,t}$ denote the received signal and thermal noise at the m th receive antenna at the time-slot t of the RX, respectively; and $w_{m,t} \sim \mathcal{CN}(0, N_0)$, $\forall m, t$. Also, δ and α denote the distance between TX and RX, and the path-loss exponent, respectively.

The RX then performs STLC decoding with the simple linear combination of the received signals in Equation (2) as follows:

$$\bar{y}_1 = y_{1,1} + y_{2,2}^* = \sqrt{P\delta^{-\alpha}} \|\mathbf{h}_n\| x_1 e^{j\theta_n} + w_{1,1} + w_{2,2}^*, \quad (3)$$

$$\bar{y}_2 = y_{2,1}^* - y_{1,2} = \sqrt{P\delta^{-\alpha}} \|\mathbf{h}_n\| x_2 e^{j\theta_n} + w_{2,1}^* - w_{1,2},$$

where \bar{y}_t represents the t th STLC decoding signal. We can easily observe that each \bar{y}_t has the M -QAM signal corresponding to the time-slot t without phase distortion by the wireless channel and that thermal noise variance is doubled to $2N_0$. Note that θ_n is the intentional rotation angle from the TX and is predetermined by the transmit antenna index n .

From Equation (3), the RX detects the transmitted M -QAM symbols and the activated antenna index of the TX by employing a joint maximum-likelihood (JML) detector considering rotation angle θ_n . Let γ_n denote the effective channel gain of the n th antenna of the TX defined as $\gamma_n \triangleq \|\mathbf{g}_n\|^2$, where $\mathbf{g}_n \triangleq \sqrt{\delta^{-\alpha}} \mathbf{h}_n$, i.e. $\mathbf{g}_n \sim \mathcal{CN}(\mathbf{0}, \delta^{-\alpha} \cdot \mathbf{I}_2)$. Here, we assume that the RX has the partial CSI, which is the effective channel gain of each transmit antenna γ_n , by using the machine learning-based blind energy detection method [6]. Also, θ_n s are pre-designed according

to the number of transmit antennas and are known at the RX. The JML detection can then be performed as follows:

$$[\hat{x}_1, \hat{x}_2, \hat{n}] = \arg \min_{x_1, x_2 \in \mathcal{X}, n \in \mathcal{N}} \left\| \begin{bmatrix} \bar{y}_1 \\ \bar{y}_2 \end{bmatrix} - \sqrt{P} \sqrt{\gamma_n} e^{j\theta_n} \begin{bmatrix} x_1 \\ x_2 \end{bmatrix} \right\|^2, \quad (4)$$

where \hat{x}_i and \hat{n} represent the detected M -QAM symbols and transmit antenna index, respectively, and \mathcal{X} is a set of constellation points of the normalised M -QAM symbols.

Performance analysis: In this section, we analyse the bit-error-rate (BER) performance of the STLC-SM system that employs the 4-QAM modulator for energy-efficiency and low-complexity of IoT devices, i.e. $M = 4$. That is, we define that $\mathcal{X} \triangleq \{c_1, c_2, c_3, c_4\} = \left\{ \frac{-1+j}{\sqrt{2}}, \frac{-1-j}{\sqrt{2}}, \frac{1+j}{\sqrt{2}}, \frac{1-j}{\sqrt{2}} \right\}$, and each 4-QAM symbol sequentially represents bits 00, 01, 10, and 11 according to the grey mapping rule. Other cases, when $M \neq 4$, can also be analysed through the same procedure as that for $M = 4$.

Based on the improved BER upper bound of SM-MIMO systems [7], the BER performance of the STLC-SM system, denoted by P_b , can be upper bounded as follows:

$$P_b \leq \text{BER}_{\text{signal}} + \text{BER}_{\text{spatial}} + \text{BER}_{\text{joint}}, \quad (5)$$

where $\text{BER}_{\text{signal}}$, $\text{BER}_{\text{spatial}}$, and $\text{BER}_{\text{joint}}$ are defined in Equation (6) at the top of this page.

$$\left\{ \begin{aligned} \text{BER}_{\text{signal}} &= \frac{1}{2} \frac{1}{N} \frac{\log_2 M^2}{\log_2(NM^2)} \sum_{n=1}^N \frac{1}{M^2} \frac{1}{\log_2 M^2} \sum_{i=1}^M \sum_{j=1}^M \sum_{i=1}^M \sum_{j=1}^M \left[\delta_H(c_i, c_j \rightarrow c_i, c_j) \mathbb{E}_{\gamma_n} \left[\mathcal{Q} \left(\sqrt{\frac{\|\mathbf{d}_{i,j,n,n}\|^2}{4N_0}} \right) \right] \right] \\ \text{BER}_{\text{spatial}} &= \frac{1}{M^2} \frac{\log_2 N}{\log_2(NM^2)} \sum_{i=1}^M \sum_{j=1}^M \frac{1}{N} \frac{1}{\log_2 N} \sum_{k=1}^N \sum_{l=1}^N \left[\delta_H(n_k \rightarrow n_l) \mathbb{E}_{\gamma_k, \gamma_l} \left[\mathcal{Q} \left(\sqrt{\frac{\|\mathbf{d}_{i,j,k,l}\|^2}{4N_0}} \right) \right] \right] \\ \text{BER}_{\text{joint}} &= \frac{1}{NM^2} \frac{1}{\log_2(NM^2)} \sum_{k=1}^N \sum_{i=1}^M \sum_{j=1}^M \sum_{\substack{l=1 \\ l \neq k}}^N \sum_{\substack{i=1 \\ i \neq l}}^M \sum_{\substack{j=1 \\ j \neq i}}^M \left[\delta_H(c_i, c_j, n_k \rightarrow c_i, c_j, n_l) \mathbb{E}_{\gamma_k, \gamma_l} \left[\mathcal{Q} \left(\sqrt{\frac{\|\mathbf{d}_{i,j,k,l}\|^2}{4N_0}} \right) \right] \right] \end{aligned} \right. \quad (6)$$

$$\left\{ \begin{aligned} \text{BER}_{\text{signal}} &= \frac{1}{2} \frac{1}{\log_2(NM^2)} \sum_{i=1}^M \sum_{j=1}^M \left[\{\delta_H(c_1 \rightarrow c_i) + \delta_H(c_1 \rightarrow c_j)\} \mathbb{E}_{\gamma_1} \left[\mathcal{Q} \left(\sqrt{\frac{\|\mathbf{d}_{i,j,1,1}\|^2}{4N_0}} \right) \right] \right] \\ \text{BER}_{\text{spatial}} &= \frac{1}{\log_2(NM^2)} \frac{1}{N} \sum_{k=1}^N \sum_{l=1}^N \left[\delta_H(n_k \rightarrow n_l) \mathbb{E}_{\gamma_k, \gamma_l} \left[\mathcal{Q} \left(\sqrt{\frac{\|\mathbf{d}_{1,1,k,l}\|^2}{4N_0}} \right) \right] \right] \\ \text{BER}_{\text{joint}} &= \frac{1}{N} \frac{1}{\log_2(NM^2)} \sum_{k=1}^N \sum_{\substack{l=1 \\ l \neq k}}^N \sum_{i=2}^M \sum_{j=2}^M \left[\{\delta_H(n_k \rightarrow n_l) + \delta_H(c_1 \rightarrow c_i) + \delta_H(c_1 \rightarrow c_j)\} \mathbb{E}_{\gamma_k, \gamma_l} \left[\mathcal{Q} \left(\sqrt{\frac{\|\mathbf{d}_{i,j,k,l}\|^2}{4N_0}} \right) \right] \right] \end{aligned} \right. \quad (7)$$

Here, assuming that all bit sequences transmitted through an STLC-SM packet have the equal probability, Equation (6) can be simplified to Equation (7) by considering the symmetry of the 4-QAM symbols. In other words, w.l.o.g., we consider error cases only when the APM bits are zeros.

In Equation (7), $\delta_H(c_1 \rightarrow c_p)$ and $\delta_H(n_k \rightarrow n_l)$ denote the Hamming distance of the bits transmitted through the APM and SM, respectively; $p \in \{1, 2, 3, 4\}$ and $k, l \in \mathcal{N}$. From the aforementioned 4-QAM mapping rule, $\delta_H(c_1 \rightarrow c_p)$ can be defined as $\delta_H(c_1 \rightarrow c_p) = 0$ when $p = 1$; $\delta_H(c_1 \rightarrow c_p) = 1$ when $p = 2$ or 3; $\delta_H(c_1 \rightarrow c_p) = 2$ when $p = 4$. And $\delta_H(n_k \rightarrow n_l) = \delta_H((k-1)_{(2)}, (l-1)_{(2)})$.

Also, we can calculate the Euclidean distance between the constellation $[c_1 \ n_k]$ and $[c_p \ n_l]$ regardless of N as $d_{p,k,l} = \sqrt{P} \sqrt{\gamma_k + \gamma_l + 2\sqrt{\gamma_k \gamma_l} \Theta_p(\theta_l - \theta_k)}$, where $\Theta_p(\cdot) = -\cos(\cdot)$, $\sin(\cdot)$, $-\sin(\cdot)$, and $\cos(\cdot)$, when $p = 1, 2, 3$, and 4, respectively. The general

Frobenius norm of $\mathbf{d}_{i,j,k,l} = [d_{i,k,l} \ d_{j,k,l}]^T$ in Equation (7) can then derive as $\|\mathbf{d}_{i,j,k,l}\| = \sqrt{2} \sqrt{P} \sqrt{\gamma_k + \gamma_l + \xi_{i,j,k,l} \sqrt{\gamma_k \gamma_l}}$, where $\xi_{i,j,k,l} = \Theta_i(\theta_l - \theta_k) + \Theta_j(\theta_l - \theta_k)$.

The expectation terms in Equation (7) can be derived through the following process. We first define a random variable as $Z := \sqrt{\gamma_k}$; and $\sigma \triangleq \delta^{-\alpha}$ for simplicity. Since the probability density function (PDF) of Z is given by $f_Z(z) = 2(z^3/\sigma^2) \exp(-z^2/\sigma)$, if $k = l$, its expectation is derived as follows:

$$\begin{aligned} \mathbb{E}_Z \left[\mathcal{Q} \left(\sqrt{\frac{\|\mathbf{d}_{i,j,k,l}\|^2}{4N_0}} \right) \right] &= \int_0^\infty \mathcal{Q} \left(\sqrt{\frac{\|\mathbf{d}_{i,j,k,k}\|^2}{4N_0}} \right) f_Z(z) dz \\ &= \int_0^\infty \mathcal{Q} \left(\sqrt{\frac{P}{N_0} \frac{2 + \xi_{i,j,k,k}}{2}} z \right) 2 \frac{z^3}{\sigma^2} \exp \left(-\frac{z^2}{\sigma} \right) dz \\ &= \frac{1}{2} \left[1 - \frac{(2 + \xi_{i,j,k,k} + 6/(\rho\sigma)) \sqrt{2 + \xi_{i,j,k,k}}}{(2 + \xi_{i,j,k,k} + 4/(\rho\sigma))^{3/2}} \right], \end{aligned} \quad (8)$$

where $\rho = P/N_0$ represents the transmit SNR of the TX.

Next, if $k \neq l$, it is intractable to derive the expectation terms. Thus, we use an upper bound of \mathcal{Q} -function in ref. [8], i.e. the exponential bound defined as

$$\mathcal{Q} \left(\sqrt{\frac{\|\mathbf{d}_{i,j,k,l}\|^2}{4N_0}} \right) \leq \frac{1}{2} \sum_{v=1}^V a_v \exp \left(-b_v \frac{\|\mathbf{d}_{i,j,k,l}\|^2}{8N_0} \right), \quad (9)$$

where $a_v = 2(\lambda_v - \lambda_{v-1})/\pi$; $b_v = 1/\sin^2 \lambda_v$; $\lambda_v = v\pi/2V$ for $v = 1, 2, \dots, V$; and $\lambda_0 = 0$. As V increases, the tighter exponential bound in Equation (9) is obtained.

Finally, we define two random variables as $X := \gamma_k$ and $Y := \gamma_l$. The PDFs of X and Y are then given by $f_X(x) = (x/\sigma^2) \exp(-x/\sigma)$ and $f_Y(y) = (y/\sigma^2) \exp(-y/\sigma)$, respectively. From these PDFs, the expectation terms in Equation (7) are derived as follows:

$$\begin{aligned} \mathbb{E}_{X,Y} \left[\exp \left(-b_v \frac{\|\mathbf{d}_{i,j,k,l}\|^2}{8N_0} \right) \right] &= \int_0^\infty \int_0^\infty \exp \left(-b_v \frac{\|\mathbf{d}_{i,j,k,l}\|^2}{8N_0} \right) f_X(x) f_Y(y) dx dy \\ &= \int_0^\infty \int_0^\infty \exp \left(-b_v \rho \frac{x+y + \xi_{i,j,k,l} \sqrt{xy}}{4} \right) \frac{x}{\sigma^2} e^{-\frac{x}{\sigma}} \frac{y}{\sigma^2} e^{-\frac{y}{\sigma}} dx dy \end{aligned} \quad (10)$$

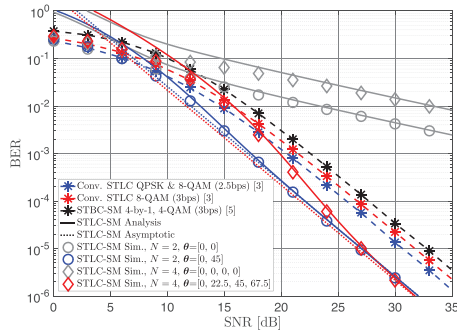

Fig. 2 BER performance of the proposed STLC-SM system when the TX is equipped with two or four antennas ($N = 2$ or $N = 4$)

$$\begin{aligned} &= \frac{1}{\sigma^4} \left[\frac{1}{A^4} + \frac{\rho^2 b_v^2 \xi_{i,j,k,l}^2}{2^5 A^6} + \frac{15\rho^2 b_v^2 \xi_{i,j,k,l}^2}{2^2 B^3} \right. \\ &+ \frac{3\rho^4 b_v^4 \xi_{i,j,k,l}^4}{2^6 A^2 B^3} - \frac{5\rho^6 b_v^6 \xi_{i,j,k,l}^6}{2^{12} A^4 B^3} + \frac{\rho^8 b_v^8 \xi_{i,j,k,l}^8}{2^{17} A^6 B^3} \\ &\left. - \left[9\rho \frac{b_v \xi_{i,j,k,l}}{B^{5/2}} + \frac{15\rho^3 b_v^3 \xi_{i,j,k,l}^3}{2^4 B^{7/2}} \right] \Phi(b_v, \xi_{i,j,k,l}, B) \right], \end{aligned}$$

where

$$\Phi(b_v, \xi_{i,j,k,l}, B) = \begin{cases} \tan^{-1} \left(\frac{4\sqrt{B}}{\rho b_v \xi_{i,j,k,l}} \right), & \text{if } \xi_{i,j,k,l} \geq 0, \\ \pi - \tan^{-1} \left(\frac{4\sqrt{B}}{\rho b_v \xi_{i,j,k,l}} \right), & \text{otherwise,} \end{cases}$$

and $A = \frac{\rho b_v}{4} + \frac{1}{\sigma}$, $B = \frac{4 - \xi_{i,j,k,l}^2}{16} \rho^2 b_v^2 + 2 \frac{\rho b_v}{\sigma} + \frac{4}{\sigma^2}$.

By substituting Equations (8), (10), and (7) into Equation (5), the closed-form of the BER upper bound of the STLC-SM system is obtained.

On the other hand, the BER upper bound (5) can be approximated as $P_b \approx 103 / (8\sigma^2 \rho^2 \log_2(NM^2))$ by using the Taylor series expansion in the high SNR regime, i.e. $\rho \rightarrow \infty$. Then, we observe that the asymptotic BER is independent of $\xi_{i,j,k,l}$. Note that the BER performance of the STLC-SM system in the high SNR regime is independent of the constellation rotation angles unless $\theta = \mathbf{0}$. Furthermore, the spatial diversity order of the STLC-SM is given by

$$\eta \triangleq -\lim_{\rho \rightarrow \infty} \frac{\log P_b}{\log \rho} \approx -\lim_{\rho \rightarrow \infty} \frac{\log \left(\frac{103}{8\sigma^2 \log_2(NM^2)} \rho^{-2} \right)}{\log \rho} = 2. \quad (11)$$

This implies that the proposed STLC-SM achieves the optimal spatial diversity order of two.

Simulation results: The BER performance of the proposed STLC-SM system and its mathematical analysis are validated through computer simulations. Figure 2 shows the BER for varying the transmit SNR when the TX is equipped with 4-QAM modulators, a single RF chain, and 2- or 4-transmit antennas, i.e. $N \in \{2, 4\}$ ¹. Furthermore, $\sigma = 1$ and we set V in Equation (9) to 50. Note that the mathematical analysis results of the BER performance of the STLC-SM are matched well with simulations. We compared the proposed STLC-SM system with the conventional single-input multiple-output (SIMO) STLC with a single RF chain at the TX under the same transmission rate [3]. For example, the SIMO STLC needs higher order modulator than the STLC-SM for satisfying the same average transmission rate as the STLC-SM (namely, 2.5 and 3 bps for $N = 2$ and 4, respectively). Furthermore, we compared the

¹From the analytical result of this letter, we observe that a near-optimal BER performance can be achieved by adjusting the rotation angle as $\theta_n = 90(n-1)/N$ when $M = 4$, and thus we set the rotation angles accordingly for all simulations.

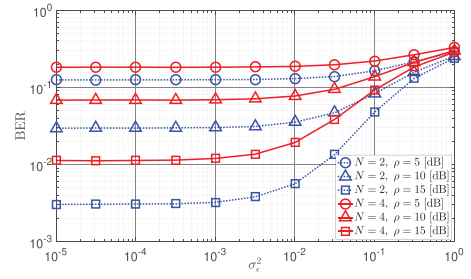

Fig. 3 BER performance of the STLC-SM in the fast fading channels

STLC-SM with the conventional STBC-SM where the CSI is assumed to be known at the RX (CSIR) [5]. For fair comparison in terms of the hardware complexity, we assume two RF chains at the TX and a single RF chain at the RX in the STBC-SM since there exist a single RF chain at the TX and two RF chains at the RX in the STLC-SM. Simulation results show that the STLC-SM without constellation rotation ($\theta_n = 0, \forall n$) is much worse than the constellation rotated STLC-SM. The STLC-SM with constellation rotation ($\theta_k \neq \theta_l, \forall k, l$) significantly outperforms the conventional SIMO STLC and STBC-SM in terms of BER performance under the same transmission rate.

Finally, we show the BER performance of the STLC-SM in the fast-fading channels in Figure 3. The effect of fast-fading is equivalently modeled as $\tilde{h}_{n,m} \triangleq h_{n,m} + \epsilon_{n,m}$, where $\tilde{h}_{n,m}$ and $h_{n,m}$ denote the current (actual) CSI and the outdated (estimated) CSI, respectively, and $\epsilon_{n,m}$ indicates the estimation error [3]. The estimation error of wireless channels is assumed to follow i.i.d. complex Gaussian distribution with a zero mean and variance of σ_ϵ^2 , i.e. $\epsilon_{n,m} \sim \mathcal{CN}(0, \sigma_\epsilon^2)$, $\forall n, m$ as in the literature. It is observed that the BER performance of the STLC-SM become gradually deteriorated as the CSI uncertainty σ_ϵ^2 increases, but it seems to be tolerant until $\sigma_\epsilon^2 = 10^{-3}$.

Conclusion: The STLC-SM scheme has been proposed, and its BER performance has been evaluated. In particular, we mathematically analysed the upper bound of the BER performance of the proposed STLC-SM system and verified it through computer simulations. It is also verified that the STLC-SM system outperforms conventional SIMO STLC system without SM in terms of the BER. It is expected that the proposed STLC-SM would be useful for low-complexity MIMO IoT networks.

Conflict of interest: The authors declare no conflict of interest.

Funding information: Institute of Information & Communications Technology Planning & Evaluation (IITP) grant funded by the Korea government (MSIT): 2019-0-00964, the National Research Foundation of Korea (NRF) grant funded by the Korea government (MSIT): NRF-2021R1A4A1032580.

© 2022 The Authors. *Electronics Letters* published by John Wiley & Sons Ltd on behalf of The Institution of Engineering and Technology.

This is an open access article under the terms of the Creative Commons Attribution License, which permits use, distribution and reproduction in any medium, provided the original work is properly cited.

Received: 16 February 2022 Accepted: 24 March 2022

doi: 10.1049/ell2.12488

References

- Mesleh, R.Y., Haas, H., Sinanovic, S., Ahn, C.W., Yun, S.: Spatial modulation. *IEEE Trans. Veh. Technol.* **57**(4), 2228–2241 (2008)
- Wen, M., Zheng, B., Kim, K.J., Renzo, M.D., Tsiftsis, T.A., Chen, K.-C., et al.: A survey on spatial modulation in emerging wireless systems: research progresses and applications. *IEEE J. Sel. Areas Commun.* **37**(9), 1949–1972 (2019)
- Joung, J.: Space-time line code. *IEEE Access* **6**, 1023–1041 (2018)
- Choi, J., Joung, J.: Generalized space-time line code with receive combining for MIMO systems. *IEEE Syst. J.* (2021)
- Başar, E., Aygölü, U., Panayirci, E., Poor, H.V.: Space-time block coded spatial modulation. *IEEE Trans. Commun.* **59**(3), 823–832 (2011)

- 6 Joung, J., Jung, B.C.: Machine learning based blind decoding for space-time line code (STLC) systems. *IEEE Trans. Veh. Technol.* **68**(5), 5154–5158 (2019)
- 7 Di Renzo, M., Hass, H.: Bit error probability of SM-MIMO over generalized fading channels. *IEEE Trans. Veh. Technol.* **61**(3), 1124–1144 (2012)
- 8 Chiani, M., Dardari, D., Simon, M.K.: New exponential bounds and approximations for the computation of error probability in fading channels. *IEEE Trans. Wireless Commun.* **2**(4), 840–845 (2003)