

Decarbonizing the food and beverages industry: A critical and systematic review of developments, sociotechnical systems and policy options

Benjamin K. Sovacool^{a,b,*}, Morgan Bazilian^c, Steve Griffiths^d, Jinsoo Kim^e, Aoife Foley^{f,g}, David Rooney^h

^a Science Policy Research Unit (SPRU), University of Sussex Business School, United Kingdom

^b Center for Energy Technologies, Department of Business Development and Technology, Aarhus University, Denmark

^c Colorado School of Mines, Colorado, USA

^d Khalifa University of Science and Technology, Abu Dhabi, United Arab Emirates

^e Department of Earth Resources and Environmental Engineering, Hanyang University, Republic of Korea

^f School of Mechanical and Aerospace Engineering, Queen's University Belfast, Belfast, BT9 5AH, United Kingdom

^g Civil, Structural, and Environmental Engineering, Trinity College Dublin, the University of Dublin, Ireland

^h School of Chemistry and Chemical Engineering, Queen's University Belfast, Belfast, BT9 5AG, United Kingdom

ARTICLE INFO

Keywords:

Climate change
Climate mitigation
Food and drinks
Industrial decarbonization
Net-zero
Energy policy
Food processing
Food manufacturing
Food systems
Sustainability transitions
Innovation

ABSTRACT

From farm to fork, food and beverage consumption can have significant negative impacts on energy consumption, water consumption, climate change, and other environmental subsystems. This paper presents a comprehensive, critical and systematic review of more than 350,000 sources of evidence, and a short list of 701 studies, on the topic of greenhouse gas emissions from the food and beverage industry. Utilizing a sociotechnical lens that examines food supply and agriculture, manufacturing, retail and distribution, and consumption and use, the review identifies the most carbon-intensive processes in the industry, as well as the corresponding energy and carbon “footprints”. It discusses multiple current and emerging options and practices for decarbonization, including 78 potentially transformative technologies. It examines the benefits to sector decarbonization—including energy and carbon savings, cost savings, and other co-benefits related to sustainability or health—as well as barriers across financial and economic, institutional and managerial, and behavioral and consumer dimensions. It lastly discusses how financing, business models, and policy can be harnessed to help overcome these barriers, and identifies a set of research gaps.

1. Introduction

The need for a more sustainable food and beverage sector is as evident as it is urgent [1,2]. On the supply side alone, the food sector via agriculture consumes roughly 200 Exajoules of energy per year [3], an amount greater than either the national energy demand of China or the United States. When including a full “farm to fork” (lifecycle) analysis that accounts for agriculture, food processing, distribution, and consumption, food production is responsible for about 30% of global energy consumption [4]. Furthermore, the food system is the largest user of land on the planet, with vineyards alone occupying about 7.5 million hectares of land, and cereals cultivated across 700 million hectares of land [5]—twice the geographic size of India. The global food industry continues to produce highly processed foods (such as readymade meals),

or sugary beverages (such as soft drinks) known for deleterious effects on public health and a resulting global burden of obesity and diabetes and their related morbidity.[6, 7, 8, 9] Greater than one-third of the food grown, procured, and processed is wasted, an unacceptable loss of resources and nutrients at a time of escalating demand for food [10]. As one study starkly summarized:

“The food and agriculture sector is central to efforts to improve public health today and protect and restore natural systems necessary to support good health in the future. The sector has a greater direct impact on land and water resources, employment, and economic activity than any other [11].”

Another report calculated that global food systems, and the food and

* Corresponding author. Science Policy Research Unit (SPRU), University of Sussex, Jubilee Building, Room 367, Falmer, East Sussex, BN1 9SL, United Kingdom.
E-mail address: B.Sovacool@sussex.ac.uk (B.K. Sovacool).

beverages industries behind them, are directly implicated in some of the most pressing sustainability challenges, contributing to 60% of biodiversity loss, 60% of land conversion, 70% of nutrient overloading, and 30% of climate change [10]. The food system also contributes to more than 50% of the eutrophication of water, a process whereby lakes and rivers receive excess nutrients and begin to collapse [12]. Due to these assorted negative costs or externalities, for every dollar spent on food, society pays two dollars in economic, social, and environmental costs—at an ultimate additional price tag of US\$5.7 trillion (in 2019) [13]. The same report estimated that by 2050, about 5 million lives could be lost annually—twice as many as the current obesity toll—as a result of unsustainable food production processes [13].

The fundamental drivers behind these unpleasant linkages between food systems, climate change, and unsustainability are manifold. The production and delivery of food necessitates a continuous and considerable supply of energy and natural resources, including not only fossil fuels but also crops, soils, biomass, plastic, steel, and minerals. One lifecycle assessment calculated that for every 1 J delivered in a final food product consumed by a household, typical energy and resource requirements needed to make and deliver that food reached about 10 J [14]. The demand for food (and its energy requirements) has grown significantly over the past few decades, in tandem with changing diets, continuing growth in human populations and the economies that help sustain them. In places such as Indonesia, the share of energy consumption in the food and beverages sector almost *doubled* between 1980 and 2015 [15].

Troublingly, developments seem to be pointing to an even less sustainable future. In Sweden, both energy consumption and energy efficiency in the food and beverage sector have been heading in the wrong direction—with consumption and emissions increasing from 2004 to 2017, and energy efficiency declining [16]. In Europe, the amount of energy to produce a ton of meat has risen substantially from 1990 to 2005 by 14%–48% [17]. In the United States, when one accounts for a fuller array of the environmental impacts of industry, the food manufacturing sector was found to be the *worst* performer and responsible for the “highest environmental impacts” including 20% of national greenhouse gas emissions and 12% of water withdrawals [18]. For comparison, the same study noted that motor vehicle manufacturing and truck manufacturing were found to be less harmful.

Moreover, the global food system is set to face unprecedented pressures over the coming decades, with challenges including competition for scarce land, water scarcity, mounting waste flows, drought, and declining crop yields and productivity due to climate change [19,20]. It is predicted that, by 2030, the growth in global population and the impacts of climate change will increase food production needs by up to 50% [21]. By 2030, the food and beverage industry will demand collectively 45% more energy and 30% more water for agriculture [22]. By 2050, the global population is expected to climb even further to 9.3 billion people with a corresponding increase in food demand by 60% [23]. For comparison, in 1960 one hectare of land was sufficient to feed 2 people, but in 2050, 1 ha of land will be needed to supply food for five people—all in a future environment prone to more constraints [22].

At this critical moment for industry and the global climate, this study focuses on this seemingly neglected area of decarbonization, and it pursues a rigorously interdisciplinary approach. It asks: What are the determinants of the food and beverage sector’s energy and carbon footprints? What options are available to decarbonize the food and beverage industry and thus make it more sustainable? What technical solutions and innovations exist to make the industry low, zero, or even net-negative carbon? What benefits will accrue from sector decarbonization, and what barriers will need to be addressed? To answer these questions, the paper undertakes a comprehensive and critical review of more than 350,000 sources of evidence, and a short list of 701 studies on the topic of food and beverage decarbonization. It also utilizes a socio-technical lens that examines food supply and agriculture, manufacturing and distribution, retail and consumption and use.

Table 1
Food product sectors, categories and sub-products.

Sectors	Products	Sub-product (example)
Alcoholic drinks	Beer	Lager
	Wine	Still red wine
	Spirits	Whiskey
Hot drinks	Flavored alcoholic beverages (FAB)	Wine-based drinks
	Coffee	Instant coffee
	Tea	Green tea
	Other drinks	Chocolate-based hot drinks
Soft drinks	Carbonates	Cola carbonates
	Fruit/vegetable juice	Nectars
	Bottled water	Carbonated bottle water
	Functional drinks	Sports drinks
	Ready-to-drink (RTD) concentrates	Powder concentrates
Packaged foods	RTD tea	Carbonated RTD tea
	Confectionery	Chocolate confectionery
	Bakery products	Breakfast cereals
	Ice cream	Take-home ice cream
	Dairy products	Yogurt
	Savory snacks	Tortilla chips
	Snack bars	Energy bars
	Meal replacement drinks	Slimming drinks
	Ready meals	Frozen ready meals
	Soup	Instant soup
	Pasta	Canned pasta
	Noodles	Instant pasta
	Canned food	Canned beans
	Frozen food	Frozen potatoes
	Dried food	Rice
Chilled food	Chilled processed meat	
Oils and fats	Olive oil	
Sauces, condiments	Soy-based sauces	
Baby food	Milk formula	
Spreads	Jams and preserves	

Source [27].

2. Background: Definitions and attributes of the food and beverage industry

Given the complexity of the topic, it is useful to first broadly define some key concepts and terms, and discuss some general facts about the structure of the global food and beverage industry or system.

2.1. Definitions and terms

The study will frequently use phrases and terms that deserve to be defined and clarified:

- The food system is the broadest concept, and it refers to the set of supply chains, social organizations, science and technology, the biophysical environment, and policies and markets dedicated to delivering food and drinks [24]. This is closest to our use of the term “sociotechnical system”, which we will return to in Section 3.
- Food manufacturing refers to all activities associated with the processing, preservation and manufacture of food, whereas drinks manufacturing refers to the manufacture of soft drinks, mineral waters and alcoholic beverages [25].
- The food and beverages industry, or FBI, most commonly refers to the combination of food and beverages manufacturing and their business supply chains [26].
- The food chain or food supply chain is similar to the notion of a system, as it comprises agricultural production, manufacturing, distribution, retail and consumption of food as well as waste disposal [21].

We refer repeatedly to a variety of “food products” in the study as

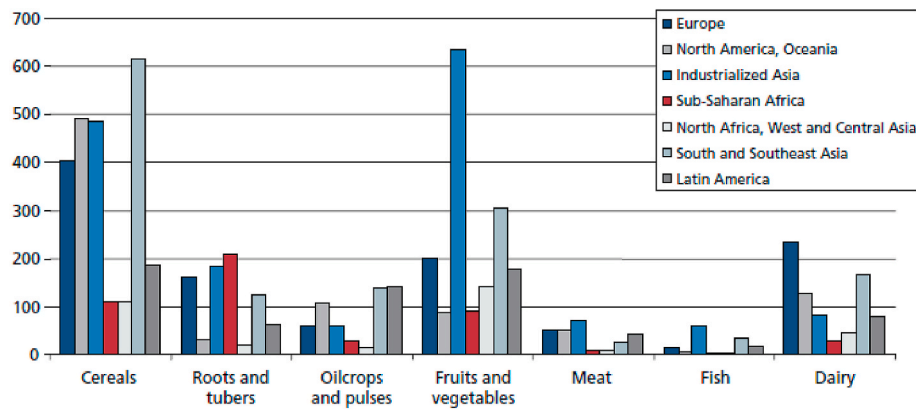

Fig. 1. Food production volumes per commodity group per region (in million metric tons). Source: [39].

well, with Table 1 offering an overview of the four most recent classifications of products as well as some of their common sub-products [27].

The food and beverage industry itself frequently discusses a “business value chain” or supply chain that is composed of three different classifications: farming (the industry involved in collecting raw commodities and converting them into staples such as rice or corn); processing (the conversion of raw commodities or staples into food); and distribution (the distribution and retail of finished or near-finished products via groceries and supermarkets or restaurants) [28].

Although the scope, coverage, and boundaries of these various terms are different, we will refer to them throughout the review. Other distinctions abound, e.g., between fresh versus processed foods, animal versus plant foods, even between fresh versus cold food chains (i.e., those that need refrigerated) [12,29], although these come up only peripherally in our review.

2.2. Industry revenues and structure

By all accounts, the global food and beverages industry is a massive and an economically critical area of activity.

To offer some context, the United States has the largest food and beverage industry and is the largest market for eating out in restaurants [30]. In the United Kingdom, the food processing industry is the largest single manufacturing sector [3], and the second largest industrial energy user, after chemicals [31]. In the United Kingdom, the food chain involves about 300,000 enterprises, employs 3.3 million people and generates 15 million tons of food each year [21]. This makes it larger than the automotive and aerospace industries combined [32]. It is also a rapidly growing sector, with its economic contribution increasing by 27% from 1997 to 2015 [33].

Across the European Union as a whole, the food and drink sector remains the largest industrial manufacturing sector as well, with annual turnover for food and drink manufacturing exceeding €1.109 trillion, and with 4.57 million employees [22,34]. Also, for household consumption across Europe, food and drink products are the second largest expenditure after housing and rent. In Sweden, food and drinks are similarly the second largest industrial sector [16]. In Galicia, Spain, food production comes second after electricity generation as the largest source of carbon emissions [35]; nationwide in Spain, the food system comes third in total energy consumption [36]. In France, perhaps due to their love of cuisine and wine, food and beverages is the largest of all industrial sectors [37].

Worldwide, in 2018 it was estimated that world consumer spending on food and beverages amounted to about USD\$7.2 trillion, or 8.6% of global Gross Domestic Product and 15.6% of all consumer spending [38]. The industry includes not only farms and sources of agriculture, but retail stores as well as food service establishments, such as restaurants and hotels, which capture about 40% of the total value of global

food sales [27].

2.3. Distinguishing attributes

Apart from its economic importance and size, four features distinguish the food and beverage industry from other sectors.

The first is very high *production volumes and distribution channels* embedded in every country, and with significant geographic scope. Using data from the Food and Agricultural Organization (FAO), Fig. 1 shows that annual production volumes for many food staples, such as cereals or fruits, surpass 500 to 600 million tons in some regions. Intricate and extensive distribution networks have arisen to funnel this food to where it needs to go. It has a “geographical spread” or reach unlike many other industries, such as automotive manufacturing or steelmaking, that are concentrated in some regions. Instead the food and beverage industry plays a “crucial role” at local and sub-regional levels as well [33]. The industry therefore involves geographically parallel sub-industries or sectors that often work side-by-side to each other, e.g. the cultivation of animal feeds and industrial crops alongside smaller scale production of oil, wine, citrus, or fruit [34].

The second is a *dualistic structure* that involves large multinational corporations alongside small and medium enterprises (SMEs). Indeed, the industry is highly fragmented with the top companies—such as Nestlé, Kraft Foods, Unilever and Cargill—accounting for less than 5% of overall economic value [28,40]. In the United Kingdom, for instance, 96% of food and drink manufacturing enterprises are SMEs [33] and in Scotland, 96% of registered businesses in the food and drink sector are small and micro employing fewer than 10 people [25]. Across Europe, 99.1% of all food and drink companies are classified as SMEs [22]. This dualistic structure means large companies must coexist alongside other smaller companies much more than in other industries [34]. The strong presence of SMEs also means the workforce has a greater proportion of “precarious employees” such as those in the medium to low income band (37% versus 24% overall) [34].

The third is the *diversity of products* offered and consumed, and consequently differential supply chains and retailers. The sector is “very heterogeneous” and must make “a highly diverse range of food and drink products.” [23] These can cut across processes such as fish processing, the raising of livestock, distilling whisky, or the manufacturing of chocolate. Each of these subsectors has different processes—including those for materials reception, mixing, separation techniques, heat processing, and waste streams—alongside supply chains and markets. As one study surmised, the “food processing industry is diverse and extensive, involving small scale, low-technology, localized operations relying on short supply lines to large, high-technology operations with complex, interconnected lines between suppliers and subsidiaries around the world.” [12] Distinct subsectors of the industry even have their own business supply chains. Take dairy, for example, which cuts

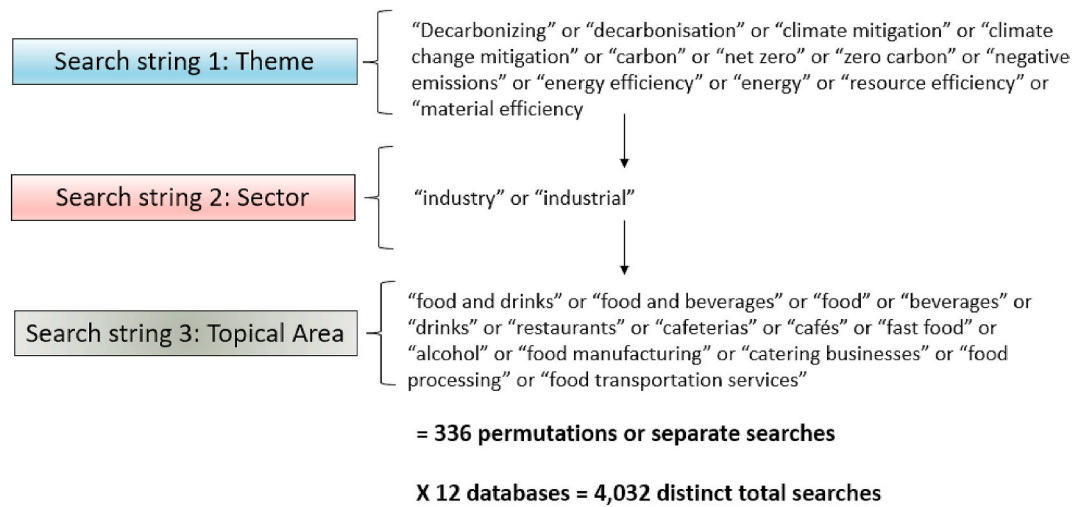

Fig. 2. Summary of critical and systematic review search terms and parameters. Source: Authors.

across raw milk and liquid milk, butter and spreads, cheese, whey products, milk powders, fermented milk, and dessert products such as milk chocolate and ice cream [41] Or the beverage packaging subsector, which cuts across oil and gas supply, bottle manufacturing, labelling and adhesives, transport, and recycling and waste management [42]. Another example would be single malt whiskey, which involves barley cultivation, yeast production, water supply, malting, distillery operation, biogas production, cask production, cork production, cardboard production, and distribution of products [43].

A fourth feature relates to the *special nature of food and drinks* themselves: they are necessary for human survival, but also must not be contaminated or polluted. Food has “special considerations” compared to other industries given that it depends on fresh and often perishable ingredients; it has direct and severe health risks associated with any inappropriate handling or production; very stringent storage and distribution requirements (often requiring the active management of hygiene or the need for refrigeration); and most food has a relatively rapid post-production shelf life [44].

These four defining features of production volumes embedded in geographic scope, dualistic structure, diversity of products and supply

chains and the need for health and safety will recur throughout our review.

3. Research design and conceptual approach: A critical, systematic, and sociotechnical review

To answer our research questions on the decarbonization of food and beverages, we utilized a critical review approach with a systematic searching protocol and the guiding conceptual lens of sociotechnical systems.

3.1. Critical and systematic review approach

We classify our review as both critical and systematic. A “critical review” seeks to demonstrate that a research team has extensively scoured the literature and critically evaluated its quality [45]. It goes merely beyond describing the literature to interpreting it and also making evaluative statements on the quality of evidence as well as possible research gaps. To do so it presents, analyzes, and synthesizes a diversity of material from a diversity of sources. A critical review offers

Table 2
Summary of critical and systematic review search results and final documents.

Database	Main topical area of database	Initial search results	Deemed relevant after screening titles, keywords and abstracts	Deemed relevant after scanning full study	Number of duplications	Total
ScienceDirect	General science, energy studies, geography, business studies	25,296	80	78	–	78
JSTOR	Social science	1096	40	9	0	9
Project Muse	Social science	884	10	2	0	2
Hein Online	Law and legal studies	1907	19	18	0	18
PubMed	Medicine and life sciences	77	7	7	3	4
SpringerLink	General science, business and area studies	18,600	79	71	1	70
Taylor & Francis Online	General science	5007	48	42	1	41
Wiley Blackwell (Wiley Online Library)	General science, area studies	1394	43	41	1	40
Sage Journals	General science, area studies	512	19	19	0	19
National Academies Publications (nap.edu)	General science	9475	25	10	0	10
Targeted internet searches	White papers, reports, grey literature (e.g., International Energy Agency, International Renewable Energy Agency, World Bank, UN agencies, and the online OECD library)	196,012	127	125	0	125
Google scholar	General science	98,400	204	200	198	2
Total		358,660	701	662	204	418

Source: Authors

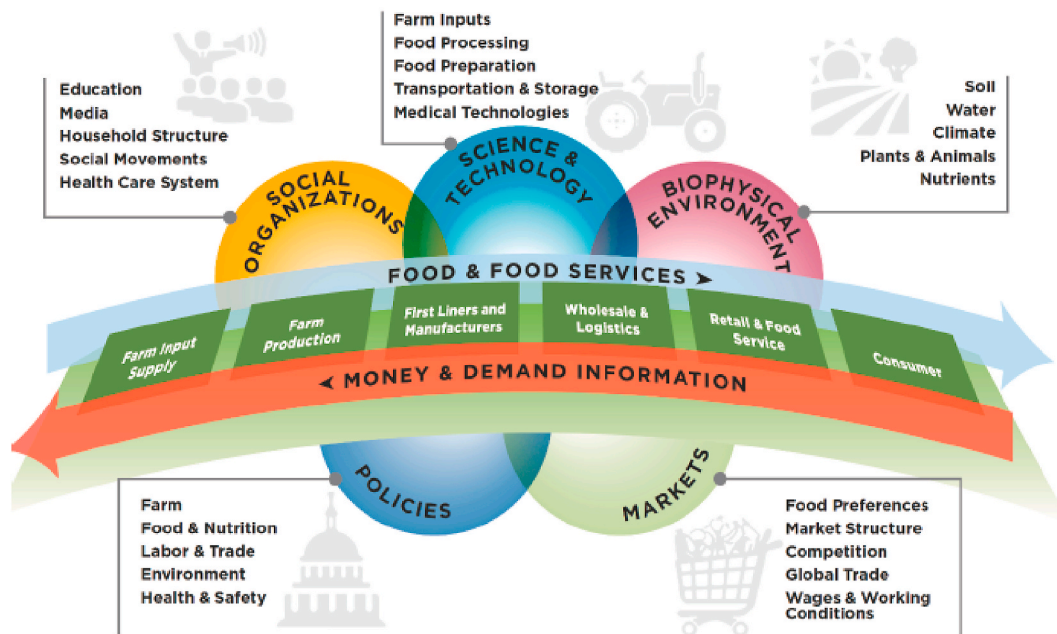
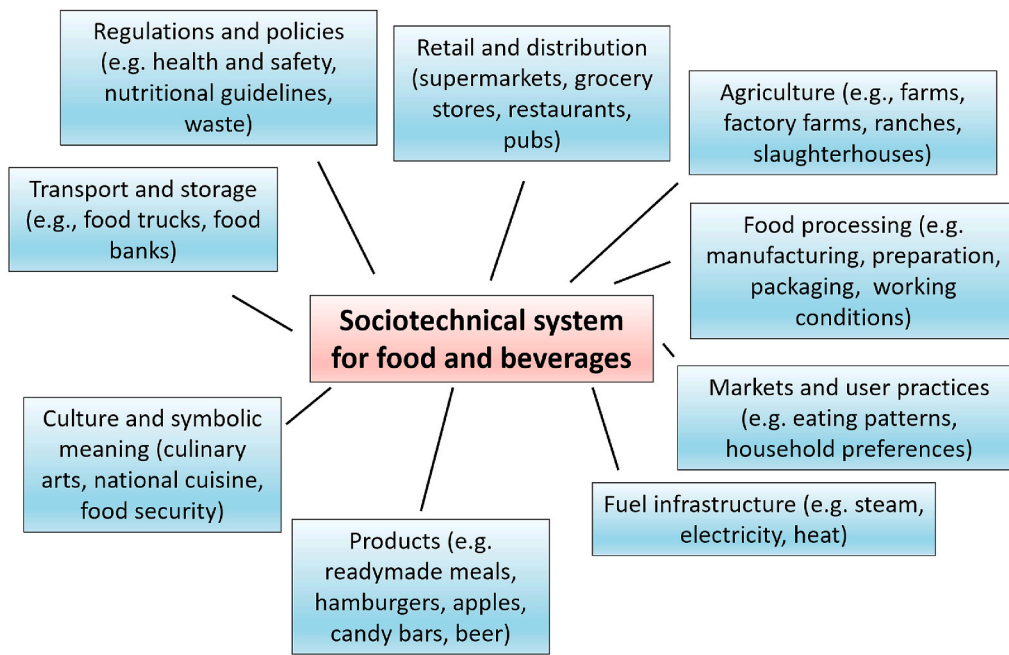

Fig. 3. Framing food and beverages as a sociotechnical system. Source: The top panel is from the authors, the bottom panel from [10] with permission.

the chance to “take stock” and evaluate what is of value within a given field, or across varying bodies of evidence, in relation to a particular topic or research question. It offers both a “launch pad” for conceptual novelty, as well as an empirical “testing” ground to judge the strength of evidence. The critical aspect of our review is most evident in Section 9 on “gaps and future research agendas.”

Given that a weakness of critical reviews is that they do not always demonstrate the systematic nature of more rigorous approaches to reviewing, we also made our review “systematic.” This approach to a review offers a number of advantages over a traditional literature review [46,47]. In particular, it has the advantage of offering:

- a focused exploration which avoids excessively wide-ranging discussion and inconclusive results;
- the avoidance of the selective and opportunistic selection of evidence;
- replicability through the documenting of study inclusion;
- the ability to discriminate between sound and unsound studies, thus assessing methodological quality; and
- increased transparency, which reduces subjectivity and bias in the reporting of results.

Systematic reviews also minimize unintentional bias (excessive self-citations or those of colleagues and friends only, e.g. “citation clubs”) and they can promote diversity, highlighting, for example, input of

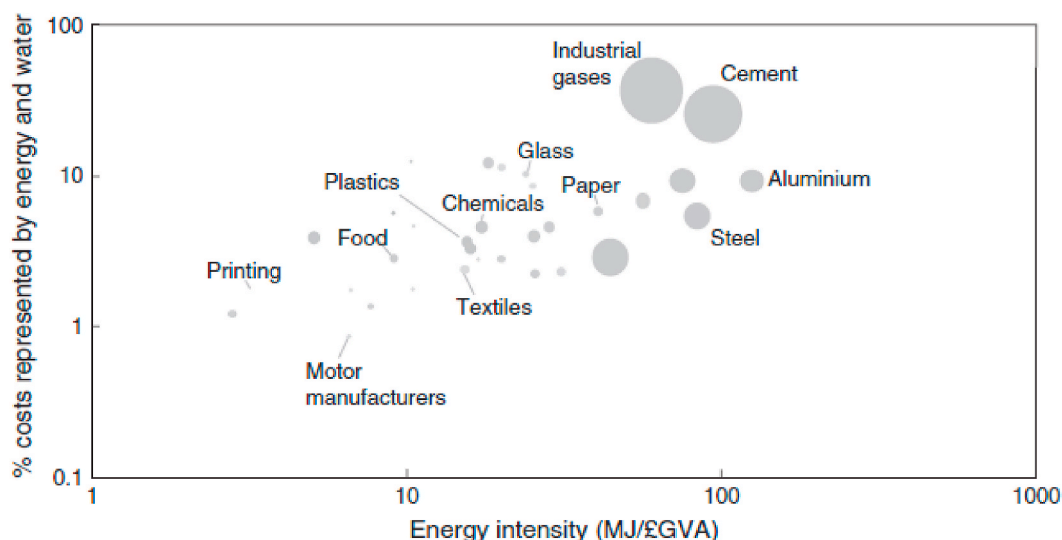

Fig. 4. Comparing energy intensities and percentage of energy and water costs for different industrial sectors in the United Kingdom. Source: [56].

studies from the Global South that are otherwise missed or excluded. For these collective reasons, multiple studies have called for greater use of systematic reviews in the domains of energy and the environment, climate change, and energy social science more broadly [48–50].

3.2. Searching protocol and analytical parameters

To guide our critical and systematic review, we relied on three distinct classes of search terms shown in Fig. 2. This resulted in 336 distinct search permutations. We then executed these search permutations—4032 search strings in total—on twelve separate databases or repositories selected to capture the state-of-the-art across both academic and policy research.

Table 2 displays our results. It notes that while our generic searches resulted in more than 358,000 potentially relevant documents, a final sample of 701 studies was most relevant. After screening them for recency (they had to be published after 2000), relevance (they had to address the specific topic of decarbonization and climate change mitigation), and originality (we adjusted the results to eliminate duplicates), this number dropped to 418 studies. We cite a majority of these studies throughout the review.

3.3. Analytical frame of sociotechnical systems

To help guide and structure our results from this corpus of 418 final documents, we utilized the analytical frame, or conceptual approach, of sociotechnical systems [51,52]. This views foods and drinks as far more than just physical products (a microwave dinner, a can of beer). Rather, the frame considers the entire set of social and technical systems involved in making, distributing, and using foods and drinks [53,54]. This includes not only hardware and infrastructure such as farms, food factories, delivery trucks, silos and barges for grain, but also social institutions such as safety and health regulations behind food, grocery stores and restaurants, and even the more prosaic set of food consuming practices or distinct cultural meanings that food attains in different societies (see top panel of Fig. 3).

The bottom panel of Fig. 3 reorganizes the sociotechnical elements of the food and beverage system by supply chain (cutting across farm supply and production to manufacturing and wholesale to retail and consumption) as well as dimension (showing the intersection of social organizations, science and technology, the environment, policies, and markets). The sociotechnical system for food and beverages thereby encompasses food production, processing, and packaging; alternative

forms of food production; food distribution; marketing and value chains; data and analytics; food waste; and food access and affordability [10]. Viewing the industry in this way is meant to uncover the fact that its sociotechnical system has become increasingly industrialized, corporatized, and mechanized in many respects [55]. But it also reveals the multiple leverage points that can be harnessed to change systematically the way the food and beverage industry functions.

Although not all studies in our sample use this rubric of a socio-technical system, we utilize it throughout the study to organize results and return to it in the conclusion. In our analysis, the different processes are grouped in a way that is comprehensive and not repetitive, but there seems to be little literature evaluating which of the different processes in a particular food system contributes most to energy consumption and carbon emissions. Even then, it is likely studies are poorly comparable because of the different boundaries for calculated carbon emissions. It thus becomes exceedingly difficult to quantify carbon emissions and energy consumption in the supply chain, such as the process of selling in the supermarket. We return to this theme in Section 9.4 with more research that grapples with the complexity and multi-scalar nature of food and beverage decarbonization pathways.

4. The energy and climate impacts of food and beverages

Our first research question relates to determining the energy and carbon footprints of the industry. As Fig. 4 indicates, in the United Kingdom the food industry sits as a moderately energy intensive industry compared to others, and also an industry with moderately high energy costs. That is, the food and beverage industry is more energy intensive than printing, and spends more on energy costs as a percentage than motor vehicle manufacturing, printing, or textiles [56]. The energy intensive aspects of the industry cut across food supply and agriculture to preparing, transporting, packaging and serving food or beverages.

4.1. Energy and carbon intensive processes in the industry

The predominant way of investigating the energy and climate impacts of the industry in the literature is to first describe the various energy intensive processes the industry depends upon.

Sticking with our sociotechnical lens, at the level of *farm input supply* and *farm production* the system has become dependent on fossil-fuel based fertilizers. Modern industrial farming is no longer based on natural energy flows and instead transforms ecosystems through the use of fertilizers, pesticides, and herbicides [57]. Livestock production and the

Table 3
Nine categories of energy intensive processes for food and drinks manufacturing.

Category	Description	Examples
Materials Reception and Preparation	The receipt, unpacking, and storage of raw materials, byproducts and waste	Conveyer belts that receive vegetables, screw conveyors for rice, or pumps for wine
	Sorting and screening	Human inspection and grading of products, de-hulling of corn, trimming of vegetable stalks, peeling
	Washing	Removing, often via sedimentation, unwanted components such as dirt, brine, salt, or microorganisms
Size reduction, mixing and forming	Thawing	Defrosting fish or meat products
	Size reduction	Cutting, chopping, slicing, mincing or pressing food materials
	Mixing and blending	Combining different materials or obtaining a more even particle size by blending
	Grinding, milling and crushing	Reducing the size of solid materials e.g. flour milling, animal feed, brewing, dairy and sugar
Separation techniques	Forming, molding and extruding	Properly shaping foodstuffs such as bread, biscuits, chocolate, pies, sausages and starch based snacks
	Extraction	Recovering soluble components from raw materials e.g. sugar from beets or sugarcane, caffeine from coffee beans, essential oils, etc.
	Centrifugation and sedimentation	Separating solids from liquids, e.g. oils and fats, cocoa butter, dairy
	Filtration	Using screens and filters to retain solids and allow liquids to pass through, e.g. beer, wine, fruit juices
Product processing technologies	Distillation	Separating liquid mixtures by partial vaporization, especially for alcohol and spirits
	Soaking	Adjusting water levels or temperature to moisten or soften grains or seeds
Heat processing	Fermentation	Utilizing microorganisms to alter the texture of foods or aid in preservation
	Pasteurization	A controlled heating process to remove microorganisms
Concentration by heat	Baking	Use of baking ovens to make food more edible
	Evaporation	Partial removal of water from a liquid by boiling
	Drying	Applying heat to remove water from liquid foods
	Freeze drying	Preserving food such as coffee extracts, spices, soup vegetables, fish and meat that cannot be dried by evaporation
Chilling and freezing	Refrigeration	Walk-in cold rooms or standalone refrigerators used to cool and store food products
	Cooling or chilling	Reducing the temperature of food from one processing temperature to another
	Freezing	Reducing the temperature of food below the freezing point, especially for pizza or ice cream
Post processing operations	Packing and filling	Placing food into wood, metal, glass, plastic, paper or cardboard packages, often in a vacuum or modified atmosphere
	Gas flushing	Storing meat, bakery products and wine in an artificially produced atmosphere
Utility processes	Cleaning and disinfecting	Removing product remnants and contaminants via cleaning in place or cleaning out of place
	Water	The movement and utilization of water for food processing, cleaning, washing, and boiling
	Vacuums	Reducing processing temperatures and extend the preservation of food
	Compressed air	Generated to run simple tools or pneumatic controls

Source: Authors modification of [60].

raising of animals for food requires the conversion of land and are thus connected to colossal changes in land use. The livestock sector accounts for 18% of global greenhouse emissions, and 80% of anthropogenic land use [58]. Animal agriculture produces more than 100 million tons of methane a year, and a single cow produces about 80–110 kg of methane over the same period, not including methane released from manure [59]. Significant emissions are also released from the lagoons used to store untreated farm and animal waste. When put together, the carbon equivalent emissions from livestock are *greater* than the emissions from all passenger vehicles in the world. Additionally, the manure lagoons at many animal processing facilities release toxic gases and contaminate water [55]. Although one study projected at least 200 EJ of energy consumption for agriculture and farming, it noted almost half of this (45%) related to only two aspects - processing/manufacturing and distribution/transport [3].

At the level of *food manufacturing and processing*, one study noted, “the food and drink industry is a major user of energy in a large number of diverse applications, which include the provision of steam or hot water, drying, other separation processes such as evaporation and distillation, refrigeration, and baking.” [26] One survey of this part of the industry noted more than forty energy intensive *processes* [14]:

- Material handling and storage,
- Germination,
- Sorting/screening,
- Smoking,
- Peeling,
- Hardening,

- Washing and thawing,
- Carbonation,
- Cutting/slicing/chopping,
- Melting,
- Mixing/blending,
- Blanching,
- Grinding/milling/crushing,
- Cooking and boiling,
- Forming/molding/extruding,
- Baking,
- Extraction,
- Roasting,
- Centrifugation sedimentation,
- Frying,
- Filtration,
- Tempering,
- Membrane separation,
- Pasteurization,
- Crystallization,
- Evaporation,
- Removal of fatty acids,
- Drying,
- Bleaching,
- Dehydration,
- Deodorization,
- Cooling and chilling,
- Decolorization,
- Freezing,

- Distillation,
- Freeze-drying,
- Dissolving,
- Packing and filling,
- Solubilization/alkalizing,
- Cleaning and disinfection,
- Fermentation,
- Refrigeration,
- Coagulation,
- Compressed air generation.

When applied to particular food and drinks industry subsectors, one can also classify such processes according to the nine core categories in Table 3: materials reception and preparation; size reduction, mixing and forming; separation techniques; product processing technologies; heat processing; concentration by heat; chilling and freezing; post-processing operations; and utility processes [60].

Of particular note is that particular processes are more energy consuming than others. For instance, one of these nine categories, chilling and freezing, uses a monumental amount of energy. It has been estimated that although only 40% of foods require refrigeration, refrigerators and freezers consume roughly 15% of global electricity [61]. Among food and drink processing activities, energy and related greenhouse gas emissions are very heterogeneous. Food canning is very steam intensive, with boilers using 70% of the activity energy; baking requires large ovens using 60% of the activity energy; frozen and chilled foods have large refrigeration loads using 60% of the activity energy; and flour milling plants have large electrical loads using 80% of the activity energy [60].

At the level of retail and distribution, supermarkets, hypermarkets, grocery stores, and restaurants all utilize energy in various ways as they preserve, market, and sell food. This can include not only refrigeration to extend product lifetimes, but also interior and exterior lighting, heating and cooling (especially air conditioning), and in-house baking, cooking, and food preparation [21]. For supermarkets in particular, energy consumption will vary by store format, business and operational practices, mix of products, shopping activities and equipment utilized to prepare or display food. Thus, their electricity consumption can differ greatly from about 700 kWh/m² sales area in hypermarkets to over 2000 kWh/m² sales area in convenience stores [62]. Refrigeration systems account for by far the most energy consumption (between 30% and 60% of the electricity used), whereas lighting accounts for between 15% and 25% [62]. HVAC equipment and other utilities accounting for the remainder. Gas is normally used for space heating, domestic hot water and in some cases for cooking and baking and will vary from 0 kWh/m² in small stores, such as petrol filling stations where gas is not used, to

over 250 kWh/m² in hypermarkets. In some stores the gas energy consumption can be as high as 800 kWh/m² [62].

At the level of transport and delivery, food now travels more than it did in 1980; with the average bite most people eat travelling 1500 to 2500 miles (2414 to 4023 km) to reach their mouths [58]. Even locally grown food is often shipped from a nearby farm to be washed and packaged somewhere else, then transported back home. One study looking at cans of strawberry yogurt produced in Germany found that the average carton involved 8000 km (4970 miles) of roads for production and distribution [63]. Another study reveals estimated Canadian import “food miles” to be more than 61 billion ton-km, resulting in 3.3 million Mt CO₂ annual emissions [64]. In the United Kingdom, it has been estimated that food consumed there for one year required 30 billion vehicle kilometers [17]. An intricate array of sea, land, and air transport systems deliver these food miles, with a fleet of approximately 1300 specialized refrigerated cargo ships, 80,000 railcars with refrigeration, 650,000 refrigerated containers and 1.2 million refrigerated trucks [17]. Airplanes and air-freighting is becoming a more popular mode of transport as well, especially for perishable products of high value such as strawberries, live lobsters and asparagus. Moreover, given that most food transport requires refrigeration, up to 40% of diesel consumed during transport can be used by refrigeration systems [17]. This could be why freight transport consumes nearly 25% of all the petroleum worldwide and produces over 10% of carbon emissions from fossil fuels [17]. Fig. 5 reveals estimated energy consumption with different food transport vehicles. The globalized food and beverage system does respond to business and consumer choices, but it is obvious that transportation increasingly contributes to greenhouse gases.

At the level of consumption and use, there are substantial energy and climate implications for cooking, even within households. This includes not only the direct usage of wood/biomass, gas, or electricity to heat and prepare meals, but also indirect land use changes with fuelwood collection and the emissions of black carbon (referred to by scientists as “carbonaceous aerosols” and commonly referred to as “soot”). Since billions of individuals rely on biomass for cooking and heating, about two million tons of it is combusted every day [65]. The Food and Agriculture Organization has calculated that wood-fuel collection accounts for almost half of all wood harvested from the world’s forests and plantations each year [66], something that accelerates global tropical deforestation [67]. Reliance on biomass fuels and coal for cooking and heating is responsible for about 10–15% of global energy use, making it a substantial source of greenhouse gas emissions. One study, for example, projected that by 2050, the smoke from wood fires will release about the same amount of carbon dioxide as the entire United States [68]. Finally, cooking and heating fires are a major source of black carbon, an extremely potent contributor to climate change that results

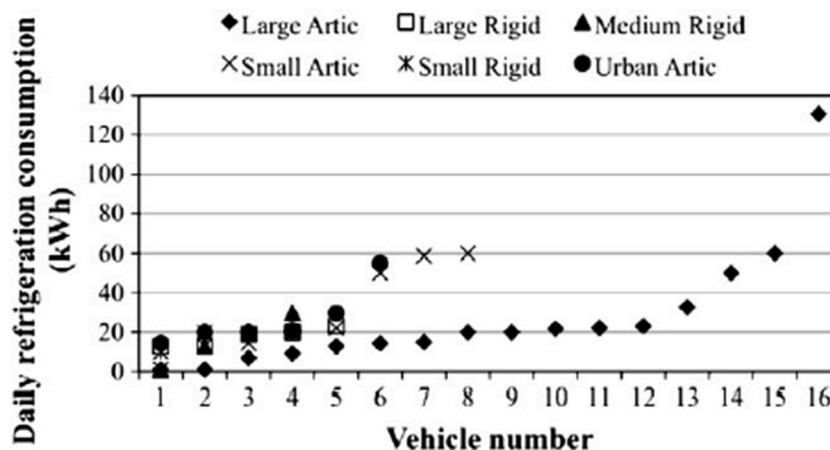
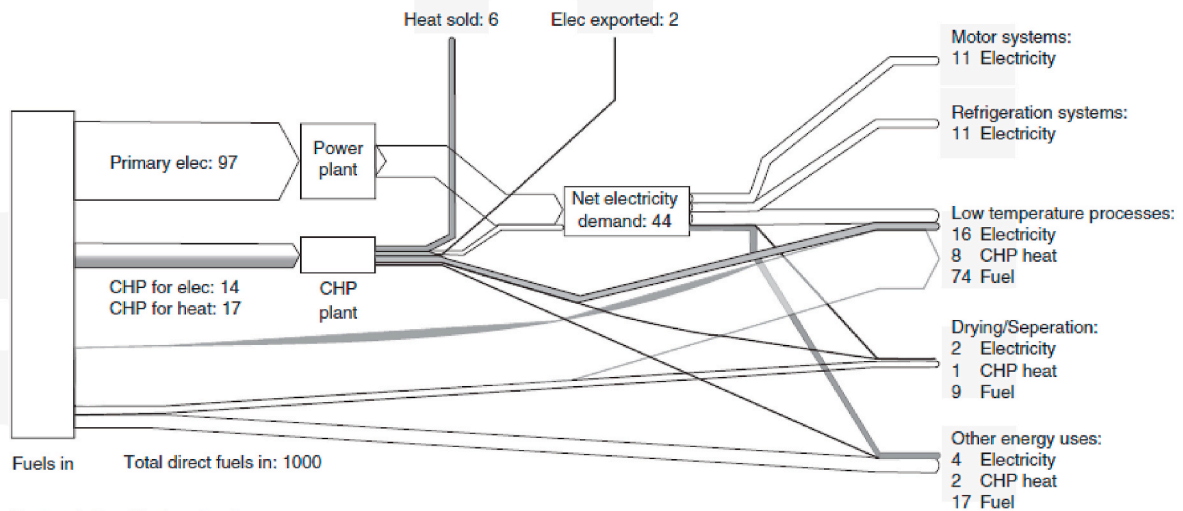

Fig. 5. Estimated energy consumption of food delivery refrigeration systems in the United Kingdom. Source: [17]. Vehicles range from small to large configured in urban and rural delivery schedules, accounting for the variance in consumption.

A)



Vast majority of fuels natural gas
 Distribution losses associated with fossil fuels not included
 Conversion and distribution losses associated with power and CHP plant not shown.
 All flows in PJ.
 Flows less than 0.5PJ omitted, flows rounded to nearest PJ

B)

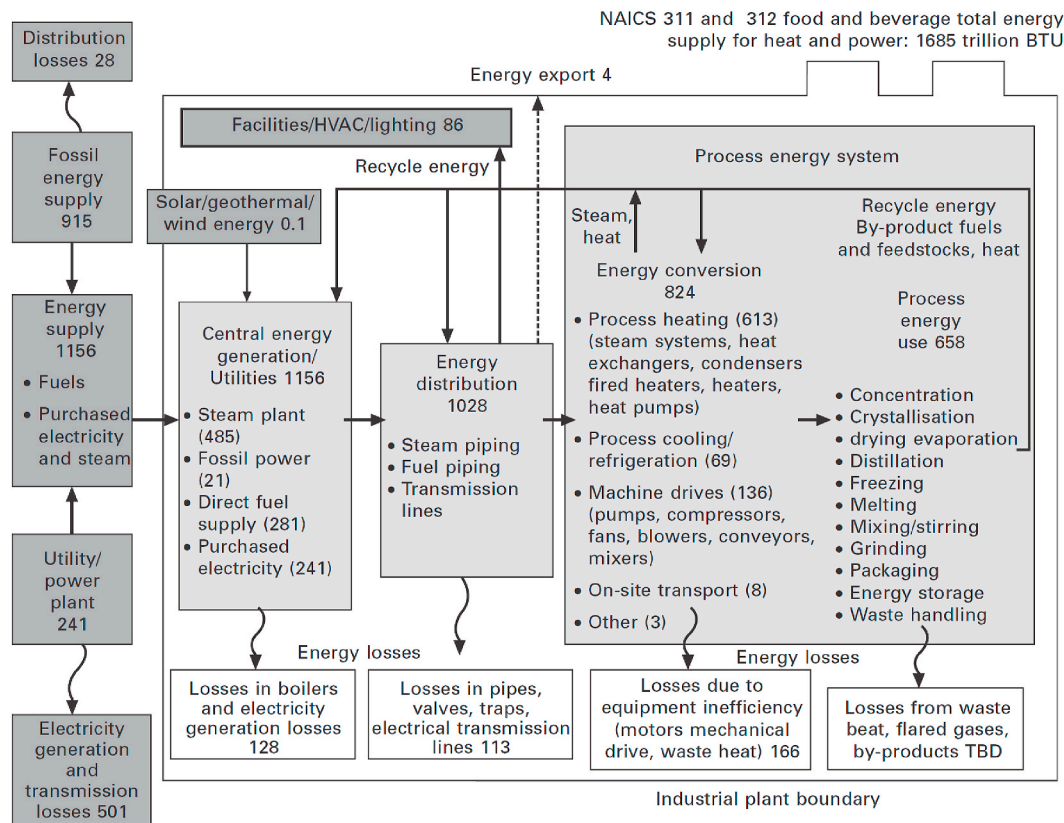

Fig. 6. Mapping energy and heat flows for the food and drink industry in the United Kingdom (in Petajoules), top panel A; United States (in trillion BTUs) middle panel B; and Canada (as a %, bottom panel C). Source: [26,56]. Note CHP = combined heat and power. HVAC = heating, ventilation and air conditioning. TBD = losses from total blowdown from boilers and generators. NAICS = North American Industry Classification System. FBI = food and beverage industry. BTU = British Thermal Unit. One BTU = approximately 1055.06 Joules or 0.2931 Wh.

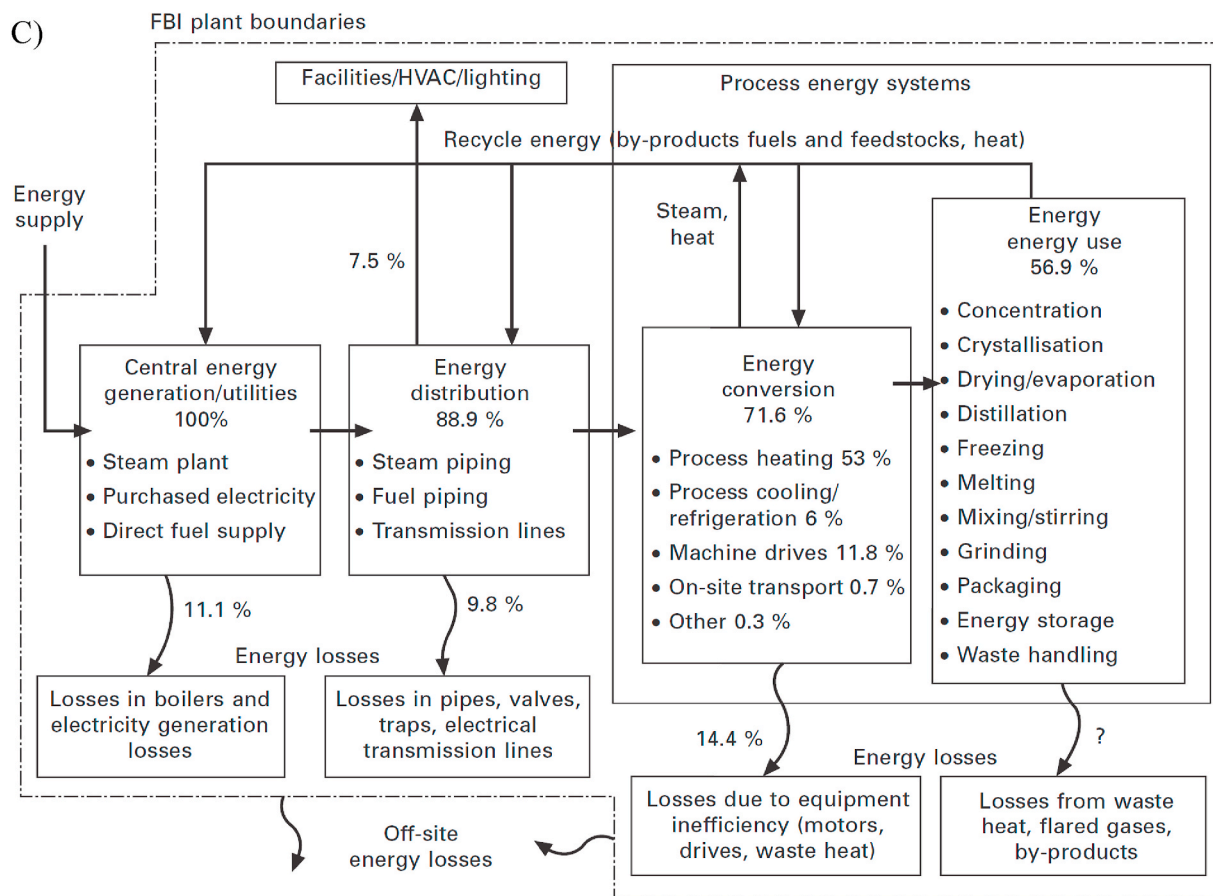

Fig. 6. (continued).

from the incomplete combustion of coal and wood [69]. Notable differences in energy consumption also emerge between types of countries, with 48% of energy consumption in developed countries used for food processing and distribution, whereas in developing countries 43% is used for food preparation and cooking [29].

4.2. Attributes of heat, energy and power demand

Given the complexities described in 4.1, credible estimations of the specific energy, heat and electricity consumption profiles for the industry are time consuming and rigorous to produce. Most studies look only narrowly at one specific level of the system (e.g., food manufacturing) and a specific area (e.g. the United Kingdom). For instance, in the United Kingdom it has been estimated that the food

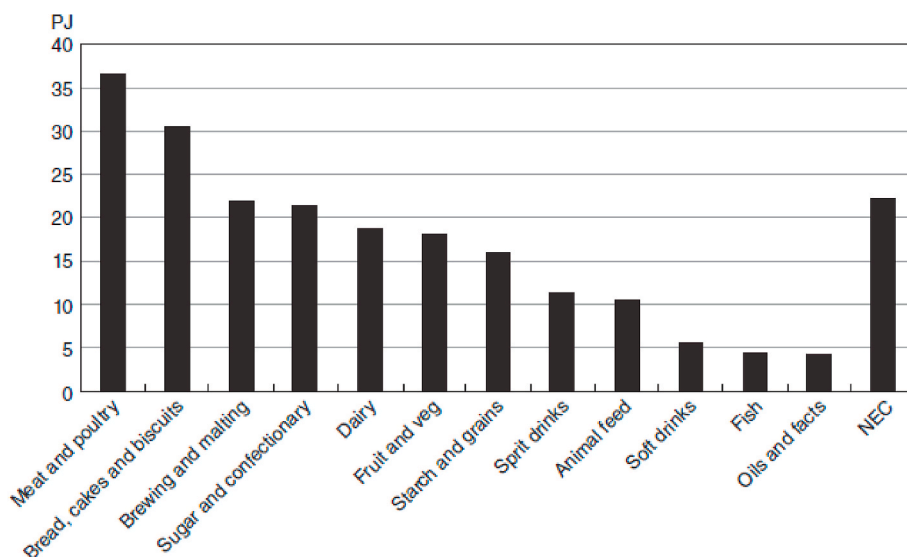

Fig. 7. Primary energy demand for food and drink subsectors in the United Kingdom. Source: [56]. Note: NEC = not elsewhere classified.

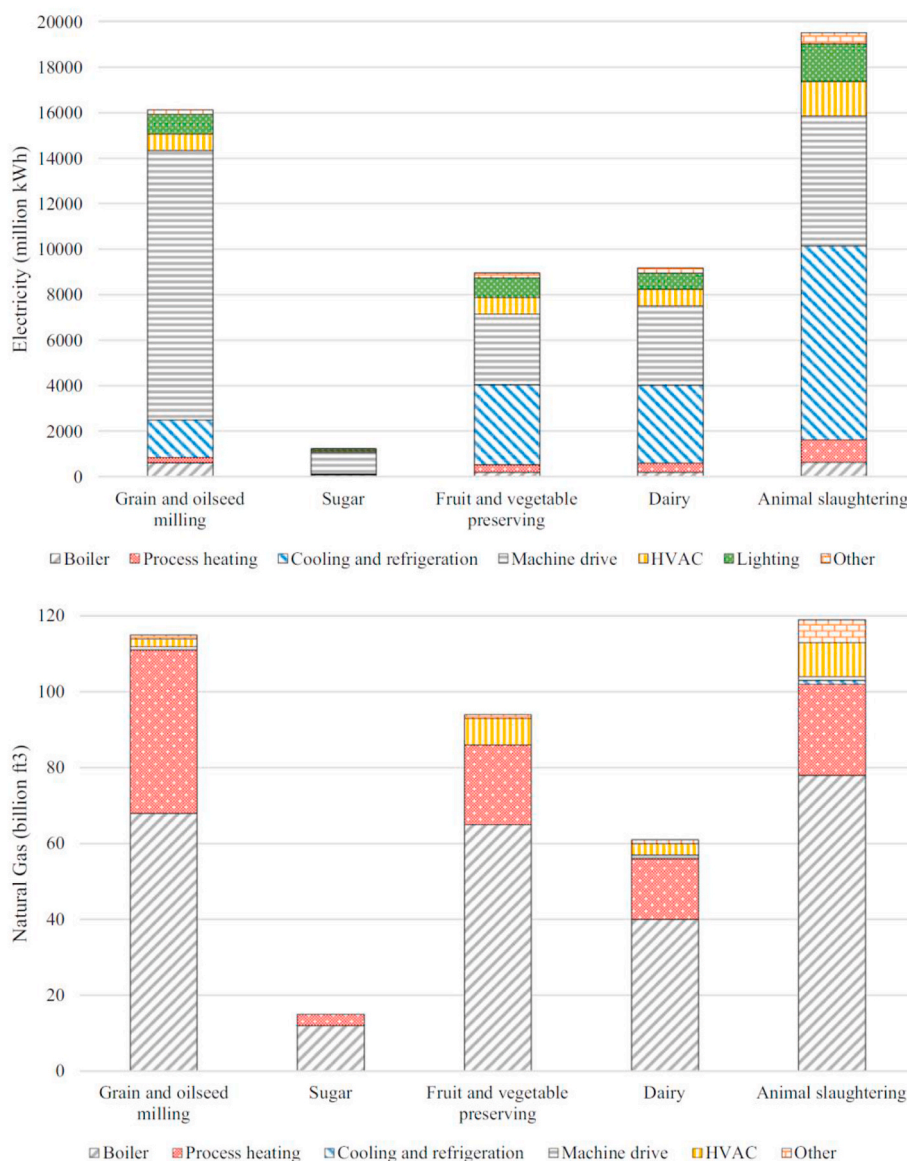

Fig. 8. Electricity and natural gas consumption by food processing subsector in the United States. Note: one cubic foot = 0.028 cubic meters. Source: [70].

processing industry consumes 68% of its energy in fuel-fired boilers and direct heating systems, followed by 16% for electric motors, 8% for electric heating, and 6% for refrigeration and air compressors [21]. The fuel use for the sector is dominated by natural gas (almost two-thirds) followed by electricity with then a minor amount of oil and coal making up the remainder [60]. When looking at the UK food processing sector by process, it was the high heat demand for drying, evaporation, baking ovens, pasteurization, kilning, and steam production that had the largest consumption, and it was refrigeration and cooling that had the largest electricity consumption [60]. Fig. 6 attempts to capture the energy flows throughout the entire sector for three countries, including in the UK (see Panel A), which was estimated to use 1000 Petajoules of fuel each year.

The food processing industry in the United States consumes about 8% of all nationwide energy, most of which comes from electricity and natural gas [70]. Energy flows are broken down for the food processing industry for heat and power in panel B of Fig. 6. There, it is estimated that food and beverage processing utilizes approximately 1685 trillion British Thermal Units (BTUs) [26], or about 493.8 TWh. The energy supply chain starts with fuels such as electricity, steam, gas and coal that are supplied to food plants from offsite. These fuels are converted into

Table 4

The thermal and electrical energy required per ton of produced product across six European countries.

Branch/product	Thermal energy (kWh/t)	Electrical energy (kWh/t)
Bakeries	1335 (243–3039)	590 (150–1834)
Beverages	317 (56–1950)	253 (14–800)
Dairy	1055 (129–3957)	625 (21–3636)
Fruits and vegetables	459 (124–1235)	253 (85–1235)
Meat	510 (20–1668)	354 (77–957)
Beer	373 (0–1950)	219 (52–800)
Sugar	1759 (1398–3076)	282 (185–560)
Slaughtering	155 (0–343)	326 (77–953)
Meat Processing	612 (20–1668)	366 (85–957)

Note: kWh = kilowatt-hour. t = metric ton. The six countries are Austria, France, Germany, Poland, Spain, and the United Kingdom. Source [71]

usable energy via an onsite source of energy supply or immediately distributed for direct use by plant equipment. For the United States, the bulk of this (613 trillion BTUs, or 179.6 TWh) go for processing heating followed by machine drives and pumps (136 trillion BTUs, 39.9 TWh) and then process cooling and refrigeration (69 trillion BTUs, or about 2

Table 5
Embodied energy use for different food products across sectors.

Product	Specific electricity consumption	Specific fuels and heat consumption	Unit
<i>Meat sector</i>			
Pig and pork	465	932	MJ/t dress carcass weight
Beef and sheep	341	537	MJ/t dress carcass weight
			ight
Poultry	1008	576	MJ/t dress carcass weight
Processed meat	750	3950	MJ/t product
Rendering	234	1042	MJ/t raw material
<i>Fish sector</i>			
Fresh fillets	129	6	MJ/t product
Frozen fish	608	6	MJ/t product
Prepared and preserved fish	482	1062	MJ/t product
Smoked and dried fish	12	2077	MJ/t product
Fish meal	684	6200	MJ/t product
<i>Fruits and vegetables sector</i>			
Potato product	5722		MJ/t product
Un-concentrated juice	250	900	MJ/t product
Tomato juice	125	4789	MJ/t product
Frozen vegetables and fruits	738	1800	MJ/t product
Preserved mushrooms	2898		MJ/t product
Vegetables preserved by vinegar	2178		MJ/t product
Tomato ketchup	380	1700	MJ/t product
Jams and marmalade	490	1500	MJ/t product
Dried vegetables and fruits	1500	4500	MJ/t product
Crude and refined oil	672		MJ/t product
<i>Dairy products</i>			
Milk and fermented products	241	524	MJ/t product
Butter	457	1285	MJ/t product
Milk powder	1051	9385	MJ/t product
Condensed milk	295	1936	MJ/t product
Cheese	1206	2113	MJ/t product
Casein and lactose	918	4120	MJ/t product
Whey powder	1138	9870	MJ/t product
<i>Starch and starch products</i>			
Wheat starch	2960	8800	MJ/t product
Maize starch	1000	2331	MJ/t product
Potato starch	1425	3564	MJ/t product
<i>Prepared animal feeds</i>			
For farm animals	475		MJ/t product
For pets	2306		MJ/t product
<i>Sugar</i>			
Refined sugar	555	5320	MJ/t product
Beet pulp	5	1820	MJ/t product
<i>Other products</i>			
Sweet biscuits	4581		MJ/t product
Waffles and wafers	3195		MJ/t product
Soup and broths	7659		MJ/t product
Pasta	648	2	MJ/t product
Flour	420	30	MJ/t product
Cacao beans	6384		MJ/t product
Non-roasted coffee	141	1597	MJ/t product
Roasted coffee	518	1997	MJ/t product
Extracts of coffee solid form	15,675		MJ/t product
Beer	19.5	153	MJ/hl product
Mineral water and soft drinks	133	199	MJ/1000 l product
Unsweetened water drinks and soft	120	360	MJ/1000 l product

Note: MJ = Megajoules. t = metric tons. l = liter.

Source [72]

TWh). Substantial losses occur throughout the system, a point we will return to later when discussing energy management and energy efficiency efforts as optimal solutions.

A similar energy map has been produced for the food and beverages industry in Canada in Panel C of Fig. 6. Canada is estimated to have a much smaller energy consumption footprint than the United States, consuming only 98 Petajoules of energy used by the manufacturing sector. In Canada, a different fuel mix of natural gas and petroleum derivatives provide most of the energy, followed to a smaller extent by electricity.

Other studies take a sectoral approach that calculates and examines energy consumption profiles across subsectors such as baking, dairy, or meat production. Fig. 7 shows this approach when applied to the United

Kingdom, and it suggests that the most energy intensive subsectors are meat and poultry and baking breads and biscuits, with the least energy intensive being soft drinks, fish, and oil and fats [56].

In the United States, similar analyses have been done on the energy consumption profiles of subsectors, with greater nuance given between electricity consumption (top panel of Fig. 8) and gas consumption (bottom panel of Fig. 8). There, animal slaughtering and grain and oilseed milling account for the largest sources of electricity consumption and natural gas consumption. Other approaches within the literature may focus on the thermal or electrical energy required to make a ton of a product within a sector (see Table 4, which looks at six European countries) [71].

Still other studies employ a product approach that calculates the

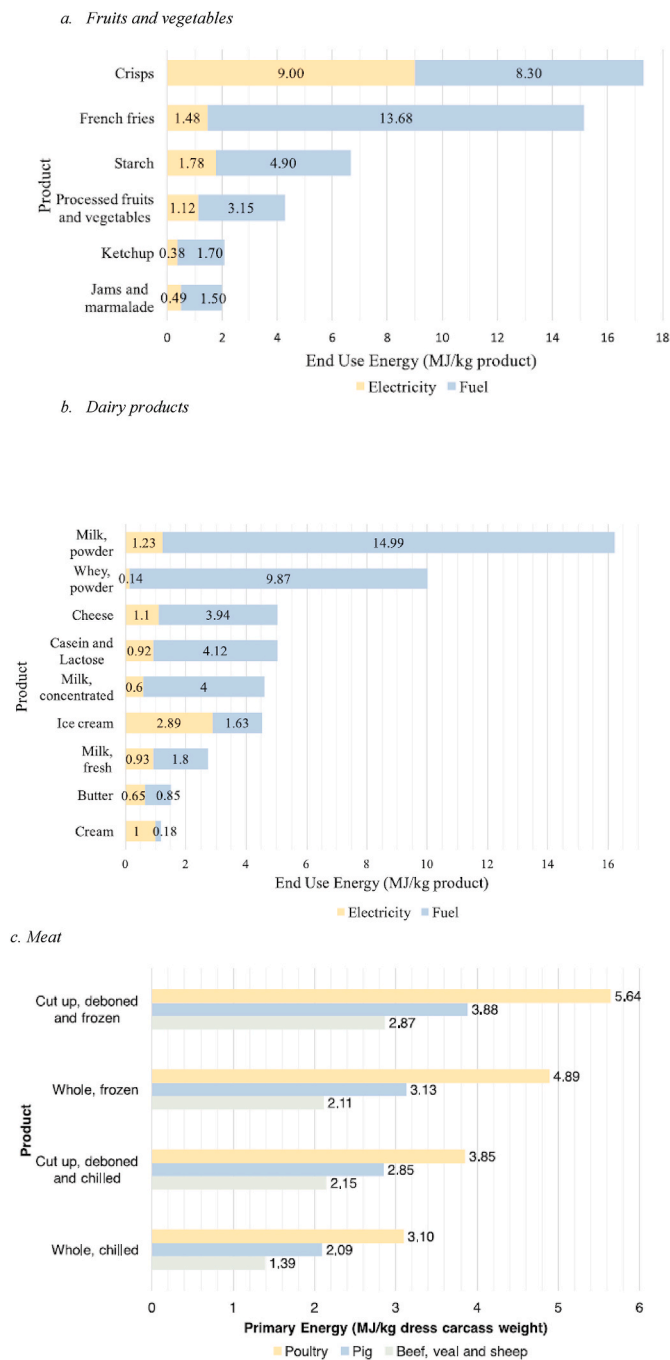

Fig. 9. Embodied energy needed to process and manufacture various food products. Source: [3]. Note: MJ = Megajoule. kg = kilogram.

energy required to manufacture and use a very particular item such as processed meat, jams, ketchup or dried fruit. Table 5 summarizes these calculations across the meat, fish, fruit and vegetable, dairy, and other sectors. Other research attempts to calculate the actual total energy use (including electricity, fuel, thermal and steam energy) associated with different food products, reflecting the embodied energy needed to manufacture diverse products. Fig. 9 depicts these results for actual food in the United Kingdom.

4.3. Estimations of greenhouse gas emissions

Estimations of greenhouse gas emissions and carbon footprints follow a similar approach to those for energy, given the two are linked.

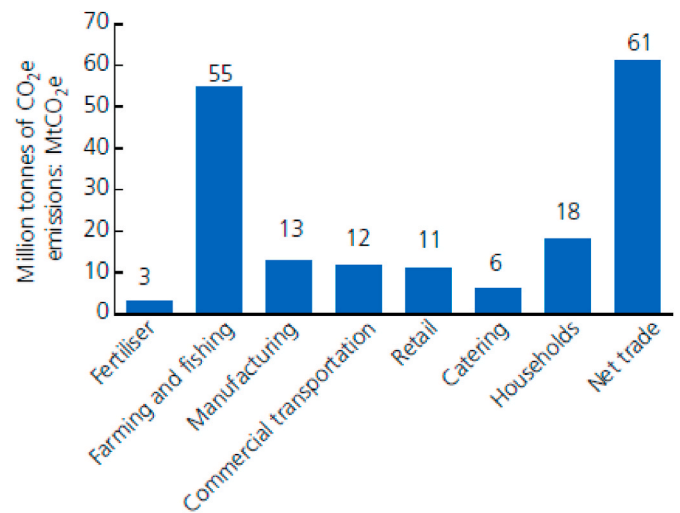

Fig. 10. Greenhouse gas emissions from the food sociotechnical system in the United Kingdom. Source: [21].

Table 6

Carbon emissions associated with transporting food from its source to stores and homes in the United Kingdom.

Transport mode	CO ₂ emissions as a proportion of total food transport emissions (%)	Transportation (ton-km) as a proportion of total transportation (%)
UK road (total commercial)	39	35
UK road HGV	33	19
UK road private cars	13	48
Overseas road HGV	12	7
International by sea	12	0.04
International HGV	12	5
International air freight	11	0.1
UK road LGV	6	16
Overseas road LGV	2	5
Rail, inland waterways	Insignificant	Insignificant

Note: HGV = Heavy-Goods Vehicles. LGV = Light (Local) Delivery Vehicles. Source [17]

But carbon footprints are not always commensurate to energy consumption profiles for one key difference: the food and beverage industry actively uses, and processes, carbon dioxide alongside whatever carbon flows arise from energy, heat, and steam. The industry uses carbon dioxide for example as an “increasingly popular refrigerant.” [73] Carbon is also directly used to carbonize beverages, to produce deoxygenated water, to undertake casein precipitation, to pretreat olives, to serve as an acidifier, and to enhance the shelf life of some fruits and vegetables [74]. Methane and short lived greenhouse gas emissions from farming and dairy stockbreeding are considerable. So carbon footprints are differentiated from energy footprints in meaningful ways. Here, the literature offers five different types of assessments.

Some studies focus on estimating carbon footprints by country and/or sector. It is estimated, for example, that food purchases accounted for about 16% of greenhouse gas emissions in the United States, most of them (more than two-thirds) coming from the agriculture and food manufacturing stages [75]. Fig. 10 shows a similar assessment of national emissions across food subsectors for the United Kingdom, with farming and fishing (55 million tons) and trade (61 million tons)

Table 7
Estimated carbon intensity for various food products.

Food product	Carbon intensity (in kg CO ₂ e per dollar)
Beef, pork, and other red meat	2.58
Cheese	2.01
Fluid milk, milk products, and butter	1.88
Flours and rice	1.79
Dry, condensed, and evaporated dairy	1.77
Eggs	1.21
Frozen foods	1.02
Ice cream and frozen desserts	1.00
Poultry	0.98
Fats and oils	0.92
All other foods	0.83
Canned foods	0.80
Sugar and confectionery products	0.77
Seasonings and dressings	0.77
Cookies, crackers, pasta, and tortillas	0.76
Fresh vegetables and melons	0.73
Breakfast cereal	0.67
Snack foods	0.62
Soft drinks, bottled water, and ice	0.62
Bread and bakery products	0.61
Breweries	0.59
Seafood	0.57
Coffee and tea	0.57
Fruits and tree nuts	0.54
Wineries	0.37
Distilleries	0.34

Source [75].

accounting for the greatest levels of emissions [21].

Other studies breakdown carbon emissions by process. In the United Kingdom, it is estimated that steam and hot water provision account for the largest single share of sector emissions at 37%. This is followed by cooling and freezing (17%), fans and pumps (12%), and lighting and electrical motors (9%) [60].

A third approach has been to examine the particular carbon footprints for elements of the food system such as packaging. It has been determined that carbon and plastic drink packaging (including high-density polyethylene containers) have lower carbon footprints than aluminum, steel, and glass containers. However, after recycling the

carbon footprints for glass, aluminum, and steel improve considerably [42].

A fourth set of literature focuses on the transport related emissions with food delivery and distribution. This literature suggests that in the United States, transportation by trucks has the worst carbon intensity (the greatest emissions) followed by water transport and air [75]. In the United Kingdom, air is the most energy and carbon intensive form of food delivery, accounting for less than 1% of all food consumed in the country but about 11% of the total food carbon footprint; 1.5% of fruit and vegetables are carried by air but these represent 40% of the total carbon footprint used in the transport of vegetables [17]. Table 6 shows transport emissions from food delivery for the United Kingdom as a whole. Reliance on diesel-powered refrigeration equipment creates a large carbon footprint, increasing the level of emissions per ton of product delivered. Yet unlike truck tractor units, refrigeration motors on “reefer” trailers continue to be less regulated and release high levels of noxious emissions. Globally, estimates suggest that the same amount of fuel can transport 5 kg of food only 1 km by personal car, 43 km by air, 740 km by truck, 2400 km by rail, and 3800 km by ship; this body of work also suggests that refrigeration accounts for about 40% of the total energy requirements used during this transport and distribution [17].

The fifth and most extensively utilized approach is to calculate the carbon footprints of particular food products. Energy consumption profiles suggest that a relatively small number of products are responsible for 80% of the carbon emissions within the UK food chain, the most significant of these are the making of bread and fresh pastry goods, production of cheese and other dairy products, production of meat and poultry products, and manufacture of beer and alcoholic beverages [21]. Chocolates are particularly carbon intensive, given that they need milk powder, cocoa derivatives, sugar and palm oil [76]. Table 7 shows the estimated carbon equivalent emissions associated with different food products for the United States.

Still other studies calculate the carbon footprint for particular meals, especially readymade meals such as roast dinners, cottage pies, and lamb curries – with roast pork apparently having the lowest carbon footprint, and spaghetti Bolognese having the highest carbon footprint [77]. Such readymade meals can add up to significant carbon impacts—in the United Kingdom, it is estimated that the carbon emissions from readymade meals are almost 13 million tons of carbon

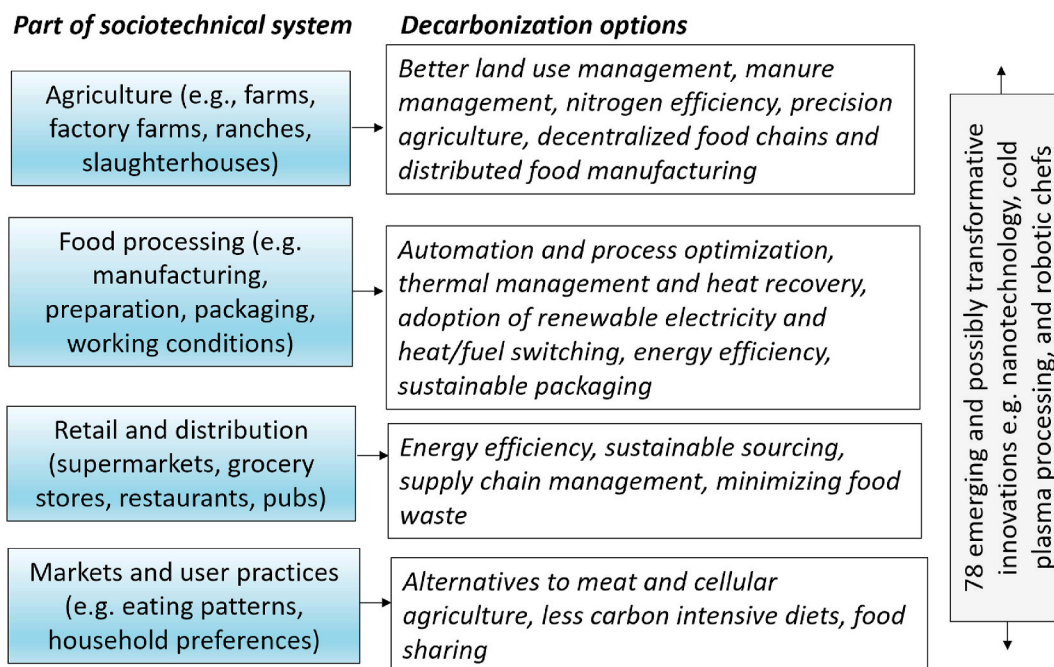

Fig. 11. Sociotechnical options for decarbonizing the food and beverage system.

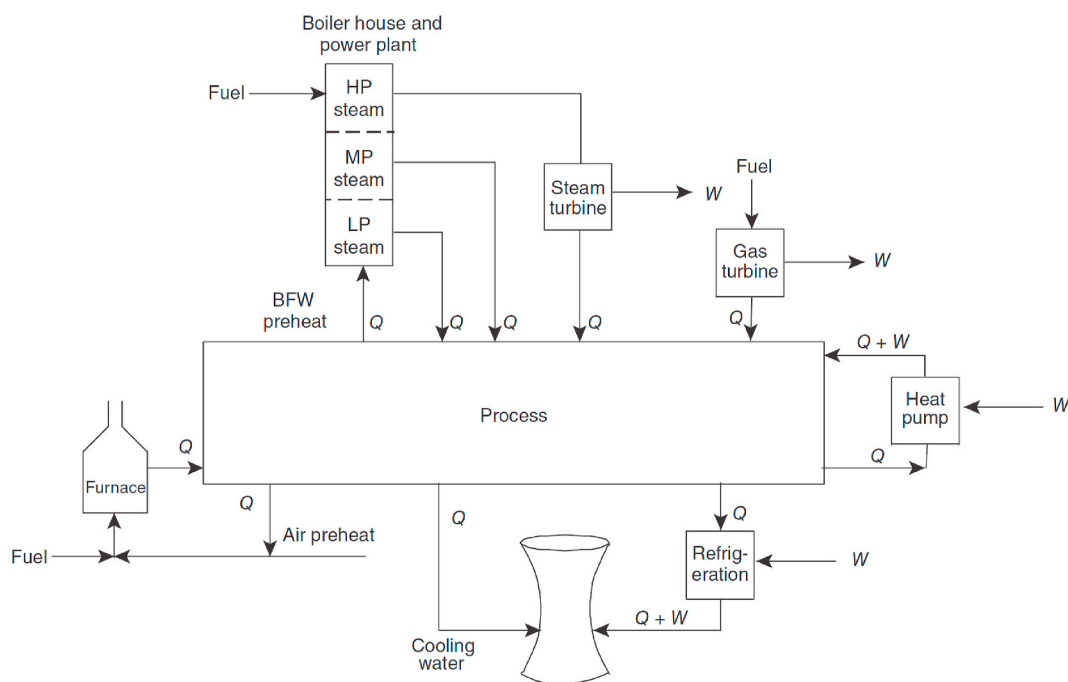

Fig. 12. Diagram of hot and cold utilities and pressures at a typical food manufacturing plant.

dioxide, equal to the national emissions from a country such as Jamaica [78].

5. Current and emerging technologies and practices for decarbonization

In this section, we move to our next two research questions: What options are available to decarbonize the food and beverage industry and thus make it more sustainable? What technical solutions and innovations exist to make the industry low, zero, or even net-negative carbon? Sticking with our sociotechnical approach, this section describes five different classes of technological innovations and practices that can help decarbonize the food and beverages industry, with an overview offered by Fig. 11. These four classes encompass: food supply and agriculture, food and beverage manufacturing, food retail and distribution, food consumption and end use, as well as a fifth category of 78 emerging breakthrough and potentially transformative technologies that cut across the four classes.

5.1. Options for food supply and agriculture

Substantial amounts of carbon can be mitigated within food supply and agriculture by improved land management, precision agriculture, and more decentralized and distributed food manufacturing.

Globally, agricultural sources of methane and nitrogen oxides account for nearly 60% of global non-CO₂ emissions, which come primarily from crop and livestock production [79]. Better *manure management systems* can reduce enteric fermentation from livestock, a large source of methane, along with better practices for managing the use of liquid systems in swine and dairy cow manure management. A particularly promising option is the use of biogas capture systems or anaerobic digestors that can convert slurry and manure from animal breeding into useful energy [21]. Enhancing livestock production efficiency can also indirectly reduce methane per unit of product through breed improvements, increased feeding efficiency through diet management, and strategic feed selection.

Other promising options for mitigating emissions from agriculture include deploying technologies and improving practices that increase

overall *nitrogen efficiency* while maintaining crop yields. For example, slow or controlled-release nitrogen products contain nitrogen fertilizer in a form that delays its availability for plant uptake and use after application, or which extends its availability to the plant significantly longer than rapidly available nitrogen products, such as ammonium nitrate or urea, which can degrade to gaseous forms of nitrogen including nitrous oxide [79]. Another report confirms that within agriculture, resource efficient farming, especially carbon-absorption practices and low emission fertilizers and feeds, offer significant mitigation potential [80].

Precision Agriculture provides tools for tailoring production inputs to specific plots within a field, thus potentially reducing input costs, increasing yields, and reducing environmental impacts by better matching inputs to crop needs [81]. Technologies involving precision imagery, sensing and control technologies are available to more precisely determine how much fertilizer is needed, minimizing over-fertilization practices that lead to emissions. These technologies can also help farmers apply fertilizers under conditions that would increase nitrogen absorption by plants while decreasing nitrogen transformation. Precision dairy cattle farming and precision livestock farming programs can deliver similar dividends for the rearing of animals [82].

Another promising option relates to decentralizing food chains and pursuing more *distributed forms of agriculture or food supply*. Producing food closer to its point of consumption not only minimizes the energy required for transporting and delivering it, but it could also reduce requirements for food storage and refrigeration. As one study noted, “distributed manufacture methods, in which only valuable ingredients are transported and other ingredients added later at the local level may lead to more energy efficient food chains.” [3] Another writes that “distributed and localized food manufacturing has been identified as a promising strategy towards future sustainable systems.” [83] Decentralization can achieve its sustainability benefits by better producing food at scale, optimizing the shelf life of foods, and minimizing wasted ingredients and resources as well as creating a more minimal need for additives, pretreatments and chemicals to preserve food for longer periods of time. One innovative idea is for “central kitchens” where fresh foods can be made cooked very close to their points of

Table 8
Food and beverage industrial processes with the greatest potential for steam or heat recovery.

Process	Industry	Process Temp (°C)	Purpose
Bread Proving	Bakery	40	Humidity control
Bread Baking	Bakery	230–270	Humidity control/glaze effect
Steam cooking tunnels	Vegetables	96	Cooking
Meat cooking	Rice and grains	96	Cooking
	Seafood	75–95	Cooking
	Meat and poultry	85–90 for full steam cooking 180–200 for quarter steam + heat cooking	Cooking
Superheated Steam drying	Food processing	160–200	Drying
UHT milk sterilization	Dairy	135–150	Sterilization
Multi-effect evaporators	Dairy	140–150	Heating
Bottles sterilization	Drink	100–116	Sterilization
Sugar juice concentrating/evaporation	Sugar	120	Heating
Sugar cane mills	Sugar	250	Milling/cogeneration
Air compressors (water cooling)	Food & drink	60	Process water heating
Air compressors (air cooling)	Food & drink	40	Space heating
Cooking	Food & drink	110–115	Space heating Water for in plant use
Boiler flue	Food & drink	~200	Economizer for water preheating
Spent cooling water	Food & drink	Up to 90	Water for in plant use
Condensate return	Food & drink	Up to 90	Water for in plant use
Ovens	Bakery	150–250	Air preheating, space heating, water heating
Fryers	Meat & poultry	Up to 200	Air preheating, space heating
Dryers	Food	160	Preheating dryer air inlet
Evaporation and distillation	Drink	~100	Heat pumps
Refrigeration	Food	~60	In plant hot water supply
Pasteurization	Dairy	~70	Hot water supply
UHT process	Dairy	135	Space heating, hot water for in plant use
Sterilization	Food & drink	140–150	Space heating

Source: Authors modification of [31].

consumption—especially foods with high water activities or thermal sensitives, such as vegetables, milk, meat, and fish products [84]. The co-location of food manufacturing centers and biorefineries for food waste would lead to huge potential improvements in both energy efficiency (via synergies for energy, heat, steam, and water) and logistics (via synergies for labor, transportation, and process agents) [85]. Decentralization would lastly facilitate the possible coupling of food supply centers with biorefineries that could better grapple with, and increase the efficiency of, food waste recovery [86,87].

5.2. Options for food and beverage manufacturing

Options for decarbonizing food and beverage manufacturing are

Table 9
Thermal management and waste heat recovery applications and examples from the food and beverages industry.

Subsector	Description
Meat production	Swedish meat plants achieved 5–35% reduction in carbon dioxide emissions using heat exchanger networks and heat pumps
Production and preserving of poultry	Liquid-liquid and gas-gas heat recovery have reduced space heating needs by 20%
Fish processing	Heat recovery and absorption chilling have reduced energy needs by 10%
Preserving potatoes	Heat recovery reduces the need for preheating and cooking by 22%
Operation of dairies and cheesemaking	Waste heat recovery can improve the energy efficiency of spray drying and pasteurizing by 31%
Grain mill products	Waste heat recovery can improve the efficiency of drying by 40%
Manufacturing of animal feeds	Waste heat recovery can improve the efficiency of evaporators and effluent concentration by 20%
Manufacturing of biscuits	Insulation and improved design can reduce the energy consumption of heat exchangers by 45%
Milk production	Spray drying and heat exchangers can save 10–30% of energy
Dairy operation	Air compression, after cooler drying and plate heat exchanges can save 35–95% of energy needs

Source: Compiled by the authors from [31,99].

equally varied, and include automation and process optimization; thermal management and heat recovery; the diffusion of renewable sources of energy; the implementation of energy efficiency and the pursuit of more sustainable packaging.

Automation and robotics in the industry have already been credited with improving energy and resource efficiency [33,34,88]. This includes fairly standard automated cutting and forming machines, ovens, mixers, blending machines, sortation equipment, filling equipment, and packaging and wrapping equipment. Some particular subsectors, such as food canning and materials handling, are almost entirely automated [88, 89]. As one industry report highlighted: “Automation is now a necessity in the food industry to address the required levels of quality control, production speed, labor shortages and overall profitability.” [90] Yet further automation would assist with “lights-out manufacturing” and “24:7 manufacturing” that could enhance productivity yields and lower energy consumption [91]. Some of the more quirky innovations discussed in the literature include a robotic nose to test alcoholic beer quality [92], a bioelectronic tongue to taste alcoholic spirits, dairy products and oils [93], and then our personal favorite, a robotic chef that can mix, load, and food ingredients similar to professional chefs, but on an industrial scale [32].

Process management and optimization is discussed with equal fervor for its ability to improve energy efficiency and lower carbon emissions [94]. This involves not necessarily changing sources of energy or fuel supply, but instead combining, harmonizing, or optimizing various processes within a facility or sector to reduce energy intensity. This can include [21].

- Optimization in the design of more efficient and effective technological approaches for food and drink processing and packing;
- Optimization in the understanding of how processes work and better process control, applications of automation, and flexibility through scheduling and logistics;
- Optimization in sensors and equipment for measurement and intelligent adaptive control of core parameters;
- Optimization of processing requirements to improve quality and efficiency without compromising safety;
- Optimization of waste recovery and better use of byproducts.

In many cases, facilities will have hot and cold utilities (or pipes) side by side, all using varying degrees of high pressure, medium pressure,

Table 10

Realizable technical potential of renewable energy technology for the food and tobacco sector in the “ambitious development scenario” scenario (in EJ/yr) by 2030.

	Low temperature	Medium temperature	High temperature	Total
Biomass	2.8	1.9	N/A	4.8
Solar thermal	0.9	0.6	N/A	1.4
Solar cooling	0.1	N/A	N/A	0.1
Geothermal	0.2	N/A	N/A	0.2
Heat pump	0.4	N/A	N/A	0.4

Source [101].

and low pressure steam. As Fig. 12 suggests, there is ample space to combine or optimize these flows of steam or utilities within a facility. Whenever hot and cold utilities are close enough to each other in range, one simple but effective technique is known as “pinch technology,” with the pinch representing the position where hot composite and cold composite curves are at their closest and can be optimized for efficiency [26]. Pinch technology enables minimum process heating and cooling needs to be determined prior to design or construction [3]. This has been an effective way of lowering energy costs and capital costs in the brewing sector, where pinch technology was able to reduce energy requirements by 24%, and with a payback time of three to four months [26]. Similarly, pinch technology has been used in the milk powder industry to save thermal energy by up to 51% [3]. Other forms of process optimization relate to the configuration of whole processing lines, major plant units, and equipment layout [95].

Improved thermal management and heat recovery came up repeatedly as an option in the literature [96]. It has been estimated that at many food processing facilities, process heat alone accounts for about 60–70% of total energy needs [3,72]. Some particular subsectors, such as baking, have extreme energy inefficiencies and heat losses—the energy efficiency of an average wafer baking machine is reported to be only 35%, with the rest of the total energy lost to “atmospheric discharge.” [97] Other processes, such as evaporation and pasteurization, occur at fairly low temperatures below 200 °C, meaning they can be suitable for heat exchange or the recycling of low to medium grade heat [98]. Although some techniques such as pasteurization are energy efficient (95% of heat in pasteurizers is recovered), the potential for waste heat recovery in other processes is substantial, with 8 Petajoules of estimated heat losses alone for the United Kingdom [99]. Improved thermal management and waste heat recovery have been proven as very effective techniques to offset these losses in a variety of contexts, summarized by Tables 8 and 9 (and as something we discuss again in Section 9.2). Onsite steam, electricity, and heat production, via distributed generation, co-generation, or combined heat and power, can also improve energy efficiency and reduce losses (and improve resilience and security of supply) [100].

The adoption of renewable sources of energy substituted for fossil fuels can further lower carbon footprints. The International Renewable Energy Agency projects that after the pulp and paper sector, the food and tobacco sector has the greatest potential for the adoption of renewable sources of electricity or heat. They project that 60% of existing heat demands can be provided instead by renewable energy, especially those needing low to medium temperatures [101]. As they summarize in Table 10, the options with the most potential are better integration of biomass energy sources, solar thermal heating, and geothermal heat pumps. Heat pumps in particular can increase the drying efficiency of conventional air dryers and also operate as a dehumidifier [72]. Substituting biomass for coal or natural gas, especially biomass waste or biogas from anaerobic digestion, could lead to “very big” emissions reductions, fuel switching from fuel-burning boilers to electric heating equipment utilizing renewable energy also offers significant emissions gains [60]. Anaerobic digestion and the use of biogas digestors is seen as

an important option for the dairy industry, due to the presence of live-stock and resulting manure [41,102]. Solar energy in particular can be utilized for agriculture [103] as well as drip irrigation systems in developing countries [104–106].

Energy efficiency and demand management are seen as “vital for the sustainable development of the food industry” [72] and “a crucial means for sustainable production.” [107] Energy efficiency solutions can be divided into three categories of options at the scale of food and beverage manufacturing: general efficiency, energy-efficient technologies and efficiency accelerator products [60]. General efficiency efforts include better energy management and maintenance practices, things like avoiding idle equipment, better production scheduling, and correctly sizing and maintaining controls, motors or steam networks. Energy efficient technologies include the adoption of new devices such as advanced refrigeration technologies, or installing advanced insulation on equipment and piping. Accelerator technologies include microwave drying and heating, advanced oven technologies (including electric ovens), or mechanical and thermal vapor recompression techniques (see some of these in Section 5.5). The energy savings from efficiency can be substantial: switching from pure to mixed refrigerants can reduce the energy needed for refrigeration by 16.3–27.2%; better design of fans, pumps and mixers can reduce energy needs by 50–90% for some processes; lighter weight conveyors can reduce energy needs by 10% [108]. Even simple practices such as installing pump controls, or turning off refrigerators when ambient temperatures drop below freezing, can save 10–30% of required energy or electricity [109]. One survey of 93 food and beverage manufacturers, alongside other industries, noted that experience in the adoption of energy efficient technologies and the commitment of top management were the two most critical drivers ensuring its uptake [110].

Another option is sustainable packaging, including active packaging, intelligent packaging and smart labels (some of which we return to in Section 5.5). The industry uses a prodigious amount of plastic, cardboard, and glass to protect its products [86]. Active packaging can perform a desired function beyond merely providing a barrier to the external environment, such as a container of a readymade meal that then serves as a plate to eat the product on, or edible coatings [111]. Intelligent packaging can inform or communicate to the consumer the properties of the food, or aspects of its history. Smart packaging or labels can automatically detect when temperatures change or food has gone bad or is contaminated [112]. All three can contribute to sustainability goals by extending packaging uses, or better conveying information to consumers.

5.3. Options for food retail and distribution

At the food retail and distribution level, grocery stores and supermarkets can adopt many of the same energy-efficiency practices and technologies as industry—including those for refrigeration and lighting. The National Renewable Energy Laboratory in the United States estimated that 50% net site energy savings could be achieved at most grocery stores throughout the country by Ref. [113]:

- Reducing lighting power density by 47% and installing occupancy sensors;
- Adding a vestibule to the front entrance to reduce infiltration;
- Equipping rooftop HVAC units with higher efficiency fans;
- Installing daylighting sensors;
- Replacing frozen food refrigerated cases and display cases with vertical models with sliding doors, anti-sweat controls, and/or hot gas or electric defrost systems;
- Reducing south façade window-to-wall ratios by 50%.

The British Retail Consortium similarly noted that major energy improvements in retail operations and grocery stores have been achieved, mainly due to improving energy monitoring and control systems,

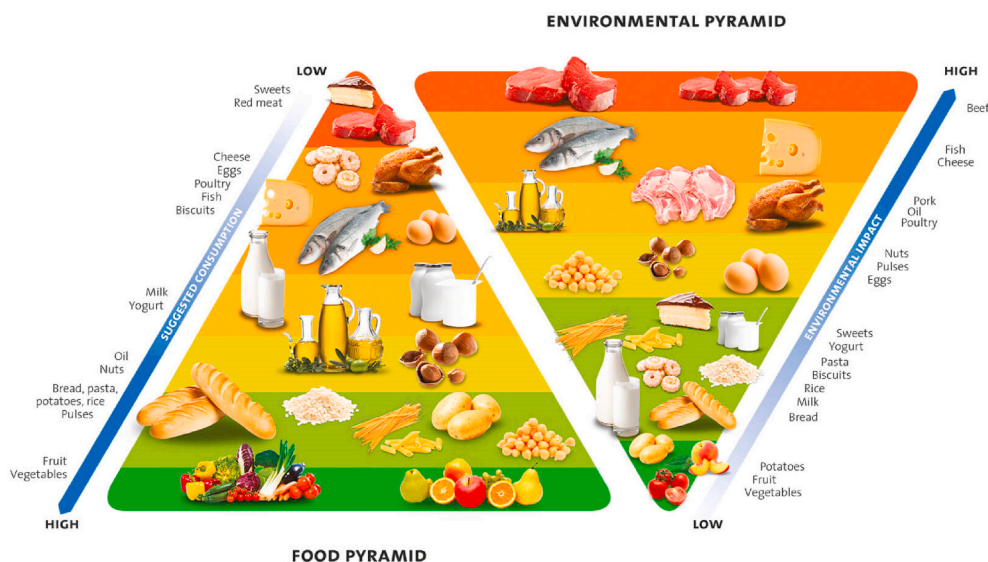

Fig. 13. The Double Food Pyramid aligning nutritional value and environmental impact. Source: [124].

the use of more efficient chillers and refrigerators, the installation of LED lights, and better HVAC equipment [114]. It also mentioned the uptake of distributed generation and small-scale renewable energy systems, the use of alternative fuels in transport (including biodiesel) and route optimization models for food delivery, and staff training and awareness in ways to reduce energy use. Other reports emphasize the ability to design “zero energy stores” and low-energy designs that include passive use of daylight, natural ventilation, better heat exchange, and hyper-efficient lighting and refrigeration [115].

But the retail part of the system can also utilize distinct approaches such as *sustainable sourcing* and *supply chain management*. Sustainable sourcing refers to when food companies or supermarkets commit themselves publicly to lower the carbon, energy, or environmental footprint of their products. This can include pledges such as those from Associated British Foods for reducing the amount of palm oil or sugar in their products; or General Mills to ensure that more than 50% of their raw materials are “sustainably sourced;” or supermarkets committed to cage-free eggs or grass-fed beef [7]. Supply chain management refers to retailers seeking to align farmers, manufacturers, and delivery systems so that better economies of scale are reached and efficiency is improved [33]. This can include orienting supply chains to reduce food waste, to reduce packaging, or to avoid unnecessary handling, treatment, and transport [60].

Another option is to reduce and minimize *food waste*. Although some food waste is lost during processing and distribution (about 7% [116]), most is generated downstream by a mix of retailers and grocery stores (covered here) and consumers and households (covered in the next section 5.4) [60]. In the United Kingdom, the national grocery sector voluntarily joined the Courtauld Commitment, which saw them reduce 4.5 million tons of packaging and food waste with a corresponding emissions savings of 8.1 million tons of carbon dioxide from 2005 to 2012 [60], largely through increased awareness, enhanced recycling, and behavioral change programs. WRAP, a civil society organization, has separately managed a series of initiatives, including the “Love Food Hate Waste” campaign, which have collectively saved another 12 million tons of food waste at a value of £24 million and avoided about 40 million tons of carbon dioxide equivalent [60]. The retail sector has also begun to implement more efficient food recovery programs [10], and to increase overall rates of recycling, reductions in volume, and decreases in production scale [117]—which all reduce waste.

5.4. Options for food consumption and end use

On the demand side of the sociotechnical system, options also exist to decarbonize food and beverages. Already changes in consumer preferences have shifted in some ways that are reducing the environmental footprint, or improving the health, of eating patterns. In the United Kingdom, the food and drinks industry has noted that between 2015 and 2020, it is selling 14.3 billion fewer teaspoons of sugar, 1 trillion fewer calories, and 35.5 million less kilograms of total fat—all because households changed their preferences. [118].

One option for accelerating decarbonization is to promote *plant-based alternatives to meat*, some of which may be derived from cellular agriculture. Products such as the Impossible Burger or the Beyond Burger attempt to mimic the taste of meat but have far lower energy requirements and affiliated carbon emissions. As the National Academies of Science noted, compared to a conventional beef burger, some of these alternatives use 99% less water, 93% less land, have 90% fewer greenhouse gas emissions and use 46% less energy [24]. Green proteins can also replace grass and clover-grass in the production of some livestock, leading to consumer products (such as steaks and hamburgers) that have a much lower carbon footprint [119]. Indeed, one study noted that the use of meat-substitutes in readymade meals such as spaghetti Bolognese, cottage pie and lamb curry could reduce energy and climate impacts by up to 27% [78], without necessarily comprising taste, quality, or consumer satisfaction. Another report affirms that alternative meat proteins are a promising mitigation option [79].

Another option is to *change diets* to be far less carbon intensive than what they are. Global society is not only becoming more reliant on fossil fuels to grow crops, but dependent on meat, livestock, and animal products. These sources of food, however, are more energy and carbon intensive than simply eating vegetables and plants. On a consumer lifecycle basis, it has been estimated that food and drinks account for about 17% of greenhouse gas emissions caused by private consumption in Europe [120]. Yet many of these emissions can be reduced. The Barilla Center for Food and Nutrition has designed a “double food pyramid” to help align the nutritional value of food with its presumed environmental and climate impacts [12]. This double pyramid, shown in Fig. 13, reveals how foods with a lower environmental impact are also better for one’s health, while foods with a high environmental impact should be consumed only in moderation. It underscores how changes in to a less carbon intensive diet reap co-benefits in terms of both improved health and reduced environmental impact. One assessment estimated that switching to a plant-based diet would do more to stop global

Table 11

78 commercially available, emerging, and experimental innovations for the food and beverage industry.

Level of sociotechnical system	Commercially available but not yet widely utilized (as of 2020)	Emerging soon with working prototypes (as of 2020)	Experimental and likely only after 2025
Agriculture and food supply	<ol style="list-style-type: none"> 1. Urban horticulture 2. Advanced water reuse schemes 3. Biochar application to soils 	<ol style="list-style-type: none"> 1. Vertical farming and urban horticulture 2. Photobioreactors 3. Algal biorefineries 4. Carbon capture and storage 	<ol style="list-style-type: none"> 1. Future food factories 2. Nanotechnology
Food and beverage manufacturing	<ol style="list-style-type: none"> 4. Membrane emulsification 5. Extrusion technology 6. Food irradiation 7. High pressure processing 8. Ohmic heating 9. Ammonia refrigeration 10. Supersonic steam shockwave 11. Supercritical CO₂ 12. Remote condition monitoring 13. Pulsed light/UV in packaging 14. Cold plasma 15. Aseptic filling 16. Advanced robotics and automation 17. Machine vision 18. Impingement air flow freezing (Holland) 19. Vacuum cooling 20. Microwave heating 21. Air cycle refrigeration 22. Online food safety and quality indicators 23. Hydrodynamic cavitation 24. 3D (three dimensional) printing of food 25. Advanced starter cultures 26. Advanced surfactants 27. Superheated steam drying 28. Biosensors 29. Hurdle technology 	<ol style="list-style-type: none"> 5. Pulsed UV in food 6. Pulsed electric field in kitchens 7. Neutral electrolyzed water 8. Ozonated water 9. Exchanger fouling detection 10. Continuous dense phase CO₂ 11. Infrared heating 12. Radio frequency heating 13. Hyperspectral imaging 14. Bernoulli grippers 15. Soluble gas stabilization 16. Laser sealing 17. Microsieves 18. Coflux 19. Conditioned gas cooling 20. Pulsed electric field in pasteurization 21. Pulsed electric field in cooking 22. Foreign body detection by spectrometry 23. Magnetic refrigeration 24. Modified atmosphere packaging 25. Electroosmotic dewatering 26. Thermoacoustic heat engines 27. Thermo-Catalytic Reforming 	<ol style="list-style-type: none"> 3. Single homogenization/mixing (SHM) valves 4. Sonication 5. Heat free shrink wrapping 6. Acoustic refrigeration 7. Electrocaloric refrigeration 8. Optical refrigeration 9. Hydraulic refrigeration 10. Continuous oscillatory baffle reactor 11. Spinning disk 12. Electric arc discharging 13. Microfluidics
Food retail and distribution	<ol style="list-style-type: none"> 29. Drones and automated vehicles for food delivery 	<ol style="list-style-type: none"> 28. Edible food packaging and coatings 	<ol style="list-style-type: none"> 14. Large-scale hydroponic produce 15. Fully automated food management
Food consumption and end use	<ol style="list-style-type: none"> 30. Apps for food-sharing 31. Organic farming 32. Meat substitutes 	<ol style="list-style-type: none"> 29. Zero-carbon readymade meals 	<ol style="list-style-type: none"> 16. Robotic chefs 17. Fully automated smart homes

Source: Authors compilation and modification from [12,34,72,83,84,131–154].

warming than switching from a sports utility vehicle to a Toyota *Camry* [121]. The “slow food” movement also aims to better match food production with natural cycles and principles of sustainability, and in this regard also offers a more subtle attempt to change diets and behavior [122,123]. We will return to some of the specific benefits of lower carbon diets in section 6.1.

Yet another option, in tandem with the retail sector, is to better manage and reduce food waste via *food sharing*. The Food and Agricultural Organization estimates that, shockingly, about one-third of food produced for human consumption is lost or wasted globally, amounting to 1.3 billion tons of wasted food per year [39,125]. In the United States, up to 40% of food is wasted [126]. Interestingly, although food waste does occur throughout the manufacturing and retail parts of the system, households account for the largest single share of waste (53%) in Europe, where the average person wastes 173 kg of food per year—far more than his or her weight [127]. Food sharing activities have been shown to reduce waste, especially given that they are most active in big cities that also have higher amounts of wasted food than rural areas. An exploratory database in 2019 revealed more than 4000 different food sharing networks and activities oriented towards reducing food waste in 100 cities across Africa, Australia, Asia and the Middle East, Europe and North and South America [128]. Although evidence is still scarce, due to the recency of these trends, there is an indication that they can save significant amounts of waste—with one network of charities in Italy alone reducing food waste by 720 tons over the past 1.5 years [129].

5.5. Emerging breakthroughs and transformative innovations

This final category of options is perhaps the most uncertain and difficult to classify, but it has the potential to transform the food and

beverage system across all of its levels with *breakthrough* and *emerging innovations*. The need for transformation is evident in that step-changes may be needed to make food and drinks more sustainable. The National Academies of Science put it this way:

Approaches focused mainly on making incremental fixes to problems that arise from complex influences—some biological and physical, some man-made—are resistant to simple solutions. The food system is vast, complex, and interconnected. The “wicked” problems—intractable problems with many interdependent factors that make them difficult to define or solve—will require a radically different approach to understand and uncover solutions that can only be found when explored beyond the traditional boundaries of food and agricultural disciplines [19].

The industry itself even notes that innovation has been a driving force in earlier improvements that have reduced the cost of manufacturing, enhanced logistics, or expanded product diversity [34]. Radio Frequency Identification Technologies have dramatically lowered the cost of manufacturing and shipping. Genetics and designer genotypes have led to new materials. Novel package ingredients have led to chilled ready meals and smoothies. High Pressure Processing has made food appear fresher through lower impact preservation techniques. The microwave, tetrapacks, nanotechnology and modified atmospheres have led to new preparation and packaging options.

Precision biology and the related ability to design and rapidly produce food in a distributed manner has been proposed as another potentially disruptive force in the food industry. One report has suggested that modern foods based on precision biology may in the coming decade disrupt the agricultural industry, resulting in the production of proteins that are 10 times less expensive than those from animal meat

Table 12
Three pathways for the decarbonization of food and beverages in the United Kingdom.

Pathway	Total Discounted Capital Cost 2014–2050 (million £)	Cumulative CO ₂ Abated 2014–2050 (million tons)	Projected Impact on Fuel or Energy use and Fuel or Energy cost
Business as usual	2000	13	This pathway includes approaches such as improved process design, fuel switching(biomass), and improvements in steam production and distribution. In the period 2014–2050, this pathway would result in an overall saving in energy and fuel used. The projected value of this saving will depend on the fuel cost forecast adopted.
Modest electrification	10,000	53	This pathway has similar options to business as usual but adds electrification of heat. In the period 2014–2050, this pathway would result in an overall saving in energy and fuel used. The projected value of this saving will depend on the fuel cost forecast adopted.
Maximum technology	13,000	70	The main characteristic of this pathway is a projected significant transfer of energy use from natural gas to electricity resulting in an overall increase in energy use and costs but with notable reduction in CO ₂ emissions. The scale of the increased cost will depend on the fuel cost forecast adopted.

Source: Authors modification of [60].

and freeing for other uses, such as reforestation, up to 60% of the land currently used for livestock and feed production. According to one report “U.S. greenhouse gas emissions from cattle will drop by 60% by 2030, on course to nearly 80% by 2035. Even when the modern food production that replaces animal agriculture is included, net emissions from the sector as a whole will decline by 45% by 2030, on course to 65% by 2035.” [130] While such projections may prove overly optimistic, they do reinforce the notion that emerging technologies can potentially disrupt the food industry and bring substantial climate benefits.

Our systematic review revealed a plethora of radical and possibly transformative options for the future, which we summarize in Table 11 and offer a far more detailed inventory in Appendix I. The table depicts 78 (!) new innovations or technologies in total across different elements of the sociotechnical system, classified according to the three temporal groupings of commercially available but not yet widely diffused (as of 2020); prototypes and emerging soon; and those at the experimental or conceptual stage only. Most of these innovations occur in food and beverage manufacturing and processing, although others include the use of photobioreactors in biorefineries to produce food, automated robots or artificial intelligence in supermarkets, or zero-carbon readymade meals to eat in the home. Also interestingly, more innovations are commercially available but not yet utilized (32) than are both emerging (29) or in experimental stages (17).

6. The benefits of decarbonizing food and beverages

Although not quite as diverse as the literature on the topic of technology and innovation, our review did reveal a compelling collection of evidence documenting the benefits of decarbonizing food and beverages. These fall into four core areas: energy and carbon savings, cost savings, environmental protection, and worker satisfaction and health.

6.1. Energy and carbon savings

Given the energy intensities and inefficiencies described in the sections above, the energy and carbon savings to be achieved from decarbonization are vast—and cut across multiple levels of the sociotechnical system.

In *food supply and agriculture*, most farms in the United Kingdom could reduce average water requirements by 35% (and associated reductions in energy inputs) without any reductions in gross margin output [155]. Another study of the agricultural supply chain for beer in the European Union projected that its carbon footprint could be cut in half through the use of better bottle recycling, a switch to local and organic barley, and utilizing rail instead of road transport [156].

In *food and beverage manufacturing*, one study noted that “the effect of increasing the efficiency of energy use is to reduce operating costs, lower production costs, increase productivity, conserve limited energy

resources, and reduce emissions, most especially in the case of greenhouse gases such as CO₂” [26]. A combination of retrofits and demand side management are estimated to save 14%–20% of energy use across three different food and beverage manufacturers in Nigeria as well as between 140,000 and 187,000 kg of carbon dioxide emissions per year per facility [157]. Similarly, in Canada, a study projected that the use of heat pumps throughout the food industry would save 60% of energy use for hardwood drying and also enhance efficiency of milk production, fish drying, and refrigeration by a factor of two or three in each case [99]. A similar study of heat pumps in the food and drink sector in the United Kingdom estimated that carbon savings could reach 2.6 million tons of carbon dioxide equivalent per year by 2030 [158]. It is estimated that up to 2.85 TWh of recoverable heat is being wasted each year from the food and drinks processing sector in the United Kingdom [159]. Better energy management systems and more efficient refrigerators are estimated to save 10.7–20.1% of electricity use across food processing facilities in the United States [70].

In the *food retail and distribution* part of the system, simple practices such as defrosting walk-in freezers can add up, improving performance (and reducing energy use) as much as 30% [160]. Section 5.3 noted a study from NREL calculating that almost all grocery stores in the country could cost effectively reduce their onsite energy needs by 50% by investing in commercially available efficiency technologies with fairly rapid payback times [112]. More efficient industrial baking ovens at supermarkets in the United Kingdom would also save as much as 43 tons of carbon dioxide emissions per year per oven [161]. A final study calculated that the uptake of trigeneration systems, which are systems that produce electricity, heat and cooling, in the food retail industry could save up to 50 tons of carbon dioxide per year per retailer and with deployed systems paying for themselves within four years, as long as gas and electricity prices remain neutral or increase [162].

At the level of *food consumption and end use*, changes in diet can indeed reap significant carbon savings, with one study of carbon footprints in Europe noting that practices such as eating less meat, using less packaging, and sourcing more local foods could cut the carbon footprint of eating in half [163]. Similarly, in Sweden, one study compared two diets that had similar amounts of food energy, but differed by a factor of four in terms of their lifecycle energy inputs and carbon emissions (the high-carbon diet needed more than 50 MJ of energy, the low-carbon diet fewer than 13 MJ) [164]. Refrigeration can be more efficient, too. A survey of refrigeration use in homes in Australia suggested that the replacement of inefficient refrigerators could lead to average energy reductions of 60% [165]. Low-carbon refrigerants also have the added benefit of reducing associated F-gas emissions, which are much more potent than both methane and carbon emissions [166].

Some assessments seek to quantify particular decarbonization pathways for the food system. The United Kingdom has done this in Table 12, noting three possible pathways of business as usual, with no changes to food manufacturing or retail; one of modest electrification of heat; and

Table 13
Achieved energy savings and rate of payback at an Indian beverage manufacturer.

Energy-saving projects	Per annum savings kWh	Annual savings in USD (\$)	Initial cost in USD (\$)	Payback period (months)
Replacing 10 tonnage per hour (TPH) boiler with six TPH boiler	–	74,374	85,825	13.85
Replacing 36 W white tube lights with 16 W Light Emitting Diode (LED) tube lights	661,305	85,667	30,054	4.48
Installing Variable Frequency Drive (VFD) in beverage filling pumps	17,184	2090	1431	8.22
Replacing fluid coupling motor with efficient VFD motor	8592	1044	2175	24.65
Converting chiller plant to humidification plant	120,000	14,316	42,950	35.29

Source [4].

one of maximum technology deployment. These latter two pathways could reduce carbon dioxide emissions by as much as 53 to 70 million tons by 2050.

6.2. Cost and financial savings

Less often discussed in the literature are verified cost savings resulting from avoided energy or mitigated carbon, especially given that in some sectors (such as consumption and end use) low-carbon options are still more expensive than high-carbon ones. Nevertheless the literature does discuss cost and financial savings in some contexts.

The most frequently mentioned contexts were food and beverage manufacturing. This is because some particular sectors require greater energy inputs than others. A survey of the United States noted that the top four energy consumers for food and beverages (as a % of overall operating costs) were animal processing (26.8% of costs spent on energy), grain and oilseed (18.8%), fruit manufacturing (11.9%), and dairies (11.7%) [72]. This gives rise to economically valuable opportunities to cut costs as illustrated by a number of case studies that follow.

For example, in India, a large brewery and beverage manufacturing facility adopted a variety of energy saving devices, including a more efficient boiler, better lighting, and better electrical drives [4]. The energy savings were not only significant in terms of avoided losses, they paid for themselves quite quickly, with lights and pumps paying for themselves in less than a year, and even the boiler and chiller plants paying for themselves in less than three years (see Table 13).

The global conglomerate Nestle integrated and optimized the supply of heat at one of their confectionary factories. As shown in Table 14, these options all delivered between 3.77% and 5.72% energy savings

Table 14
Achieved energy savings and rate of payback at Nestle confectionary.

Opportunities	Min steam reduction (tons)	Max energy reduction (%)	Min energy reduction (%)	Capital cost (£)	Min cost saved (£)	Max cost saved (£)	Long payback (years)	Short payback (years)
Direct heat optimization	223	0.62%	0.26%	24,392	4753	11,921	5.13	2.05
Heat exchanger optimization	148	0.26%	0.17%	14,997	3345	4972	4.48	3.02
Process optimization	238	0.33%	0.28%	13,687	5366	6297	2.55	2.17
Improved interzonal control	33	0.04%	0.04%	422	740	740	0.57	0.57
Indirect heat optimization	2570	4.48%	3.02%	273,533	34,680	80,731	7.89	3.39
Total	3213	5.72%	3.77%	321,031	48,884	104,661	3.07	6.57

Source [167]: Expected total steam consumption was 49,425 tons

and paid for themselves fairly quickly, in between 3.07 and 6.57 years [167]. Nestle also found that more minor upgrades to things like replacing compressed air usage with a dedicated blower, insulating high temperature pipes and undertaking vacuum production in dryers would also have estimated payback periods of three years or less [72].

Kraft Foods undertook similar improvements such as better thermal and process management and the installation of industrial heat pumps at one of their processing plants. This saved them 53 million liters of water and US\$250,000 in water and energy costs per year (in 2020) [168].

Hillsdown Holdings, another conglomerate that owns more than 200 independently operated subsidiaries in the food and beverages sector, ran a “environmental best practice” program in the United Kingdom that sought to minimize waste and improve efficiency at various affiliated facilities [169,170]. This initiative achieved a total annual energy savings of £618,000 with 70% of savings coming from no to low cost measures, and an overall payback time of less than 6 months.

Finally, at the national level, one study examined cost-effective energy efficiency efforts in the food and beverage sector of six European countries—Austria, France, Germany, Poland, Spain, and the United Kingdom—and it found that across the board, regardless of specific country, energy savings of up to 45% and carbon savings of up to 30% (~30,000 t CO₂ equivalent in the audited companies) were possible [71]. More promisingly, however, it found fairly rapid payback periods for a multitude of energy saving, or energy generating, measures (see Table 15). Some had payback periods of far less than 3 years and most had payback ratios in less than 10 years.

Table 15
Estimated energy savings, carbon savings, and payback periods for the food and beverage industries of Austria, France, Germany, Poland, Spain, and the United Kingdom.

Efficiency measure	MWh identified	tCO ₂ e mitigated	Payback (Y)
Energy saving			
Process optimization	20,440	5340	2.8–9.7
Heat recovery	12,320	3220	2.4–5.6
Heat supply optimization	12,000	3135	1.7–13.7
Cold supply optimization	9230	2410	7–18
Other	80	20	4.8–5.2
Energy generating			
Combined Heat and Power	64,900	15,415	1.1–3.6
Solar heat	3720	970	14.9–45.9
Biomass	1415	370	6.6–26.8
Absorption Chilling Machine	660	170	3.2
Solar PV	50	15	13.7
Heat pump	70	20	7.8

Source [71].

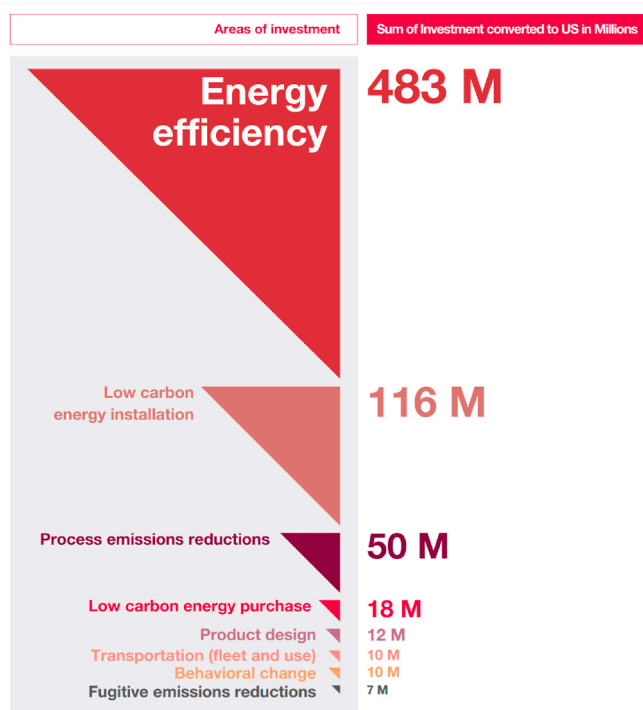

Fig. 14. Investment across agricultural supply chains in climate mitigation and decarbonization options.

6.3. Other environmental co-benefits

Many of the options intended to save energy or carbon within the sector also save water, minimize waste, or lead to other positive benefits. One study noted that carbon prevention options also led to less packaging waste, more composting, less water use, and the abatement of air pollution, especially of particulate matter [171]. Another study noted that reductions in energy and emissions also had the potential to enhance environmental compliance (lowering fines and liability), prevent biodiversity loss, and improve corporate reputation [172]. Reduced water consumption and use is prominently mentioned in the literature as a recurring co-benefit to lower-carbon food and agricultural systems [173–176].

Less carbon intensive diets that avoid meat or minimize animal proteins could yield innumerable benefits by displacing and reducing the impacts from factory farming, given that animal breeding uses 75% of the world's pastures and agricultural areas and emits about 18% of greenhouse gases [143]. Other benefits include lowering the risk of zoonotic diseases and animal pathogens, improving the vitality of global soils, and also lessening antimicrobial resistance among animal populations.

6.4. Worker satisfaction and health

A less discussed benefit to decarbonization was worker satisfaction and indirect improvements in health. Options to improve efficiency, process management, and reduce waste also have the ability to lower the use of hazardous materials within the sector, especially dust and chemicals [177]. In doing so, they can improve occupational safety and lead to more healthy working environments.

Moreover, the Ellen MacArthur foundation attempted to quantify the negative costs of pollution and inefficiency within the food and agricultural system, and they estimated that the sector contributes to a shocking US\$5.7 trillion in extra costs, many of which relate to decreased healthcare (US\$1.6 trillion) and less resilience for social and environmental systems (in 2019) [13]. They noted specifically that

avoiding 4.3 billion tons of carbon dioxide equivalent emissions corresponds to US\$900 billion in health gains due mostly to less pesticide use and exposure to farm workers, as well as less water pollution and therefore fewer waterborne and foodborne diseases, which cost society about US\$200 billion per year.

7. The barriers to decarbonizing food and beverages

Unfortunately, the benefits to decarbonization are not a given, and often face a pernicious set of barriers and challenges that prevent their achievement. Several taxonomies or inventories of these barriers exist, with varying level of detail or specificity to the food and beverages industry.

For example, in the United Kingdom the (formerly named) Department of Energy and Climate Change and the Department of Business, Innovation and Skills identified the “main barriers to decarbonization” as high capital cost and long investment cycles, limited financing, risk of not meeting required product quality or changing the character of products, risk of production disruption, shortage of skilled labor, shortage of demonstrated technologies, and lack of reliable and complete information [66]. Another study categorized barriers facing energy efficiency in industry across seven types or dimensions, which were technology related, information related, economic, behavioral, organizational, competence related, or awareness related [107]. Yet another study uses a more simplified classification of market related barriers, organizational and behavioral barriers, and policy barriers [31].

Our systematic review identified three interrelated, albeit distinct categories of financial and economic barriers, organizational barriers and managerial barriers, and behavioral and consumer barriers.

7.1. Financial and economic barriers

Perhaps due to the fragmented nature of the industry, cost benefit analyses of full decarbonization or even climate mitigation are scarce (we return to this issue in Section 9.1). But decarbonization would obviously entail costs that both food and beverage providers, and consumers, would likely be unwilling to fully bear. One assessment projected that a carbon tax that would mitigate emissions from the sector in line with the targets from the Kyoto Protocol would only add about 3% to the final cost of food and beverages [178]. Another study estimated the costs for building agricultural resilience to climate change and “aggressive” investments in productivity needed to become more efficient; they estimated this would need to be at least US\$7.1 to US\$7.3 billion per year (in 2009) [179]. One industry report in 2015 tracked current investment across agricultural supply chains in climate mitigation, and noted a total of US\$706 million (see Fig. 14), with the largest investments in energy efficiency and low-carbon sources of energy, although this is just one part of the entire sociotechnical system [180]. The report also claimed that the most significant impact food and beverage companies as a whole could have on climate is through agricultural production, which they calculated accounted for 86% of food-related anthropogenic emissions, suggesting a relatively minor impact of other parts of the supply chain (although the specific parameters of this calculation remain unclear).

That said, in Canada, one report suggested that the effects of climate mitigation and decarbonization were net positive rather than negative. It noted that Climate Smart certified food and beverage industries reduced emissions by 7% annually with a cost savings of C\$430,000. Furthermore, it projected that such reductions would add up to 250,000 tons of carbon dioxide and C\$100 million in net savings over the lifetime of the program [181]. (As we already noted above in Section 6, when one starts to capture the monetized value of food waste or energy losses, interventions do tend to quickly pay for themselves), although future research would be ideal in this regard (see Section 9.1).

Regardless of these differences in findings and scope, one certainty is that decarbonization will entail costs and as such it will require finance.

And yet high capital cost and long investment cycles are known to be a serious decarbonization barrier in the industry, especially given that equipment investments are often in the range of 20–40 years—creating very few moments when facilities or operations can economically upgrade or change technology [66]. Limited financing may also be available and firms often lack the resources to actually find financing that is available. One review of the food and beverage industry across six European countries noted that low capital available, high investment costs, strict budgets, limited information and the expense of financing were all serious barriers to improved energy management or energy efficiency [71]. Another systematic review of 25 years of academic literature on business models in the agri-food industry also noted that “internal barriers” such as “shortages of internal financing” were seen as the most significant impediment towards innovating [182].

7.2. Organizational and managerial barriers

This set of barriers relate to industry fragmentation and a difficulty in sharing best practices even when they exist. In most cases, existing innovation activities are in the domain of large multinational firms, but keep in mind that 95% of food sector entities are SMEs—without the skills or apparent need for big research and development efforts [34]. Another study warned that large-scale adoption of new technologies “is made more difficult by the diverse and fragmented nature of the food and drink subsectors.” [56].

When firms do innovate, they tend to focus on product innovation (new types of meals, new ingredients, new soft drinks) rather than process or manufacturing innovation (energy management systems, improved processing techniques) [40]. A report of the global food industry affirmed this point, and noted that most innovation recently has been focusing on product innovation or premiumization (selling higher quality products) and personalization (selling branded products for particular lifestyle segments), not investments in sustainability, energy efficiency, or emissions reductions [38]. As a glaring example: the industry spent more on developing and selling energy drinks than they did on R&D in energy and sustainability.

Other organizational barriers relate to risk aversion. In most firms, margins are limited, capital is unavailable, and food is often seen as a low-growth or even non-growth industry where business strategy is oriented towards higher value added products (such as readymade meals) rather than energy savings; it is also a risk averse sector given the need for food availability and safety. A final study raises almost the same conclusion, cautioning that “the practical implementation of sustainable improvements in the food industry is hindered by the vast product diversity, the specific and limited production periods, and the large distribution areas.” [116] This can make it “very challenging” to disseminate and adopt low-carbon technologies and practices [167].

At the level of management and strategy, most food and beverage companies, big and small, focus firstly on cost reduction and, at times, downsizing, and secondly on maintaining a competitive edge and expanding sales and products (and new trends such as healthier foods or smaller portions) [32,40] Energy savings or carbon abatement rates lowly compared to these priorities. As one report noted:

Energy efficiency is perceived by industry as important, but decarbonization is not systematically seen as a high priority in the current investment climate, because energy presents only a low proportion (2–10%) of total production costs across the sector, on average. Moreover, according to industry sources, the high market heterogeneity and product diversity, in what is a dynamic and highly competitive market driven by consumers and retailer demands, has put a constant pressure on product innovation and differentiation, frequently attracting management focus and available finance. Product safety and quality cannot be jeopardized, and therefore companies are often only willing to invest in technologies that have already been proven to be successful [23].

One industry manager from the Alliance to Save Energy in the United States put it this way:

Facilities are thinly staffed, running flat out every day to meet production goals. Therefore distractions aren't welcome. For them, routine is a good thing, and their mantra becomes “that's the way we've always done it.” So when you propose energy [efficiency projects for] a facility, you are really proposing changes to the way they operate. You have people in operations, finance, procurement, and engineering—all of whom will be impacted by energy management, and all of whom usually have some reason to resist change ... Decision makers are continually making a tradeoff between risk, time, and money. If you propose an energy efficiency measure that saves X dollars, the facility manager wonders what the additional costs are in terms of risk and time. What labor hours are needed to support energy efficiency efforts? Should they allocate labor hours to making dollars, or saving dimes? [183].

Confirming these sentiments, a systematic review of literature on the food processing industry found that the top two focal points for management were to reduce product defects and to follow the food law and regulations [184]—not to cut carbon emissions. For these reasons, even as of 2019, “most food businesses have limited awareness of the recent technological advancements in real-time energy monitoring or technologies for energy efficiency” [4].

7.3. Behavioral and consumer barriers

A final class of barriers cannot really be blamed on the industry, and instead relate to consumers and dietary patterns—which are moving generally in the direction of becoming more carbon intensive, rather than less. Global meat consumption has increased fivefold in the past seven decades – jumping from 44 million tons in 1950 to 242 million tons. Per capita meat consumption has more than doubled as well over the same period, from 17 kg per person per year to a worldwide average of 39 kg [59], or more than 100 g of meat per person per day [185]. Developing countries in particular, such as China and India, are eating more meat due to increasing wealth, better international trade links, and a social desire to mimic Western culture [186,187]. It is not just demand for meat that is increasing, but also the overall energy and carbon requirements of food production. The move towards more highly processed foods that need longer shelf lives requires more preservatives and increasing energy footprints [143].

Although some consumers may choose to eat organic, exercise, and adopt some of the changes in diet described in section 5.4, most do not. It is common for most consumers to know very little about food supply, and to have very little literacy or knowledge about the food system, leading to disconnection and ambivalence that contribute to climate and environmental impacts [55].

8. Financing, business models and policy instruments

Although the barriers above are interconnected and often potent, policy mixes and business models can be harnessed to overcome them. This section briefly describes both sets of topics from our systematic review.

8.1. Financing and business models

Given the financial and economic barriers mentioned in section 7.1, the literature does suggest the centrality and instrumentality of securing *finance* in overcoming these barriers [188]. At least three options arise from the literature. The first is the use of internal industrial funding from the food and beverage sector itself—securing financial resources through capital allowances, capital improvement projects, and company budgets is seen as a “key enabler” of energy efficiency and therefore

Table 16
Policy mechanisms for the industrial decarbonization of food and beverages.

Instrument	Description
Carbon emissions trading schemes	National and regional markets for carbon permits that can also be traded and sold, with some free allowances given
Voluntary and mandatory energy efficiency schemes	National and subnational programs and voluntary initiatives intended to promote energy efficiency practices and processes
Regulations on potent emissions	Restrictions on the production of potent carbon equivalent emissions such as F-gases, HFC-23 and SF ₆
Renewable energy incentives and guarantees	Direct government incentives for industrial scale renewable energy applications such as heat pumps, biogas, or biomass
Feed-in tariffs	Tariff schemes that bolster renewable energy markets by offering a premium price for low-carbon electricity
Creation of low-carbon markets	Government created markets to offer premium prices for low-carbon products
Border-tariff adjustments	Restrictions placed on traded and imported carbon intensive goods, intended to reduce leakage
Sectoral agreements	The creation of roadmaps and sectoral plans to assist firms with decarbonization

Source: Compiled by the authors

climate mitigation [60]. A second option emerges for firms in debt, or those with limited capital available, via the use of energy service companies (ESCOs) or energy contracting, which are external firms or intermediaries that agree to finance and implement efficiency projects (or low-carbon retrofits) and then share the financial savings with the industry in question via a contract or arrangement [189,190]. A third option is to secure third-party financing, perhaps through green investment banks [191] or even, in some contexts, state investment banks [192] or multilateral development banks [193].

One report looked at *business models* for net-zero industry and suggested at least five that may benefit the food and beverages sector, namely [194]:

- Contract for difference carbon certificate strike prices. Under this approach, an emitter with carbon capture is paid (or refunded) the difference between a carbon dioxide strike price contractually agreed, tons abated, and the prevailing market certificate price. The displaced carbon is determined relative to an industry benchmark, with the costs of the program borne by taxpayers;
- Cost plus open book. Under this approach, an emitter is directly compensated through government grants for all properly incurred operational costs and any emitter capital investment is paid back with agreed returns;
- Tradeable tax credits. Under this approach, tax credits would offer reductions in the tax liability of firms that implement low-carbon measures, in tons abated, but the credits would tradeable;
- Regulated asset base (RAB) model. Under this approach, the model values assets used in the performance of a regulated function, for

example UK gas distribution, and sets tariffs to pass the costs of these assets on to consumers. The RAB model is said to be optimally applicable for hydrogen production for heat, where the cost recovery is through gas consumer bills.

- Tradeable carbon capture and sequestration (CCS) certificates + obligation: Tradeable CCS certificates are awarded, per tons of carbon abated, and obligated parties would be obliged to surrender a set number of these certificates, which may increase over time. This policy type might result in costs being borne by industry or taxpayers.

8.2. Policy instruments and mixes

The literature suggests an assortment of policy instruments or mixes, alongside business models, which can overcome some of the challenges to decarbonizing food and beverages, shown in Table 16.

In Europe, almost 98% of food and drink sector energy use and related carbon emissions are covered by the EU Emissions Trading System (EU ETS) and/or the Climate Change Agreement Scheme (CCA) [23]. Although imperfect, these *policies* have seen emissions in the sector plummet dramatically. The food and drink sector in the United Kingdom particularly has seen its absolute emissions decrease by 41% from 1990 to 2015, with reductions in energy consumption and carbon emissions plotted in Fig. 15. Steered by the EU ETS as well as national policy, the food and drink sector saw its energy consumption drop from more than 47 TWh to less than 34 TWh, or a sustained reduction in energy consumption by an average of 1.3% per year. Emissions reductions were driven primarily by:

- Switching from high-carbon fuels, such as coal and petroleum, to gas in onsite distributed heating;
- Relying more on electricity for processes, particularly that from natural gas (compared to coal or oil);
- The installation of more than 400 MW of combined heat and power capacity;
- Rigorous investments in energy efficiency.

Over this same timeframe, the sector has seen its gross value added to the economy *increase* by 13.8%. Even though some trends in the sector led to greater energy loads, such as automation, process control and growth in frozen foods, this was more than offset by improvements in energy efficiency, which were in turn driven by strong policy [23].

A variety of other policies have also driven efficiency and climate mitigation efforts, including (for the United Kingdom) an Energy Saving Opportunity Scheme, compliance with F-gas regulations, a Renewable Heat Incentive and beneficial feed-in tariffs and Renewables Obligations Certificates for firms wishing to adopt renewable energy [23].

A recent report on “net zero” industry suggests the need for further policy efforts—beyond emissions trading and those that already exist—across a mix of different areas [194]. It suggests investing in policies such as a premium price for low-carbon goods, with a low-carbon

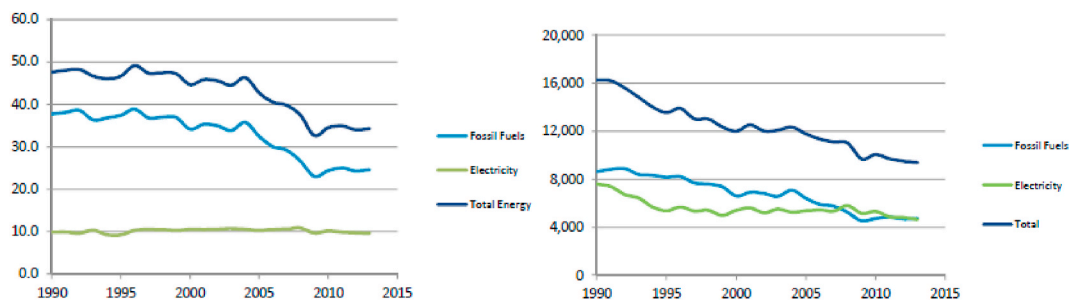

Fig. 15. Energy consumption (in TWh, left panel) and carbon dioxide equivalent emissions (in kT, right panel) in the food and drink sector of the United Kingdom, 1990–2015.

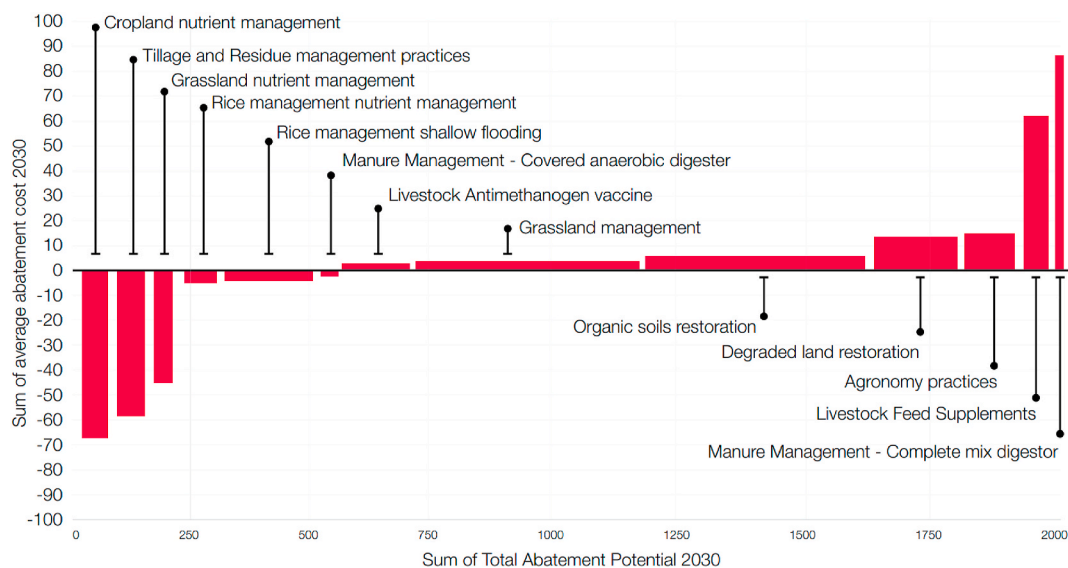

Fig. 16. Global greenhouse gas abatement curve for the agricultural sector.

market explicitly created by a government, and driven by some degree of public procurement, to split costs between taxpayers and governments. Border-tariff adjustments are proposed as a means of raising the price of higher carbon imported goods to help minimize the risks of leakage and signal to other manufacturing industries the need to decarbonize their supply chains. Finally, sectoral agreements are offered as stipulating pathways for firms to agree to phase out carbon according to a roadmap—a scheme said to work best in sectors with smaller numbers of firms. This could be a key towards tracking and ensuring the “carbon competitiveness” of different food products [95].

9. Gaps and future research agendas

A final finding from the systematic review related to what was not necessarily present, but what was missing. Here, we extrapolate five areas that we believe need addressed in future research.

9.1. Depiction of global decarbonization pathways and costs

As we stated earlier, global assessments of the full decarbonization of the food and beverage industry—via pathways, or even cost benefit analyses—did not arise within our review. Perhaps these are scant due to the fragmented nature of the industry and its subsystems, or the complexity in modeling the entire sociotechnical system. We have seen global carbon abatement curves for agriculture, but not for the entire food and beverage system. Still, these agricultural abatement curves suggest that some options are cost effective, such as cropland nutrient management or grassland management, whereas others such as agronomy or livestock feed supplements will have a net cost rather than benefit (see Fig. 16).

What is clearly needed are *whole systems* approaches that also map both *costs alongside expected benefits* as well as possible *pathways* for carbons reduction.

9.2. Identification and pursuit of cross-cutting solutions

Most of the assessments we collected of energy and carbon savings (Section 6.1) or cost and financial savings (6.2) were more narrowly focused on a single subsector (such as baking or dairy) or location (such as the USA, EU, or United Kingdom). Assessments of developing countries, or even the fast-growing BRICS economies of Brazil, Russia, India, China, and South Africa, were scarce, let alone coverage of least developed countries or those in sub-Saharan Africa. Perhaps this again

relates to the fragmentation of the industry, or the fact that such estimations are greatly dependent on local assumptions about a given process, firm, or subsector. Nevertheless, a few studies did attempt to identify *crosscutting* options that seemed common across different subsectors or countries, which we capture in Table 17.

Given its energy intensity and also that it uses highly potent greenhouse gases (such as halocarbons), refrigeration is a particularly powerful option for decarbonizing much of the food and beverages industry. One study across the entire food chain identified the ten best processes, excluding domestic systems, to save energy in the refrigeration cold-chain. As summarized by Table 18, it suggests the three largest areas of energy and carbon savings potential are retail display, kitchen refrigeration, and transport, although many levels of the cold-chain could achieve considerable savings with more efficient refrigeration techniques and devices [199].

When viewing Table 17 and Fig. 17, which builds on it, one clear attribute is its simplicity: it is a relatively short list of eight options that also ought to be comprehensible by most actors involved in the food system. Another is that all of the options are commercially available, many with track records of performance going back decades. Many are useful across multiple levels of the sociotechnical system and some, such as waste utilization, are possible across every level. Furthermore, the promise of these crosscutting interventions is that they can simultaneously affect multiple product groups and sectors. They can perhaps inform the need for global decarbonization pathways that we suggest are needed in Section 9.1. We thus believe more work on crosscutting options should be pursued.

9.3. Interconnection to other systems and industries

The global food and beverage system does not exist in isolation by itself, instead, like many other systems, it is layered or coupled to other sociotechnical systems [200]. Agriculture and food production would be the closest linked sociotechnical system although here we treat it as a subset of the global food and drink system. But interconnections to other prominent sociotechnical systems are shown in Fig. 18. The energy sociotechnical system, consisting of coal mines, power plants, transmission grids, heat networks, gas pipelines, and electricity distribution networks, provides much of the electricity, heat, steam, and raw fuels (natural gas, oil) needed for food and beverage production—with the food sociotechnical system as a whole accounting for roughly 30% of global energy consumption. The transportation system, inclusive of automobiles and delivery trucks but also roads, marine transport, ports

Table 17
Crosscutting options for the decarbonization of the food and beverage system.

Crosscutting option	Relevant for	Example(s)	Identified by
Refrigeration, chilling and freezing	Food supply and agriculture (especially aquaculture and fish), food and beverage manufacturing, food retail and distribution	Natural refrigerants, low- to no-Global Warming Potential refrigerants, energy-efficient refrigerators, chillers and freezers	[17, 195–198]
Energy efficiency	Food supply and agriculture, food and beverage manufacturing, food retail and distribution	Energy audits, energy management systems, efficiency upgrades of equipment, increased awareness and changes in practices	[36,56]
Fuel switching	Food supply and agriculture, food and beverage manufacturing, food retail and distribution	Substituting coal and oil with renewables or natural gas	[56]
Thermal management and process optimization	Food and beverage manufacturing	Better process management, optimization and recovery of combustion gases, preheating systems, condensers, heat exchangers, steam and drying systems	[36,70]
Low-temperature heat and steam recovery	Food and beverage manufacturing, food retail and distribution	Efficiency upgrades to boilers, electrifying sources of heat, substituting fossil fuels with biomass, biogas, natural gas or hydrogen, flue-gas heat recovery, variable speed drive motors	[31,56]
Combined heat and power, distributed generation or tri-generation	Food supply and agriculture, food and beverage manufacturing, food retail and distribution	Utilizing combined cycle gas turbines and other sources of energy to generate onsite heat, electricity, and steam simultaneously	[56]
Heat pumps	Food and beverage manufacturing	Relying on industrial scale heat pumps to upgrade heat from lower to higher temperatures or better utilize rejected waste heat, some can also provide refrigeration	[56]
Waste utilization and resource efficiency	Food supply and agriculture, food and beverage manufacturing, food retail and distribution, food consumption and end use	Better managing food waste flows and improving recycling, utilizing bioenergy or digesters to better capture the energy losses in waste streams	[31]

Source: Compiled by the authors

Table 18
Best estimate of the top ten food refrigeration processes for total energy and carbon savings in the United Kingdom.

Sector	Energy ('000 t CO2/year)	Saving (GWh/year %)	Total Saving (GWh/year)	
1 Retail display	3100–6800	5800–12,700	30–50	6300
2 Catering – kitchen refrigeration	2100	4000	30–50	2000
3 Transport	1200	4800	20–25	1200
4 Cold storage – generic	500	900	20–40	360
5 Blast chilling – (hot) ready meals, pies	167–330	309–610	20–30	180
6 Blast freezing – (hot) potato products	120–220	220–420	20–30	130
7 Milk cooling – raw milk on farm	50–170	100–320	20–30	100
8 Dairy processing – milk/cheese	130	250	20–30	80
9 Potato storage – bulk raw potatoes	80–100	140–190	~30	60
10 Primary chilling – meat carcasses	60–80	110–140	20–30	40

Source [199].

and harbors, and even airports and aviation, delivers and distributes raw materials, ingredients, and products. One study even estimated that, when including a full farm to fork analysis (agriculture to food processing and consumption), transportation accounts for almost half (48.5%) of emissions in the food production supply chain [4]. Similarly, in the United Kingdom, more than 98% of all foods within the country are distributed by road transport [3]. The chemicals sociotechnical system provides many of the fertilizers, pesticides, and preservatives needed for agriculture or food safety. The glass and plastics system provides bottles and packaging that protect both food and drinks—and it is telling that the food and drinks sector is responsible for about 70% of the total packaging consumed in the UK; the drinks sector alone uses over 4 million tons per year [42]. The retail shopping system consisting of not only supermarkets, shopping malls, but also cafes, catering services, and online shopping systems such as Amazon, which sells

innumerable food and beverage products and interact directly with consumers. Finally the global waste sector consisting of landfills, garbage trucks, recycling centers, and scrapyards handles many of the byproducts of the industry and discarded food at the end of its useful life.

These interconnections can create compelling dependencies, but also result in synergies that are rarely examined in research.

9.4. Appreciation of multi-scalar interventions and policies

A fourth area—connected in part to the cross-cutting complexities mentioned in Section 9.2, and the interconnection to systems in 9.3, is the multi-scalar nature of decarbonizing the industry. For example, one study in our sample did note that a multi-scalar approach to sustainability in the food industry would have to cut across the dimensions of food loss and waste, food packaging, energy consumption, food transport, water consumption, and waste management [12]. Another assessment of the global industry noted the need for interventions across a range of scales including seed manufacturing and fertilizers, insurance, farming, trading, manufacturing, retailing, and consuming [201]. This necessitates solutions that span raw materials to manufacturing to eating to handling waste streams. Table 19 shows these stages, and promising multi-scalar solutions to them, for three products of beer, pork, and soft drinks.

Moreover, as if the multi-scalar nature of solutions for beer, pork and soft drinks (alongside other products) was not complex enough, the particular impacts of their consumption will cut across sources of supply and demand, the other types of food they are eaten with, and even whether one eats at home or in a restaurant, as captured by this matrix in Fig. 19 [202].

This multi-scalar nature of food and drinks means, perhaps frustratingly, that multi-scalar solutions are needed as well, but these are difficult to implement across the various levels of the sociotechnical system. Moreover, very few of the policies we mention in Section 8.2 are truly multi-scalar. We urge more research on these fronts.

9.4. Research into the long-term impacts of COVID-19

In early 2020, a novel Coronavirus (COVID-19) emerged that triggered a global health pandemic with significant impacts on the energy sector [203]. While less often publicized than impacts on the energy sector, impacts of COVID-19 on the food and beverage industry are also

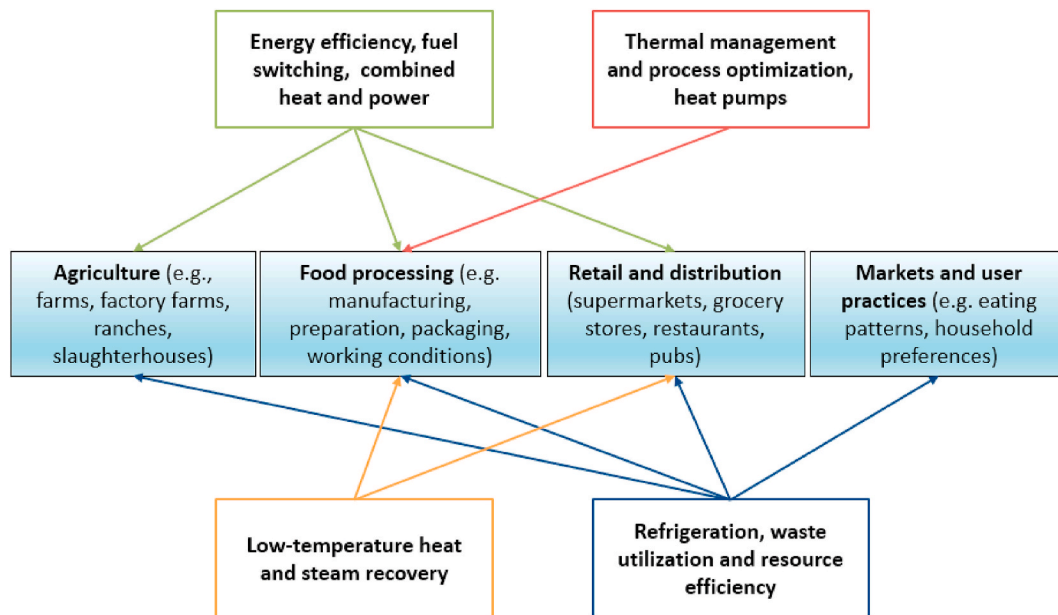

Fig. 17. Visualizing crosscutting options for the decarbonization of the food and beverage system.

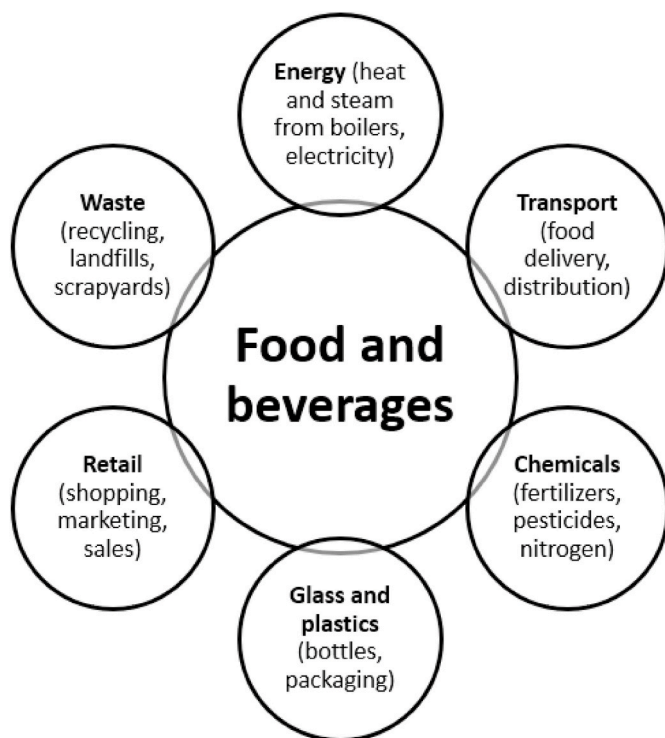

Fig. 18. Compelling interconnections of food and beverages to other socio-technical systems.

significant with considerations ranging from agricultural production to the rise of home food delivery and consumption aimed at avoiding social contacts that may contribute to disease spread [204–206]. One 2020 study even noted positive implications for sustainability, stating that:

In addition to the fact many Americans are telecommuting instead of driving to an office, more people are ordering groceries from home. Online grocery sales in the U.S. went up from US\$4 billion in March to a record-setting US\$7.2 billion in June ...

Table 19 Multi-scalar solutions to sustainability problems across three food and beverage products.

Part of the sociotechnical system	Beer	Pork	Soft drinks
Raw materials	<i>Barley farming:</i> Irrigation efficiency and better fertilizer management	<i>Pig breeding:</i> Organic farming principles and restrictions on human-edible grains	<i>Sugarcane farming:</i> Land use management, selective use of fertilizers
Food processing	<i>Beer production:</i> Increased water recapture, energy-efficient mashing and malting	<i>Meat processing:</i> Efficiency of equipment used in meat cutting, techniques in slaughtering	<i>Sugarcane refining:</i> Wastewater treatment and slurry and sludge management
Packaging and retail	<i>Glass bottling:</i> Sustainable packaging, refrigeration management	<i>Meat packing:</i> Efficiency of retail refrigeration and route optimization for transport delivery	<i>Plastic bottles:</i> Using recycled materials and avoiding polyethylene terephthalate (PET)
Consumer use	<i>Households:</i> efficiency of home refrigerators	<i>Households:</i> consume less meat to reduce footprint	<i>Households:</i> Consuming low- to non-sugar substitutes (e.g., diet soda)
End-of-use and waste	<i>Recovery:</i> Recycling of bottles	<i>Landfills:</i> anaerobic digestion of food waste	<i>Recovery:</i> recycling of bottles

Source: Authors modification of [201].

Because we tend to assume the lazy option is the less eco-friendly option, you might think people ordering groceries online is worse for the environment. But research has shown that having vehicles delivery orders to multiple households, which is how Amazon Fresh and other vendors operate, is significantly better for the environment than having many people in cars going to the store individually. Not only do these service vehicles delivery to several homes on one round trip, they also follow the fastest route to each home, which makes the whole system pretty efficient and can reduce the carbon emissions associated with

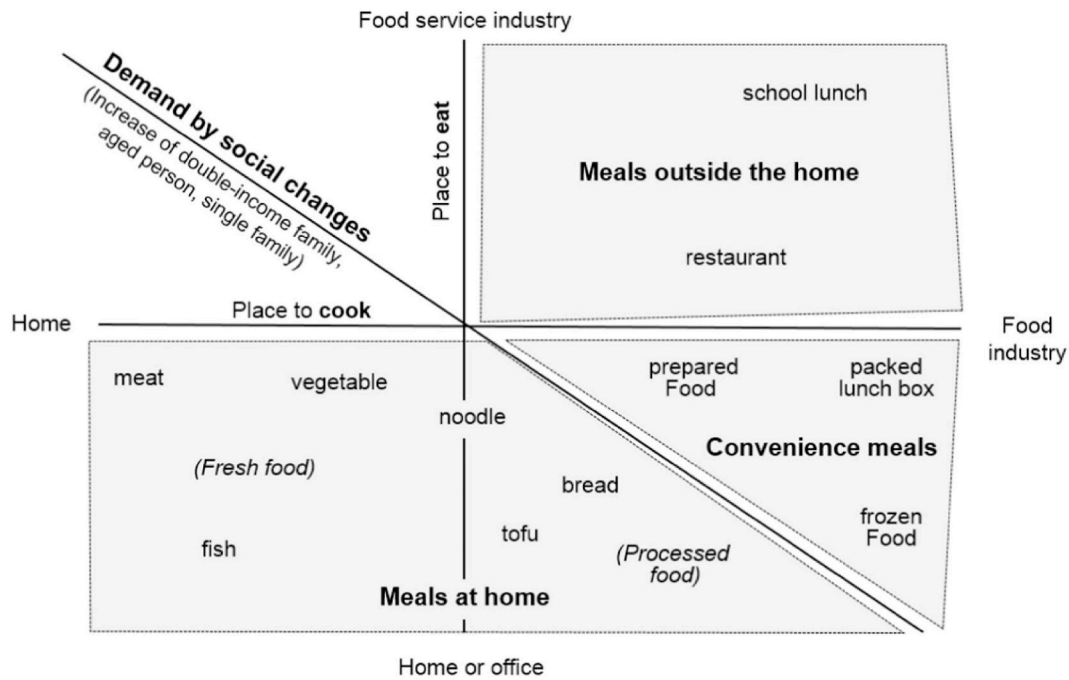

Fig. 19. A typology of food consumption by diet, location, and type of meal.

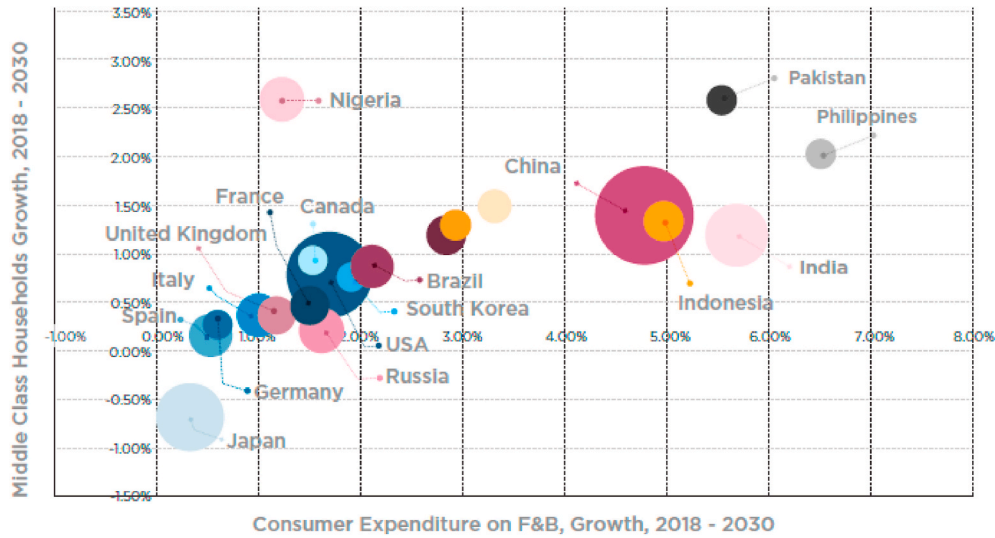

Fig. 20. Projected consumer expenditures on food and beverages in key markets from 2018 to 2030. Note: F&B refers to food and beverages.

grocery shopping by 25–75% [207].

Given the recent nature of the disease, research on this topic is only beginning to emerge but will nonetheless be an important research domain in the coming years. Indeed, adoption of several of the technologies and approaches discussed in this report, such as the deployment and use of robotic systems for food production and food delivery, may be greatly accelerated as a consequence of COVID-19.

9.5. Rigorous research on trade, illiberal states or non-Western societies

Our final suggestion relates to research on trade, or on diffusion to non-European or non-Western societies.

For example, it seems that the decarbonization of the global food and beverage industry is inextricably linked to the establishment of a high-quality, diversified and sustainable food development system that ensures the effective functioning of the global food supply chain. But very

little research in our sample addressed the issue of how global food trade can explicitly be decarbonized. Work on the “embodied emissions” of food or the emissions related to internationally traded food [208] would be apt in this regard.

Moreover, the bulk of studies in our sample looked at countries in Europe (especially the United Kingdom) or North America (especially Canada and the United States). And both those regions are the top two world markets for food and beverage consumption [38].

However, in the future trends will change, and the Asia Pacific region in particular is expected to become the world’s biggest consumer of food and beverages by 2030. Rates of consumption are exponentially increasing in emerging and developing countries, with growth in Sub-Saharan Africa, Asia, the Middle east and Latin America all outpacing North America. In Sub-Saharan Africa in particular, where a large base of consumers needs to spend most of its disposable income to ensure food security, the ratio of income-to-spending is especially high, as

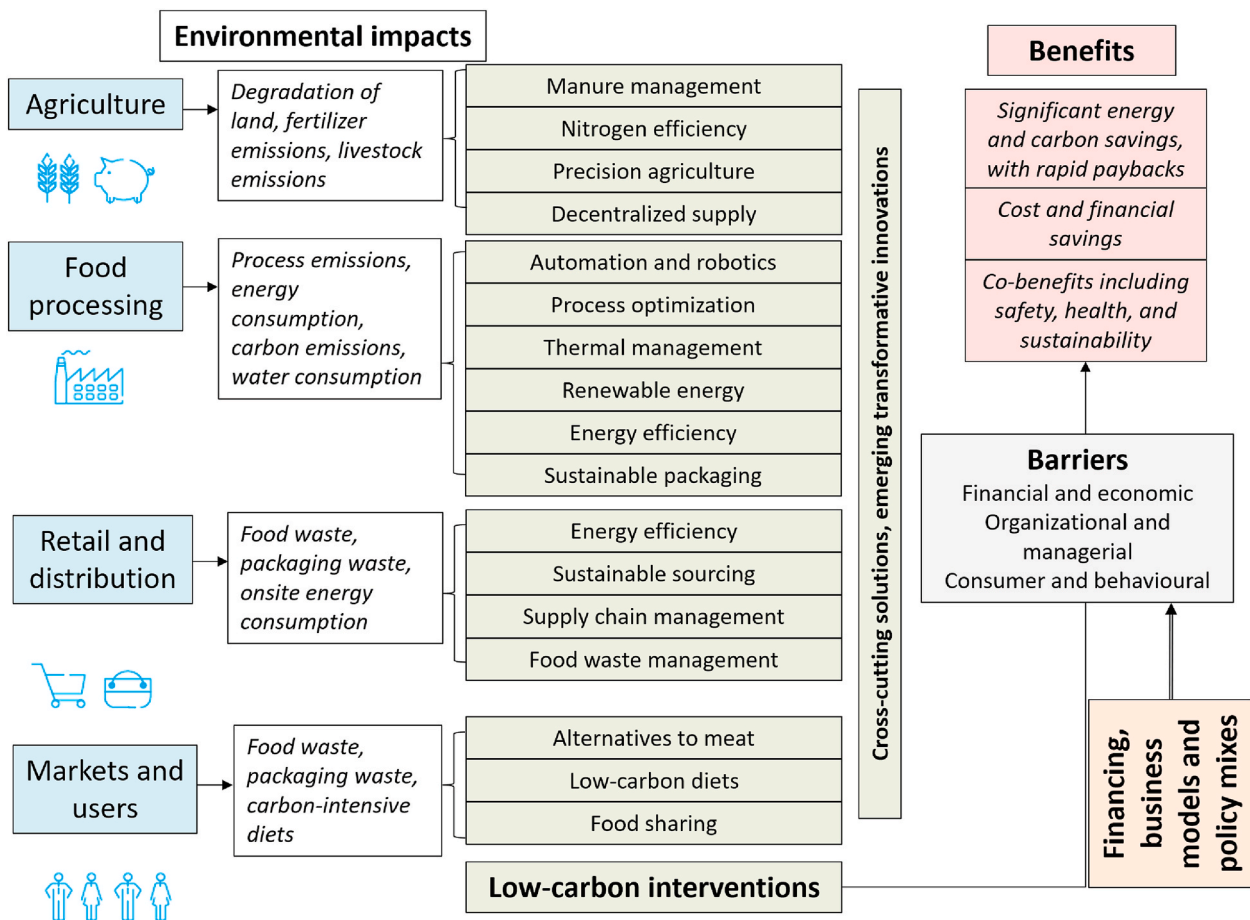

Fig. 21. Interventions, benefits, barriers and policies for decarbonizing the food and beverage sociotechnical system.

Fig. 20 indicates [38].

Research on food and beverage production, let alone decarbonization, is scarce in contexts such as Nigeria, China, Pakistan, the Philippines, India and Indonesia, a problem made more intricate by the very different governance systems, some of them illiberal or authoritarian, in many of those locations. What sorts of policy options and business models can work in these diverse contexts is a question currently unaddressed in the literature. Analytics are most lacking for these types of countries, and there is a paucity of data, even though this is where populations are most rapidly growing and where future food and drink demand will most increase.

10. Conclusion

There is perhaps no more intricate and important a sociotechnical system than food and beverages for providing humanity with safe, healthy products to eat and consume. This sociotechnical system, shown in Fig. 21, spans many scales and sectors including agriculture, food manufacturing and processing, food retailing and sales, and end use and waste. And yet this global system is currently and rapidly damaging the very social and natural systems that it utilizes to convert raw commodities and products into foodstuffs and beverages. Environmental impacts shown (in white) highlight the degradation of land, livestock emissions, industrial byproducts and waste, energy and carbon emissions, and food waste.

However, as complex and damaging as this sociotechnical system is, Fig. 21 also reveals an array of low-carbon interventions (shown in green) that can help mitigate emissions. This ranges from better manure management at farms to automation and robotics at factories that can help at improving energy efficiency and lowering emissions. These

proven technologies can coexist along with no less than 78 technologies with potentially transformative potential and crosscutting solutions such as steam management or the uptake of renewable energy. Eight crosscutting options (Section 9.2) are also promising.

While our review has indicated that barriers (shown in grey) exist at many levels to diffusing these options—financial and economic, organizational and managerial, consumer and behavioral—the benefits of doing so (shown in red) are vast. The system as a whole and the industries interconnected to it would benefit from truly massive reductions in energy use and carbon savings, financial savings with fairly rapid paybacks, a host of environmental co-benefits, as well as improvements in worker satisfaction and health. Thankfully, financing flows, business models, and particular policy mixes (shown in orange) can all be harnessed to tackle these barriers as well.

Apart from revealing how food and drink infrastructure, environmental impacts, low-carbon interventions, benefits, barriers, and policies all exist and coevolve in a system, our review also points the way towards six future research gaps. We call for work that better monetizes the costs and benefits of the global decarbonization of the sector; further identification of crosscutting solutions; possible synergies that arise by the nature of coupling and layering between the food and beverage system and other systems such as energy, transport, or plastics; the appreciation (and difficulty) of needing multi-scalar solutions; food security and scarcity in the time of COVID-19; and for more work on non-Western locations and cultures.

Perhaps when the research and business community begins to better address these concerns, many of the most serious problems plaguing the food and beverage system—prodigious energy losses, calamitous carbon emissions, extreme amounts of food waste—can be turned into promising opportunities. Although significant and multi-scalar barriers and

daunting challenges certainly remain, they need not prevail.

Declaration of competing interest

The authors declare that they have no known competing financial interests or personal relationships that could have appeared to influence the work reported in this paper.

Appendix I

Description of emerging and potentially transformative innovations for the food and beverage system (already discussed in section 5.5)

Innovation	Description
Urban horticulture	The growth of food, fruit and vegetables in urban or suburban environments
Advanced water reuse schemes	Utilize filtration, biological treatment and anaerobic digestion to clean and reuse water
Biochar application to soils	Employs biochar, a type of charcoal, to improve soil nutrients or crop yields
Vertical farming	A form of urban horticulture for the application of farming or agricultural techniques (e.g. hydroponics, aeroponics, or aquaponics) in buildings, skyscrapers or even underground
Photobioreactors	Integrated systems that convert sunlight to electrical energy but also grow algae as a biofuel, both forms of energy can be put to use to grow food
Algal biorefineries	Integrated systems that seek to reuse waste flows and algae to lower water and energy inputs for agriculture
Carbon capture and storage	Systems designed to capture and then sequester carbon dioxide from agricultural operations
Future food factories	Integrated food science, including nutrition, packaging and processing methods
Nanotechnology	The harnessing of nanostructures, nanodevices and nanoscale systems with agricultural objectives, e.g. nanoencapsulation of nutrients for product enrichment, or engineered nanomaterials that protect plants
Membrane emulsification	Technology based on the production of individual droplets utilizing specific pore size membranes which allow precision volumes
Extrusion technology	Forming of plastic/pliant or soft materials through a die in order to enhance ingredient mixing, cooking and shaping or forming
Food irradiation	Use of radiation to more efficiently clean prepackaged or bulk foodstuffs
Supercritical fluids	Uses high temperature and pressure fluids, such as CO ₂ , as more efficient solvents and cooling or heating agents
High pressure processing (HPP)	HPP is a non-thermal processing method that achieves pasteurization by applying hundreds of megapascals (MPa) of pressure to packaged food over a specified period of time. It is successfully implemented in a number of food processing installations.
Ohmic heating	Process where an electric current is passed through the food with the main purpose of heating it while decreasing the destructive thermal effects on food quality and nutritional value.
Ammonia refrigeration	Ammonia is an environmentally benign efficient refrigerant. There are some issues with leakage, but development of hermetically sealed compressors is underway and this will lead to increased implementation.
Supersonic steam shockwave	Novel heating and mixing technology based on the generation within a pipe of a steam shockwave with supersonic velocities. The technology is effective in the heating of mixtures such as pastes and sauces.
Remote condition monitoring	Remote machinery condition monitoring refers to systems that constantly monitor key machine parameters and provide early indication by email/text of performance deterioration, allowing for a planned intervention before failure.
Pulsed light/ultraviolet light in packaging	An emerging non-thermal technology consisting of short time pulses of broad spectrum white light for decontamination of food services and food packages.
Cold plasma	An antimicrobial treatment being investigated for application to fruits vegetables and other foods with fragile surfaces. Cold plasma is a term describing ionized gas flows at ambient temperatures. This distinguishes them from other plasmas which can occur at hundreds or thousands of degrees above ambient.
Aseptic filling	Process of packing a sterile food product into a sterilized package in a way which maintains overall sterility of the process.
Robotics and automation	Programmable, multi-functional manipulator machines designed to move materials, parts, tools or specialized devices for the performance of a variety of tasks such as the handling of standardized products such as boxes, pallets and packages or production line work
Machine vision	The ability of machines to interpret and extract information from visual data. Enables automation of tasks that traditionally require human vision, such as equipment inspection or object recognition; it also enables machines to identify and quantify visual information that is imperceptible to the human eye.
Impingement air flow freezing	A technique that reduces the thermal boundary around food and results in faster freezing than conventional equipment allows.
Vacuum cooling	Cooling technique that enhances the evaporation rate of the contained moisture.
Microwave heating	Radiative heating process with potential advantages over conventional heating given the ability to penetrate deeply into food, even those that are highly viscous.
Air cycle refrigeration	Refrigeration that utilizes air as a refrigerant and is thus environmentally benign.
Hydrodynamic cavitation	A process in which high energy is released in a flowing liquid upon bubble implosion due to decrease and subsequent increase in local pressure
3D food printing	The process of manufacturing food products using a variety of additive manufacturing techniques
Advanced starter cultures	Genetically modified microbial preparations used to increase the efficiency of fermentation
Advanced surfactants	Modified compounds that act as less toxic surfactants or those with more effective and efficient surface tension modification properties
Superheated steam drying	Advanced dehydration techniques to extend the shelf life of dried fruit or instant coffee
Biosensors	Sensors with a biological recognition (sensing) element (such as enzyme, antibody, receptor or microorganisms)
Hurdle technology	Use of low-level chemicals or the combination of preservation techniques to enhance the quality of food by ensuring pathogens are eliminated or controlled.
Online food safety and quality indicator	Remote system of checking and analyzing the safety of food processing equipment and the quality of food and drink accessible via a network connection.
Pulsed ultraviolet light in food processing	A low-energy alternative to pasteurization and/or continuous light treatments for solid and liquid foods.
Pulsed electric field in food processing	Processing of a liquid food or other pumpable product by passing it through a chamber where it is subject to a short pulse of very high voltage that kills microorganisms by disrupting their cell membranes.
Neutral electrolyzed water	Used in the treatment of foodstuffs that present surface contamination challenges such as salad components.
Ozonated water	

(continued on next page)

(continued)

Innovation	Description
	Used to produce on demand water containing four ppm of ozone, which is then used as a cleaning/sanitizing agent for surfaces and/or fruit and vegetable products.
Exchanger fouling detection	Methods of detecting unwanted deposits on heat transferring surfaces, which lead to reduced heat transfer and increased heat transfer resistance. Detection can be via pressure drop, temperature and heat transfer parameters or electrical parameters.
Continuous dense phase carbon dioxide	A continuous, non-thermal processing method for heat sensitive foods preserves quality, nutrients while inactivating microorganisms and enzymes in liquid foods.
Infrared heating	Heating in a range of food processing applications including drying, baking, roasting and blanching with the objective of reducing processing time and energy losses and extending the shelf life of the food products
Radio frequency heating	Radio frequency heating is a radiative technique utilizing electromagnetic radiation of longer wavelength than microwave, which enables better penetration of larger items of food.
Hyperspectral imaging	Combines conventional imaging and spectroscopy to attain both spatial and enhanced spectral information from an object. It is an analytical tool for nondestructive food analysis.
Bernoulli grippers	Works on the principle that an aircraft wing utilizes to create lift. In food applications it allows the lifting of food stuffs without touching the food: thus there is no residue left contaminating the gripper.
Soluble gas stabilization	Method to extend the shelf-life of foods by dissolving CO ₂ into packages prior to packaging,
Laser sealing	A non-contact sealing technique for thin, plastic lidding films, used for food packaging. It does not require bespoke tooling to hold the package components in close proximity and under pressure whilst the seal is formed, reducing sealing machine tooling costs.
Microsieves	A micro-filtration membrane with hole sizes of only 0.1 μm (0.0000001 m) used for filtration of drink and dairy products and also make the products insensitive to fouling.
Coflux	Innovative batch reactor that has a thin, variable cooling/heating jacket. It has more responsive temperature controls, better energy efficiency and no “dead spots” in the heating transfer surfaces.
Conditioned gas cooling	Method of cooling based upon condensing gases within cooling towers and using air atomizing nozzles to cool down products.
Pulsed electric field in pasteurization	A non-thermal method for pasteurizing liquids. Enzymes and microorganisms can be inactivated without affecting the color, flavor and nutrients of the food
Pulsed electric field in cooking	Used in food preservation to maintain its “fresh appearance” with only minor change in nutritional composition. A short burst of high voltage electricity is applied to the food. It can be carried out at ambient or refrigeration temperatures.
Foreign body detection by spectrometry	Method of detecting items that should not be in food by analysis of the mass of the products to detect any objects that are at not at the density of the intended product.
Magnetic refrigeration	Refrigeration based upon the magnetocaloric effect; the change in temperature of a suitable material is caused by exposing the material to a changing magnetic field.
Modified atmosphere packaging	Technique to use modified atmospheres to extend shelf-life of fresh produce by limiting the exchange of respiratory gases in packages made of semi permeable plastic films.
Electroosmotic dewatering	Using electric fields to channel liquid and remove water
Thermoacoustic heat engines	Converts thermal energy to acoustic energy via heat exchangers to improve efficiency of heat recovery
Thermo-Catalytic Reforming	Process of valorization that converts food waste or other waste into energy vectors such as hydrogen or biochar
Edible food packaging and coatings	The use of coverings or packaging that consumers can eat with their product
Drones and automated vehicles for food delivery	Utilization of automated or remotely piloted and unmanned vehicles to deliver food and/or collect waste
Large-scale hydroponic produce	Produce grown locally and hydroponically in the store in bulk
Fully automated food management	The use of advanced artificial intelligence to manage food stocks, especially the most perishable produce.
Single homogenization/mixing (SHM) valve	Homogenization process that saves up to 80% of energy compared to conventional homogenizing techniques by the deforming effect of the elongational flow in the orifice valve inlet.
Sonication	Process of transmitting soundwaves through a media, which results in extreme pressures and temperatures, resulting in intense cleaning power that sterilizes by destroying all harmful microorganism membranes. There are two food processing applications of sonication. Sonication of various liquids make processes like homogenization and emulsification fast and easy. It allows for the break down of larger molecules in a solution, producing uniformity and stability. Sonication is used for processing and packaging meat and fish. Using sonication in this solid medium aims at gaining stability and extending product shelf lives. The bacteria and enzymes that cause spoilage are destroyed and deemed incapable of causing damage.
Heat free shrink wrapping	Plastic packaging that does not use heat to adhere to the product. It is useful for situations where using high heats are not suitable.
Acoustic refrigeration	Refrigeration which operates by using sound waves and a non- flammable mixture of inert gas (helium, argon, air) to produce cooling. It offers the development of efficiency and cost advantages over vapor compression systems.
Electrocaloric refrigeration	Refrigeration using a material that shows a reversible temperature change under an applied electric field.
Optical refrigeration	Refrigeration using the laser cooling of solids to cryogenic temperatures.
Hydraulic refrigeration	Refrigeration utilizing a gas vapor-compression system that entrains refrigerant vapor in a down-flowing stream of water. The pressure head of the water compresses and condenses the refrigerant.
Continuous oscillatory baffle reactor	Highly efficient mixing method in comparison with traditional stirred batch reactors. An oscillatory motion to the fluid (or baffle) creates eddies, which lead to highly efficient mixing in comparison with traditional stirred batch reactors.
Spinning disk	Method of spraying a liquid with a dish shaped rotating stainless steel disc. By enclosing the spinning disc with a metal cover with an adjustable aperture, a precision spray pattern can be focused on the required area of application.
Electric arc discharging	The electrical breakdown of gases for improved cleaning or sanitation
Microfluidics	Assisting technology that can extend the shelf life of products through the utilization of mixtures of air and gases in product packaging
Apps for food sharing	Applications for phones or computers that enable real-time sharing of food, often in urban areas
Organic farming	A whole systems approach to food production that better maintains soil quality and reduces environmental burdens
Meat substitutes	Soy or plant based alternatives to animal based proteins
Zero-carbon readymade meals	Entire meals certified to be net zero carbon
Robotic chefs	Fully automated robots that cook and prepare food
Fully automated smart homes	Homes that continuously and automatically manage food supply in the home

Source: Authors, with references provided in the main body of the text.

References

- [1] Schramski JR, Woodson CB, Brown JH. Energy use and the sustainability of intensifying food production. *Nat Sustain* 2020;3:257–9. <https://doi.org/10.1038/s41893-020-0503-z>.
- [2] Clark Michael A, et al. Global food system emissions could preclude achieving the 1.5° and 2°C climate change targets. *Science* 06 Nov 2020;370(6517):705–8.
- [3] Latha-Sabur Alia, et al. Mapping energy consumption in food manufacturing. *Trends Food Sci Technol* 2019;86:270–80.

- [4] Jagtap Sandeep, et al. Real-time data collection to improve energy efficiency: a case study of food manufacturer. *J Food Process Preserv* 2019:e14338. 00.
- [5] Pattara Claudio, et al. Carbon footprint as an instrument for enhancing food quality: overview of the wine, olive oil and cereals sectors. *J Sci Food Agric* 2017; 97:396–410.
- [6] Monteiro CA, et al. Ultra-processed products are becoming dominant in the global food system. *Obes Rev* 2013;14(Suppl. 2):21–8.
- [7] Caitlin Scott, Sustainably sourced junk food? Big food and the challenge of sustainable diets, *Global Environ Polit* 18:2, May2018,doi:10.1162/glep_a_00458.
- [8] Smith Emma, et al. Should we tax unhealthy food and drink? *Proc Nutr Soc* 2018; 77:314–20.
- [9] Stephen D. Sugarman and nirit Sandman, fighting childhood obesity through performance-based regulation of the food industry. *Duke Law Journal*, Apr. 2007;56(6):1403–90.
- [10] National Academies of Sciences, Engineering, and medicine. Reducing Impacts of Food Loss and Waste: Proceedings of a Workshop. Washington, DC: The National Academies Press; 2019. <https://doi.org/10.17226/25396>.
- [11] Wasserman Arlin. Recipe for a better tomorrow: a food industry perspective on sustainability and our food system. *J Hunger Environ Nutr* 2009;4(3–4):446–53. <https://doi.org/10.1080/19320240903329063>.
- [12] Ayten Aylın Alsaffar. Sustainable diets: the interaction between food industry, nutrition, health and the environment. *Food Sci Technol Int* 2016;22(2):102–11.
- [13] Ellen MacArthur Foundation. Cities and Circular Economy for Food. 2019.
- [14] Klemeš Jiri, Perry Simon J. Process optimisation to minimise energy use in food processing. *Handbook of waste management and Co-product recovery in food processing*, ume 1. Woodhead Publishing Series in Food Science, Technology and Nutrition; 2007. p. 59–89.
- [15] Setyawan Dhani. Energy efficiency in Indonesia's manufacturing industry: a perspective from Log Mean Divisia Index decomposition Analysis. *Sustainable Environment Research* 2020;30:12. <https://doi.org/10.1186/s42834-020-00053-9>.
- [16] Bhadbhade Navdeep, Patel Martin K. Analysis of energy efficiency improvement and carbon dioxide abatement potentials for Swiss Food and Beverage sector, *Resources, Conserv Recycl* 2020;161:104967.
- [17] James SJ, James C. The food cold-chain and climate change. *Food Res Int* 2010; 43:1944–56.
- [18] Park Yong Shin, et al. A novel life cycle-based principal component analysis framework for eco-efficiency analysis: case of the United States manufacturing and transportation nexus. *J Clean Prod* 2015;92:327–42.
- [19] Behavioral, Social Sciences and Education, National Academies of Sciences, Engineering, and medicine. Science Breakthroughs to Advance Food and Agricultural Research by 2030. Washington, DC: The National Academies Press; 2019. <https://doi.org/10.17226/25059>.
- [20] Behavioral, Social Sciences and Education, National Academies of Sciences, Engineering, national aca daenmd iEmse ofdi cSciences, engineering, and medicine. Science Breakthroughs to Advance Food and Agricultural Research by 2030. Washington, DC: The National Academies Press; 2019. <https://doi.org/10.17226/25059>.
- [21] Tassou Savvas A, et al. Energy demand and reduction opportunities in the UK food chain. Proceedings of the Institution of Civil Engineers; Energy 167 August 2014 Issue EN3. p. 162–70. <https://doi.org/10.1680/ener.14.00014>.
- [22] Europe FoodDrink. Data and Trends EU Food and Drink Industry 2018. 2018.
- [23] Department for Business, Energy & Industrial Strategy (BEIS). Food and Drink Joint Industry - Government Industrial Decarbonisation and Energy Efficiency Roadmap Action Plan. London. October 2017.
- [24] National Academies of Sciences, Engineering, and Medicine. Innovations in the Food System: Exploring the Future of Food: Proceedings of a Workshop. Washington, DC: The National Academies Press; 2020. <https://doi.org/10.17226/25523>.
- [25] Scottish Government. Skills Investment Plan: For Scotland's food and drink sector. Glasgow. December. SDS-1316-Dec16. 2016.
- [26] Klemeš Jiri, et al. Methods to minimise energy use in food processing. In: *Handbook of water and energy management in food processing* Woodhead publishing. Series in food science, technology and nutrition; 2008. p. 136–99.
- [27] Gehlhar Mark, Regmi Anita. Factors Shaping Global Food Markets. *New Directions in Global Food Markets/AIB-794 Economic Research Service*. USDA; 2005.
- [28] IMAP. Food and Beverage Industry: Global Report. 2010 [An IMAP Consumer Staples Report].
- [29] Tassou SA, et al. Modelling cold food chain processing and display environments. In: *Modeling food processing operations*. Woodhead Publishing Series in Food Science, Technology and Nutrition; 2015. p. 185–208.
- [30] Cushman & Wakefield. The Global Food and Beverage Market: What's On the Menu? CUS100772 04/17. 2017.
- [31] Chowdhury Jahedul Islam, et al. Reducing industrial energy demand in the UK: a review of energy efficiency technologies and energy saving potential in selected sectors. *Renew Sustain Energy Rev* 2018;94:1153–78.
- [32] BDO. Food and Drink Report 2018 Edition: Moving Towards a More Productive, Post-Brexit World. London. BDO International; 2018.
- [33] Food, Drink Federation. The Food and Drink Industry: Economic contribution and growth opportunities. London. June 2017.
- [34] Food, Drink Research Network. Ensuring Sustainable Employment and Competitiveness in the EU Food and Drink Industry: Meeting the Challenges of the Labour Market. A joint initiative of the Social Partners in the EU Food and Drink Industry. 2012. VS/2012/0239.
- [35] Roibas Laura, et al. Determination of the carbon footprint of all Galician production and consumption activities: lessons learnt and guidelines for policymakers. *J Environ Manag* ;198:289–99.
- [36] Aranda-Uson Alfonso, et al. Energy consumption analysis of Spanish food and drink, textile, chemical and non-metallic mineral products sectors. *Energy* 2012; 42:477–85.
- [37] Gondia Sokhna Seck. Heat recovery using heat pumps in non-energy intensive industry: are Energy Saving Certificates a solution for the food and drink industry in France? *Appl Energy* 2015;156:374–89.
- [38] Euromonitor International. The World of Good Food: Global Industry Outlook Report 2019. Brussels. 2019.
- [39] FAO. Global food losses and food waste – Extent, causes and prevention. Rome. 2011.
- [40] Fearnle Andrew, Duffy Rachel, Hughes David. Concepts of collaboration: supply chain management in a global food industry. In: Sharples Liz, Ball Stephen, Eastham Jane F, editors. Food and drink supply chain management - issues for the hospitality and retail sectors. Butterworth-Heinemann; 2001. p. 55–89. 978-0-7506-4762.
- [41] R. Andrew Wilbey, Dairy technology: a UK perspective on its past, present and future, *International Journal of Dairy Technology*, Vol 70, No 4 November 2017 459–468.
- [42] Gujba H, Azapagic A. Carbon footprint of beverage packaging in the United Kingdom. In: Finkbeiner M, editor. Towards life cycle sustainability management. Springer; 2011. https://doi.org/10.1007/978-94-007-1899-9_37.
- [43] Eriksson Ola, et al. Life cycle assessment of Swedish single malt whiskey. *J Clean Prod* 2016;112:229–37.
- [44] Trollman Hana, et al. Ecologically embedded design in manufacturing: legitimization within circular economy. *Sustainability* 2020;12:4261. <https://doi.org/10.3390/su12104261>.
- [45] Grant Maria J, et al. A typology of reviews: an analysis of 14 review types and associated methodologies. *Health Inf Libr J* 2009;26:91–108.
- [46] Haddaway NR, Woodcock P, Macura B, Collins A. Making literature reviews more reliable through application of lessons from systematic reviews. *Conserv Biol* 2015;29(6):1596–605.
- [47] Petticrew M, Roberts H. *Systematic Reviews in the Social Sciences: A Practical Guide*. Malden, 1044 MA: Wiley-Blackwell; 2006.
- [48] Sorrell S. Improving the evidence base for energy policy: the role of systematic reviews. *Energy Pol* 2007;35:1858–71. 2007.
- [49] Sovacool BK, Axsen J, Sorrell S. Promoting novelty, rigor, and style in energy social science: towards codes of practice for appropriate methods and research design. *Energy Research & Social Science* 2018;45:12–42.
- [50] Pereira Joana Portugal, Slade Raphael. *Systematic Approaches to Assessments*. IPCC Working Group III TSU. March 7. 2019.
- [51] Sovacool BK, Hess DJ. Ordering theories: typologies and conceptual frameworks for sociotechnical change. *Soc Stud Sci* October, 2017;47(5):703–50.
- [52] Hess DJ, Sovacool BK. Sociotechnical matters: reviewing and integrating science and technology studies with energy social science. *Energy Research & Social Science* 2020;65(July):1–17. 101462.
- [53] Lowe Philip, Phillipson Jeremy, Lee Richard P. Socio-technical innovation for sustainable food chains: roles for social science. *Trends Food Sci Technol* 2008;19 (Issue 5):226–33.
- [54] Hinrichs CC. Transitions to sustainability: a change in thinking about food systems change? *Agric Hum Val* 2014;31:143–55.
- [55] Cook Christopher D. *Diet for a Dead Planet: How the Food Industry is Killing Us*. New York: New Press; 2004.
- [56] Griffin Paul W, et al. Industrial energy use and carbon emissions reduction: a UK perspective. *WIREs Energy Environ* 2016;5:684–714. <https://doi.org/10.1002/wene.212>.
- [57] Stehfest Elke, Bouwman Lex, Detlef P, van Vuuren, Michel G, den Elzen J. Bas eckhout, and Pavel Kabat, "climate benefits of changing diet. *Climatic Change* July 2009;95(1–2):83–102.
- [58] Brown MA, Sovacool BK. *Climate Change and Global Energy Security: Technology and Policy Options*. Cambridge: MIT Press; 2011.
- [59] Mohr Noam. *Global Warming Strategy A New*. How environmentalists are overlooking vegetarianism as the most effective tool against climate change in our lifetimes. *EarthSave International Report* 2005. August.
- [60] Department of Energy and Climate Change and the Department for Business, Innovation and Skills. *Industrial Decarbonisation & Energy Efficiency Roadmaps to 2050: Food and Drinks*. London. March 2015.
- [61] James S, James C. Improving energy efficiency within the food cold-chain, Food Refrigeration and Process Engineering Research Centre (FRPERC), The Grimsby Institute of Further & Higher Education. GIFHE; 2006.
- [62] Tasou SA, et al. Energy consumption and conservation in food retailing. *Appl Therm Eng* February 2011;31(2–3):147–56.
- [63] Girardet Herbert, Mendonca Miguél. *A Renewable World: Energy, Ecology, Equality* (London: Green Books; 2009. p. 187.
- [64] Kissinger M. International trade related food miles—The case of Canada. *Food Pol* 2012;37(2):171–8.
- [65] World Health Organization. *Fuel for Life: Household Energy and Health*. Geneva: WHO; 2006.
- [66] Practical Action, *Poor People's Energy Outlook*. (Rugby, UK: Practical Action Publishing). 2010.
- [67] Velumail T. Regional Context for Improving Access to Energy: Energy for Creating and Sustaining Livelihoods, Presentation to the United Nations Economic and Social Commission for Asia and the Pacific (UNESCAP) and International Fund for Agricultural Development (IFAD) Inception Workshop on "Leveraging Pro-Poor

- Public-Private-Partnerships (5Ps) for Rural Development". Bangkok, Thailand: United Nations Convention Center; 2011. September 26.
- [68] Gaye Amie. "Access to Energy and Human Development," Human Development Report 2007/2008. United Nations Development Program Human Development Report Office Occasional Paper; 2007.
- [69] Robert E. Koppa and Denise L. Mauzerall, "Assessing the climatic benefits of black carbon mitigation," Proceedings of the National Academies of Science (June 21, 2010), pp. 11704–11708.
- [70] Compton Marc, et al. Food processing industry energy and water consumption in the Pacific Northwest. *Innovat Food Sci Emerg Technol* 2018;47:371–83.
- [71] Meyers Steven, et al. Energy efficiency, carbon emissions, and measures towards their improvement in the food and beverage sector for six European countries. *Energy* 2016;104:266–83.
- [72] Wang Lijun. Energy efficiency technologies for sustainable food processing7. *Energy Efficiency*; 2014. p. 791–810.
- [73] Evans Judith. Minimising energy consumption associated with chilling, refrigerated storage and cooling systems in the food industry. *The Handbook of Water and Energy Management in Food Processing*. Woodhead Publishing Series in Food Science, Technology and Nutrition; 2008. p. 449–80.
- [74] Mikulić Hrvoje, et al. Flexible Carbon Capture and Utilization technologies in future energy systems and the utilization pathways of captured CO₂. *Renew Sustain Energy Rev* 2019;114:109338.
- [75] Boehm Rebecca, et al. A comprehensive life cycle assessment of greenhouse gas emissions from U.S. Household food choices. *Food Policy Volume August 2018*; 79:67–76.
- [76] Konstantas Antonios, et al. Environmental impacts of chocolate production and consumption in the UK. *Food Res Int* 2018;106:1012–25.
- [77] Ximena C. Schmidt Rivera and Adisa Azapagic, Life cycle environmental impacts of ready-made meals considering different cuisines and recipes. *Sci Total Environ* 2019;660:1168–81.
- [78] EPA, Global Anthropogenic Non- CO₂ GHG Emissions: 1990-2020. EPA, Inventory of U.S. Greenhouse Gas Emissions and Sinks.
- [79] U.S. Department of Agriculture (USDA). Energy estimator, energy consumption awareness tool. Available at, <http://nfat.sc.egov.usda.gov/Help.aspx>; 2006.
- [80] Victor DG, Geels FW, Sharpe S. Accelerating the Low Carbon Transition: The Case for Stronger, More Targeted and Coordinated International Action. 2019.
- [81] U.S. Department of Agriculture (USDA). Precision agriculture: information technology for improved resource use. Available at, <http://www.ers.usda.gov/publications/agoutlook/apr1998/ao250f.pdf>; 1998.
- [82] Lovarelli Daniela, Bacenetti Jacopo, Guarino Marcella. A review on dairy cattle farming: is precision livestock farming the compromise for an environmental, economic and social sustainable production? *J Clean Prod* 2020;262:121409.
- [83] Gimenez Escalante P and Rahimifard S. A methodology to assess the suitability of food processing technologies for distributed localised manufacturing. *Sustainability*, 11(12): 3383.
- [84] Luan C, Zhang M, Fan K, Devahastin S. Effective pretreatment technologies for fresh foods aimed for use in central kitchen processing. *J Sci Food Agric* 2021; 101:347–63. <https://doi.org/10.1002/jsfa.10602>.
- [85] Sheppard Phil, et al. Synergies in the co-location of food manufacturing and biorefining. *Food Bioprod Process* 2019;117:340–59.
- [86] Caldeira Carla, et al. Sustainability of food waste biorefinery: a review on valorisation pathways, techno-economic constraints, and environmental assessment. *Bioresour Technol* 2020;312:123575.
- [87] Siqueiros Eric, Lamidi Razaq O, Pathare Pankaj B, Wang Yaodong, Roskilly AP. Energy recovery from brewery waste: experimental and modelling perspectives. *Energy Procedia* 2019;161:24–31.
- [88] Simpson RJ, et al. Automatic control of batch thermal processing of canned foods. In: *Robotics and automation in the food industry current and future technologies*. Woodhead Publishing Series in Food Science, Technology and Nutrition; 2013. p. 420–40.
- [89] Simpson R, et al. Advances with intelligent on-line retort control and automation in thermal processing of canned foods. *Food Contr* 2007;18:821–33.
- [90] Breaux Randy. Automation in the food industry: past, present and future. *Food Processing Journal* August 21, 2018.
- [91] Thomas Andrew, et al. Smart systems implementation in UK food manufacturing companies: a sustainability perspective sustainability, vol. 10; 2018. p. 4693. <https://doi.org/10.3390/su10124693>.
- [92] Gonzalez Viejo Claudia, et al. Development of a low-cost e-nose to assess aroma profiles: an artificial intelligence application to assess beer quality. *Sensor Actuator B Chem* 1 April 2020;308:127688.
- [93] Skladal Petr. Smart bioelectronic tongues for food and drinks control. *Trends Anal Chem* 2020;127:115887.
- [94] Lee W, Okos MR. Sustainable food processing systems Path to a zero discharge: reduction of water, waste and energy. *Proc. Food Sci.* 2011;1:1768–77.
- [95] Poynton R. Step change towards net zero environmental impact in food processing: the closed-loop approach. *Handbook of waste management and Co-product recovery in food processing*, ume 2; 2009.
- [96] Muster-Slawitsch Bettina, et al. Application of an advanced pinch methodology for the food and drink production. *WIREs Energy Environ* 2014;3:561–74. <https://doi.org/10.1002/wene.117>.
- [97] Mukherjee Sanjay, Asthana Abhishek, Howarth Martin, McNeill Ryan, Frisby Ben. Achieving operational excellence for industrial baking ovens. *Energy Procedia* 2019;161:395–402.
- [98] McKinsey & Company. Decarbonization of industrial sectors: the next frontier. Boston: June; 2018.
- [99] Reay David. Heat recovery in the food industry, *Handbook of Water and Energy Management in Food Processing* Woodhead Publishing Series in Food Science, Technology and Nutrition. 2008. p. 544–69.
- [100] Madlener Reinhard, Wickart Marcel. Diffusion of cogeneration in Swiss industries: economics, technical change, field of application, and framework conditions. *Energy Environ* 2004;15(No. 2):223–37.
- [101] IRENA. Renewable Energy Options for the Industry Sector: Global and regional Potential until 2030. UAE: IRENA; 2015.
- [102] Plemper George S, et al. Climate change levy and its application within the dairy industry. *International Journal of Dairy Technology* 2 May 2003;56(No):68–75.
- [103] Barron-Gafford GA, Pavao-Zuckerman MA, Minor RL, et al. Agrivoltaics provide mutual benefits across the food–energy–water nexus in drylands. *Nat Sustain* 2019;2:848–55. <https://doi.org/10.1038/s41893-019-0364-5>.
- [104] Maraseni TN, Mushtaq S, Reardon-Smith K. Integrated Analysis for a Carbon- and water-constrained Future: an assessment of drip irrigation in a lettuce production system in Eastern Australia. *J Environ Manag* 2012;111:220–6.
- [105] Burney Jennifer A, et al. Smallholder irrigation as a poverty alleviation tool in sub-Saharan Africa. *World Dev* 2012;40(No. 1):110–23.
- [106] Solar Electric Light Fund. Empowering Women with Solar Irrigation: The Solar Market Garden Enhances Food Security in Benin. West Africa (Washington, DC: SELF; 2012.
- [107] Cagno Enrico, et al. Drivers for energy efficiency and their effect on barriers: empirical evidence from Italian manufacturing enterprises10. *Energy Efficiency*; 2017. p. 855–69.
- [108] Sheppard Phil, Rahimifard Shahin. Improving energy efficiency in manufacturing using peer benchmarking to influence machine design innovation. *Clean Technol Environ Policy* 2019;21:1213–35.
- [109] Henningsson Stefan, et al. Minimizing material flows and utility use to increase profitability in the food and drink industry. *Trends Food Sci Technol* 2001;12: 75–82.
- [110] Nicola Cantore. Factors affecting the adoption of energy efficiency in the manufacturing sector of developing countries10. *Energy Efficiency*; 2017. p. 743–52.
- [111] Rooney Michael L. Introduction to active food packaging technologies. *Innovations in Food Packaging* Food Science and Technology. London: Academic Press; 2005. p. 63–79.
- [112] Skinner GA. Smart labelling of foods and beverages. *Advances in Food and Beverage Labelling Information and Regulations*. 2015. p. 191–205.
- [113] Leach Matthew, Hale Elaine, Adam Hirsch, Paul Torcellini. Grocery Store 50% Energy Savings Technical Support Document. September 2009. Technical Report NREL/TP-550-46101.
- [114] British Retail Consortium. A Better Retailing Climate: Driving Resource Efficiency. 2014. See, http://www.brc.org.uk/brc_show_document.asp?id=5443&moid58074.
- [115] Hill F, Courtney R, Levermore G. Towards a Zero Energy Store – A Scoping Study (ZEST). Manchester. Manchester, UK: University of Manchester; 2010. See, <http://www.sci.manchester.ac.uk/uploads/zestfinalreport.pdf>.
- [116] Zisopoulos Filippos K, Rossier-Miranda Francisco J, Jan van der Goot Atze, Boom Remko M. The use of exergetic indicators in the food industry – a review. *Crit Rev Food Sci Nutr* 2017;57(1):197–211.
- [117] Fujii Hidemichi, et al. Decomposition analysis of food waste management with explicit consideration of priority of alternative management options and its application to the Japanese food industry from 2008 to 2015. *J Clean Prod* 2018; 188:568–74.
- [118] Food, Drink Federation. Food and Drink Industry Report 2020. London. 2020.
- [119] Djomo Sylvestre Njakou, et al. Green proteins: an energy-efficient solution for increased self-sufficiency in protein in Europe. *Biofuels, Bioprod. Bioref.* 2020;14: 605–19.
- [120] Roibás L, et al. The relevance of supply chain characteristics in GHG emissions: the carbon footprint of Maltese juices. *Food Res Int* 2018;107:747–54.
- [121] Claudia H. Deutsch, "trying to connect the dinner plate to climate change. *N Y Times* August 29, 2007.
- [122] van Bommel Koen, André Spicer, Wright James D. Slow food as a social movement. *International Encyclopedia of the Social & Behavioral Sciences*. second ed. Elsevier; 2015. p. 94–9.
- [123] Petrini Carlo, Padovani Gigi. *Slow Food Revolution – A New Culture for Eating and Living*. New York: Rizzoli Publications; 2006.
- [124] Barilla Center for Food and Nutrition. Double pyramid. Available at, https://www.barillaefn.com/en/dissemination/double_pyramid/; 2020.
- [125] FAO. The state of food and agriculture – Moving forward on food loss and waste Reduction. Rome. 2019.
- [126] Mourad Marie. Thinking outside the bin: is there a better way to fight 'food waste'? *Berk J Sociol* 2015;59:26–34. 2015.
- [127] Falcone PM, Imbert E. Bringing a sharing economy approach into the food sector: the potential of food sharing for reducing food waste. In: Morone P, Papendiek F, Tartiu V, editors. *Food waste reduction and valorisation*. Springer; 2017.
- [128] Schanes Karin, et al. Food waste fighters: what motivates people to engage in food sharing? *J Clean Prod* 20 February 2019;211:1491–501.
- [129] Ciaghi A, Villafiorita A. Beyond food sharing: Supporting food waste reduction with ICTs. In: 2016 IEEE international smart cities conference (ISC2), trento; 2016. p. 1–6. <https://doi.org/10.1109/ISC2.2016.7580874>.
- [130] Food RethinkX. Agriculture. Available at, <https://www.rethinkx.com/food-and-agriculture/>; 2020.
- [131] Raheem Dele. The need for agro-allied industries to promote food security by value addition to indigenous African food crops. *Outlook Agric* 2011;40(No 4): 343–9.

- [132] Bintsis Thomas, et al. Existing and potential applications of ultraviolet light in the food industry – a critical review. *J Sci Food Agric* 2000;80:637–45.
- [133] Zhang Zhi-Hong, et al. Non-thermal technologies and its current and future application in the food industry: a review. *Int J Food Sci Technol* 2019;54:1–13.
- [134] Rozzi NL, Singh RK. Supercritical fluids and the food industry. *Compr Rev Food Sci Food Saf* 2002;1:33–44.
- [135] Asaithambi Niveditha, et al. Hydrodynamic cavitation and its application in food and beverage industry: a review. *J Food Process Eng* 2019;42:e13144.
- [136] Subhadra Bobban, Grinson-George. Algal biorefinery-based industry: an approach to address fuel and food insecurity for a carbon-smart world. *J Sci Food Agric* 2011;91:2–13.
- [137] Sovacool BK. Replacing tedium with transformation: why the U.S. Department of energy needs to change the way it conducts long-term R&D. *Energy Pol March*, 2008;36(3):923–8.
- [138] Gilberto Vinicius De Melo Pereira, De Carvalho Neto Dão P, De O Junqueira Ana C, Karp Susan G, Letti Luiz AJ, Magalhães Júnior Antonio I, Soccol Carlos R. A review of selection criteria for starter culture development in the food fermentation industry. *Food Rev Int* 2020;36(2):135–67. <https://doi.org/10.1080/87559129.2019.1630636>.
- [139] Dai Qiong, Cheng Jun-Hu, Sun Da-Wen, Zeng Xin-An. Advances in feature selection methods for hyperspectral image processing in food industry applications: a review. *Crit Rev Food Sci Nutr* 2015;55(10):1368–82. <https://doi.org/10.1080/10408398.2013.871692>.
- [140] Kralova Iva, Johan Sjöblom. Surfactants used in food industry: a review. *J Dispersion Sci Technol* 2009;30(9):1363–83. <https://doi.org/10.1080/01932690902735561>.
- [141] El Defrawy, Shaalan HF. Techno-economic assessment of biological treatment and water reuse of effluent from the food industries. *Int J Environ Stud* 2003;60(2): 111–22.
- [142] Alamilla-Beltrán L, Welti-Chanes J, Chanona-Perez JJ, Perea-flores MDJ, Gutierrez-Lopez GF. Emerging technologies for food processing. In: Brennan James G, Grandison Alistair S, editors. *Food processing Handbook*. German: Wiley-VCH Verlag GmbH, KgaA; 2011. p. 205–24.
- [143] Claude Cheftel J. In: Hefnawy M, editor. Emerging risks related to food technology. *Advances in food protection, NATO science for peace and security series A: chemistry and biology*, vol. 1; 2011. https://doi.org/10.1007/978-94-007-1100-6_13.
- [144] Lucilene Dornelles Mello, Kubota Lauro Tatsuo. Review of the use of biosensors as analytical tools in the food and drink industries. *Food Chem* 2002;77:237–56.
- [145] Qiu Liqing, et al. Innovative technologies for producing and preserving intermediate moisture foods: a review. *Food Res Int* 2019;116:90–102.
- [146] Picart-Palmade L, Cunault C, Chevalier-Lucia D, Belleville M-P, Marchesseau S. Potentialities and limits of some non-thermal technologies to improve sustainability of food processing. *Front. Nutr.* 2019;5:130. <https://doi.org/10.3389/fnut.2018.0013>.
- [147] Pan Zhongli, et al. Infrared heating. *Emerging Technologies for Food Processing*. 2014. p. 461–74. <https://doi.org/10.1016/B978-0-12-411479-1.00025-5>.
- [148] Barber Steven T, et al. Closing nutrient cycles with biochar- from filtration to fertilizer. *J Clean Prod* 2018;197:1597–606.
- [149] Kavi Bhushan Singh Chouhan. Critical analysis of microwave hydrodiffusion and gravity as a green tool for extraction of essential oils: time to replace traditional distillation. *Trends Food Sci Technol* October 2019;92:12–21.
- [150] Salehi Fakhreddin. Current and future applications for nanofiltration technology in the food processing. *Food Bioprod Process* 2014;92:161–77.
- [151] Mumith J-A, Makatsoris C, Karayiannis TG. Design of a thermoacoustic heat engine for low temperature waste heat recovery in food manufacturing: a thermoacoustic device for heat recovery. *Appl Therm Eng* 2014;65:588–96.
- [152] Kirby ME. The role of thermo-catalytic reforming for energy recovery from food and drink supply chain wastes. *Energy Procedia* September 2017;123:15–21.
- [153] Kausar Ayesha. A review of high performance polymer nanocomposites for packaging applications in electronics and food industries. *J Plastic Film Sheeting* 2020;36(1):94–112.
- [154] Furszyfer Del Rio DD, Sovacool BK, Bergman N, Makuch KE. Critically reviewing smart home technology applications and business models in Europe. *Energy Pol* September, 2020;144:1–16. 111631.
- [155] Gadanakis Yiorgos, et al. Improving productivity and water use efficiency: a case study of farms in England. *Agric Water Manag* 2015;160:22–32.
- [156] Cimini Alessio, et al. Are the present standard methods effectively useful to mitigate the environmental impact of the 99% EU food and drink enterprises? *Trends Food Sci Technol* 2018;77:42–53.
- [157] Ayodeji Samson Ogunjuyigbe. Retrofitting existing buildings to reduce electrical energy consumption and greenhouse gas emission in Nigerian food and beverage industries. *Journal of Electrical Systems and Inf Technol* 2020;7:9. <https://doi.org/10.1186/s43067-020-00018-3>.
- [158] Cooper Samuel JG, Hammond Geoffrey P, Hewitt Neil, Norman Jonathan B, Tassou Savvas A, Youssef Walid. Energy saving potential of high temperature heat pumps in the UK Food and Drink sector. *Energy Procedia* 2019;161:142–9.
- [159] Law Richard, et al. Opportunities for low-grade heat recovery in the UK food processing industry. *Appl Therm Eng* 2013;53:188–96.
- [160] Maldonado José Miguel, et al. Control strategies for defrost and evaporator fans operation in walk-in freezers. *Int J Refrig* 2018;91:101–10.
- [161] Mukherjee Sanjay, Asthana Abhishek, Howarth Martin, Ryan Mcniell. Waste heat recovery from industrial baking ovens. *Energy Procedia* 2017;123:321–8.
- [162] Tassou SA, et al. Application of tri-generation systems to the food retail industry. *Energy Convers Manag* 2007;48:2988–95.
- [163] Dubois G, Sovacool BK, All C, Nilsson M, Barbier C, Herrmann A, Bruyère S, Andersson C, Skold B, Nadaud F, Dorner F, Moberg KR, Ceron JP, Fischer H, Amelung D, Baltruszewicz M, Fischer J, Benevise F, Louis VR, Sauerborn R. It starts at home? Climate policies targeting household consumption and behavioral decisions are key to low-carbon futures52. ” *Energy Research & Social Science*; 2019. p. 144–58. June.
- [164] Carlsson-Kanyama Annika, et al. Food and life cycle energy inputs: consequences of diet and ways to increase efficiency. *Ecol Econ* 2003;44:293–307.
- [165] Harrington Lloyd. Quantifying energy savings from replacement of old refrigerators. *Energy Procedia* 2017;121:49–56.
- [166] Sovacool BK, Griffiths S, Kim J, Bazilian M. Climate change and industrial F-gases: A critical and systematic review of developments, sociotechnical systems and policy options for reducing synthetic greenhouse gas emissions. *Renew Sustain Energy Rev* May, 2021;141:1–55. 110759.
- [167] Miah JH, et al. A small-scale transdisciplinary process to maximising the energy efficiency of food factories: insights and recommendations from the development of a novel heat integration framework. *Sustain Sci* 2015;10:621–37.
- [168] Jeffrey Rissman et al., Technologies and policies to decarbonize global industry: review and assessment of mitigation drivers through 2070, *Appl Energy* Volume 266, 15 May 2020, 114848.
- [169] Henningsson Stefan, et al. Minimizing material flows and utility use to increase profitability in the food and drink industry. *Trends Food Sci Technol* 2001;12: 75–82.
- [170] Hyde Katherine, et al. The challenge of waste minimisation in the food and drink industry: a demonstration project in East Anglia, UK. *J Clean Prod* 2001;9:57–64.
- [171] Kadiyala Akhil, et al. Development of an assessment tool for pollution prevention and energy efficiency in food industry. *Environ Prog Sustain Energy* 2009;28 (No.3):310–5.
- [172] Guthrie James, Suresh Cuganesan, Ward Leanne. Industry specific social and environmental reporting: the Australian Food and Beverage Industry. *Account Forum* 2008;32(1):1–15. <https://doi.org/10.1016/j.acfor.2007.10.001>.
- [173] Fricko O, et al. Energy sector water use implications of a 2 °C climate policy. *Environ Res Lett* 2016;11:034011.
- [174] Mouratiadou I, et al. Water demand for electricity in deep decarbonisation scenarios: a multi-model assessment. *Climatic Change* 2018;147:91–106.
- [175] Hejazi M, et al. Long-term global water projections using six socioeconomic scenarios in an integrated assessment modeling framework. *Technol Forecast Soc Change* 2014;81:205–26.
- [176] Mouratiadou I, et al. The impact of climate change mitigation on water demand for food and feed: an integrated analysis based on the shared socioeconomic pathways. *Environ Sci Pol* 2016;64:48–58.
- [177] Cole Matthew A, et al. Dirty money: is there a wage premium for working in a pollution intensive industry. *J Risk Uncertain* 2009;39:161–80.
- [178] Burrows David. Carbon price would result in food costs rising 3%. *Food Navigator*, December 2016;1. <https://www.foodnavigator.com/Article/2016/12/01/Carbon-price-would-result-in-food-costs-rising-3>.
- [179] Nelson GC, Rosegrant MW, Koo J, Robertson R. *Climate Change: Impact on Agriculture and Costs of Adaptation*. Washington, D.C.: International Food Policy Research Institute; 2009.
- [180] CDP. The forgotten 10% Climate mitigation in agricultural supply chains September 2015. 2015.
- [181] Smart Climate. Carbon emissions in the food and beverage sector. *A Climate Smart Industry Brief* 2014.
- [182] Ulvenblad Pia, et al. Barriers to business model innovation in the agri-food industry: a systematic literature review. *Outlook Agric* 2018;47(4):308–14.
- [183] Benjamin K. Sovacool, *The Dirty Energy Dilemma*. Praeger; 2008.
- [184] Lim Sarina Abdul Halim, Antony Jiju, Arshed Norin, Albliwi Saja. A systematic review of statistical process control implementation in the food manufacturing industry. *Total Qual Manag Bus Excel* 2017;28(1–2):176–89. <https://doi.org/10.1080/14783363.2015.1050181>.
- [185] Anthony J McMichael John W Powles, Butler Colin D, Uauy Ricardo. Food, livestock production, energy, climate change, and health. *Lancet* 2007;370 (9594):1253–63.
- [186] Interreg. Food sector related knowledge integration: Food sector global market trend analysis report. Central Europe; 2017.
- [187] National Academies of Sciences, Engineering, and Medicine. *Sustainable Diets, Food, and Nutrition: Proceedings of a Workshop*. Washington, DC: The National Academies Press; 2019. <https://doi.org/10.17226/25192>.
- [188] Hall S, Foxon TJ, Bolton R. Investing in low-carbon transitions: energy finance as an adaptive market. *Clim Pol* 2017;17(3):280–98.
- [189] Nolden Colin, Sorrell S, Polzin Friedemann. Catalysing the energy service market: the role of intermediaries. *Energy Pol* 2016;98:420–30.
- [190] Nolden Colin, Steve Sorrell. The UK market for energy service contracts in 2014–2015, vol. 9. *Energy Efficiency*; 2016. p. 1405–20.
- [191] Geddes Anna, Schmid Nicolas, Schmidt Tobias S, Steffen Bjarne. The politics of climate finance: consensus and partisanship in designing green state investment banks in the United Kingdom and Australia *Energy Research & Social Science* November 2020;69. Article 101583.
- [192] Geddes A, Schmidt TS, Steffen B. The multiple roles of state investment banks in low-carbon energy finance: an analysis of Australia, the UK and Germany. *Energy Pol* 2018;115:158–70.
- [193] Steffen B, Schmidt TS. A quantitative analysis of 10 multilateral development banks’ investment in conventional and renewable power-generation technologies from 2006 to 2015. *Nature Energy* 2018.
- [194] Committee on Climate Change. *Net Zero – Technical report* Committee on Climate Change May 2019. London.

- [195] Becken Katja, et al. Avoiding Fluorinated Greenhouse Gases: Prospects for Phasing Out. German Federal Environment Agency (Umweltbundesamt); 08/2011.
- [196] Mota-Babiloni Adrián, et al. Recent investigations in HFCs substitution with lower GWP synthetic alternatives: focus on energetic performance and environmental impact. *Int J Refrig* 2017;82:288–301.
- [197] Catalán-Gil Jesús, et al. Energy evaluation of multiple stage commercial refrigeration architectures adapted to F-gas regulation. *Energies* 2018;11:1915. <https://doi.org/10.3390/en11071915>.
- [198] Cappellaro F, Barberio G, Masoni P. Life cycle management of F-Gas-Free refrigeration technology: the case of F-Gases-Free frozen dessert equipment. In: Finkbeiner M, editor. *Towards life cycle sustainability management*. Dordrecht: Springer; 2011. https://doi.org/10.1007/978-94-007-1899-9_5.
- [199] James SJ, Swain MJ, Brown T, Evans JA, Tassou SA, Ge YT, et al. Improving the energy efficiency of food refrigeration operations. In: *Proceedings of the institute of refrigeration* [session 2008-09, 5-1-5-8]; 2009.
- [200] Sovacool BK, Lovell K, Ting MB. Reconfiguration, contestation, and decline: conceptualizing mature large technical systems. *Sci Technol Hum Val* November, 2018;43(6):1066–97.
- [201] Natural Capital Coalition. “Natural capital protocol – food and beverage sector guide” (Online) Available at: www.naturalcapitalcoalition.org/protocol; 2016.
- [202] Ju Munsol, et al. Food loss rate in food supply chain using material flow analysis. *Waste Manag* 2017;61:443–54.
- [203] International Energy Agency. Paris: France; 2020. See, <https://www.iea.org/reports/sustainable-recovery>. <https://www.iea.org/reports/global-energy-review-2020>.
- [204] Mingzhe Pu, Zhong Yu. Rising concerns over agricultural production as COVID-19 spreads: lessons from China. *Global Food Security* 2020;26:100409.
- [205] Bakalis S, Valdramidis VP, Argyropoulos D, et al. Perspectives from CO+RE: how COVID-19 changed our food systems and food security paradigms. *Current Research in Food Science* 2020;3:166–72. <https://doi.org/10.1016/j.crf.2020.05.003>.
- [206] Rizou Myrto, Galanakis Ioannis M, Turki M, Aldawoud S, Galanakis Charis M. Safety of foods, food supply chain and environment within the COVID-19 pandemic. *Trends Food Sci Technol* 2020;102:293–9. <https://doi.org/10.1016/j.tifs.2020.06.008>. ISSN 0924-2244.
- [207] Benson Thor. Coronavirus vs. Climate Change. *IEEE Spectrum*; 2020. <https://spectrum.ieee.org/energywise/energy/environment/covid19-pandemic-reduce-greenhouse-gas-emissions>. July 23,.
- [208] Peters Glen, et al. Growth in emission transfers via international trade from 1990 to 2008. *Proc Natl Acad Sci Unit States Am* 2018;108(21). . [Accessed 24 May 2011]. 8903–8908.