



**AALBORG UNIVERSITY**  
DENMARK

**Aalborg Universitet**

**CLIMA 2016 - proceedings of the 12th REHVA World Congress**

*volume 2*

Heiselberg, Per Kvols

*Publication date:*  
2016

*Document Version*  
Publisher's PDF, also known as Version of record

[Link to publication from Aalborg University](#)

*Citation for published version (APA):*  
Heiselberg, P. K. (Ed.) (2016). *CLIMA 2016 - proceedings of the 12th REHVA World Congress: volume 2*. Department of Civil Engineering, Aalborg University.

**General rights**

Copyright and moral rights for the publications made accessible in the public portal are retained by the authors and/or other copyright owners and it is a condition of accessing publications that users recognise and abide by the legal requirements associated with these rights.

- ? Users may download and print one copy of any publication from the public portal for the purpose of private study or research.
- ? You may not further distribute the material or use it for any profit-making activity or commercial gain
- ? You may freely distribute the URL identifying the publication in the public portal ?

**Take down policy**

If you believe that this document breaches copyright please contact us at [vbn@aub.aau.dk](mailto:vbn@aub.aau.dk) providing details, and we will remove access to the work immediately and investigate your claim.

# Performance evaluation of two cross type indirect evaporative air coolers

Hui-jeong Kim<sup>1</sup>, Sang-woo Ham<sup>2</sup>, Dong-seob Yoon<sup>3</sup>, Jae-weon Jeong<sup>\*4</sup>

<sup>1,2,3</sup>*Division of Architectural engineering, College of Engineering, Hanyang University, Seoul, 133-791, Republic of Korea*

<sup>1</sup>hj199234@gmail.com

<sup>2</sup>ecosang@gmail.com

<sup>3</sup>dbsehd89@hanyang.ac.kr

<sup>\*4</sup>*Division of Architectural engineering, College of Engineering, Hanyang University, Seoul, 133-791, Republic of Korea*

<sup>\*4</sup>jjwarc@hanyang.ac.kr

## Abstract

*The main purpose of this paper is to conduct comparative analysis of the two types of indirect evaporative coolers (IEC): a typical IEC and a regenerative IEC. The performance of two indirect evaporative coolers were investigated through experimentation under the constant inlet air condition with variable air flow rates. The hot and dry outdoor air condition is selected as an inlet primary air condition which represents the dehumidified air passed through liquid desiccant unit in summer. To compare the cooling capacity of typical IEC and regenerative IEC, the supply air flow rate of regenerative IEC is adjusted in two modes: 1) equal supply air flow rate with typical IEC, 2) 30% less than the supply air flow rate of typical IEC. The performances of two types of IEC are evaluated through experiments in environmental chambers and then validated with numerical models. As a result, the typical IEC showed highest wet-bulb efficiency of 52% while that of regenerative IEC was 36% when supplied with more primary air flow due to extracted secondary air.*

**Keywords – Indirect evaporative cooling; M-cycle; regenerative indirect evaporative cooler;**

## Introduction

The indirect evaporative cooler (IEC) is one of the most promising non-vapor compression system that exhibits substantial potential for energy conservation [1]. The IEC is especially effective for the hot and dry climates where the water evaporation rates increase. Unlike the conventional vapor compression system, IEC requires water as a sole working fluid without any other refrigerant. Therefore, the system consumes only one fourth of cooling energy of conventional vapor compression system [2]. In these reasons, IEC is getting more attention as an energy efficient and environmentally friendly cooling system.

The IEC unit is composed of the consecutive layers of wet and dry channels. The primary air flows into the dry channel of IEC, and relatively cold and dry secondary air flows into the wet channel with water. The water sprayed into secondary channels forms the water film on the surface of the wet channels which evaporates as relatively cold and dry secondary air absorbs the heat from the primary air channels. The primary air exchanges sensible heat with the secondary air without the moisture transfer. Therefore, the outlet temperature of primary air can approach the wet-bulb temperature of the inlet secondary air in an ideal operation.

To enhance the cooling performance of IEC, various types of IEC configurations have been developed and analyzed through numerical models and experiments. Kim et al. (2011) built pilot system of dry coil IEC connected with sensible heat exchanger and tested applicability of the system in hot and humid outdoor air conditions [3]. The test results showed that effectiveness between 20% and 60% can be acquired with the pilot system. Ahmad et al. (2013) tested performance of IEC under various environmental conditions [4]. Riangvilaikul et al. (2010) investigated the performance of counter flow Dew-point IEC through an experiment [5]. The 33% of primary air that passed Dew-point IEC was redirected into the secondary channel as evaporative sink. Woods (2013) suggested a desiccant-enhanced evaporative air conditioner (DEVAP) which consists of a liquid desiccant system and a counter flow Dew-point IEC [6]. The experimental data of both liquid desiccant system and IEC are presented in the paper. By supplying hot and dry air exhausted from liquid desiccant system into the primary channel, IEC even lowers the supply air temperature to near the dew point temperature of the primary air. Anisimov et al. (2014) evaluated the performance of novel cross flow heat and mass exchanger utilizing M-cycle with numerical models [7]. The Dew-point IEC is also called as the regenerative IEC in some papers. Lee (2013) experimented with counter flow regenerative IEC that showed wet-bulb effectiveness in the range of 75% and 90% [8]. Bolotin et al. (2015) compared the performance of typical cross flow IEC with that of cross flow regenerative IEC with numerical models [9]. The simulation results showed that regenerative IEC shows higher COP than that of typical IEC by 35% while obtaining lower cooling capacity due to low primary air flow rate.

Even though many researchers have focused on developing the IEC units to improve the cooling performance, there are relatively few comparative analysis conducted on the basic IEC unit and the regenerative. Therefore, the main purpose of this study is to analyze the performance of cross type dew point-IEC and the typical IEC through the experiment. The performances of two systems are evaluated with the outlet primary air temperature, cooling capacity and wet-bulb effectiveness. The reliability of test results are obtained by comparing the experimental data with the established numerical models [10].

## 2. Theoretical analysis of indirect evaporative coolers

The IEC uses two main air streams: primary air and secondary air. As illustrated in Fig. 1(c), the primary air passes through dry channels of IEC while the secondary air passes through wet channels where water is sprayed to form the water film on the surface of the channel. Along the dry channel, primary air loses sensible heat to relatively cold secondary air, and the heat transferred to adjacent channel evaporates the water on the surface of the wet channel. As dry channels are separated from wet channel by polyethylene film, only sensible heat can be exchanged in this process. The psychrometric process of two main streams and the configuration of typical IEC are illustrated in Fig. 1(a) and Fig. 1(b).

Unlike the typical IEC, the regenerative IEC takes a portion of cooled primary air as a secondary air source as illustrated in Fig. 2(b). As presented in Fig.2 (a) and (c), the secondary air which is primarily cooled from IEC contributes to lowering the outlet temperature of primary air below the wet-bulb temperature of inlet primary air. It is possible to cool the primary air to its dew point temperature that regenerative IEC is also called as dew point IEC. Many researches are focusing on lowering the supply air temperature by using regenerative IEC to increase the cooling capacity of the system.

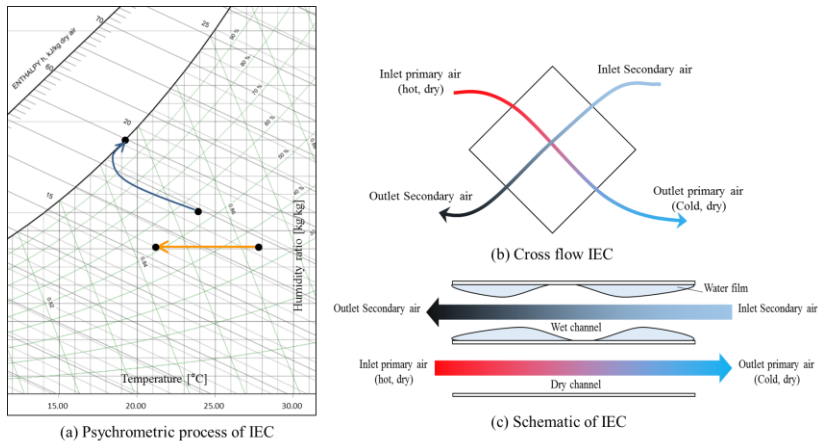

Fig. 1 Cooling process of indirect evaporative cooler

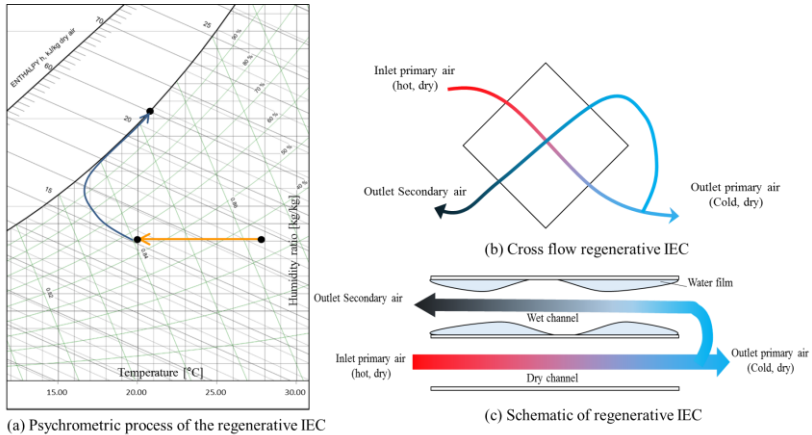

Fig. 2 Cooling process of regenerative indirect evaporative cooler

### 3. Experimental methods

#### 3.1 System construction

The IEC consists of 38 pairs of a unit module which is comprised of a dry channel and a wet channel. The dry channel is made of polyethylene sheet that prevents moisture penetration while the wet channel was composed of paper membrane which evenly absorbs the water. Each channels were filled with corrugated fins with the length and height of 380 mm and 5 mm. The dimensions of IEC unit is specified in Table 1.

The IEC was designed to take two operation modes: typical IEC mode and regenerative IEC mode. As illustrated in Fig 3, the operation mode can be determined by controlling the damper located between the inlet secondary air side and the outlet primary air side. When the IEC operates in typical IEC mode, the damper closes and the two main streams of ambient air flow separately as shown in Fig. 3(a). On the other hand, when IEC works in regeneration mode the damper opens and a part of outlet primary air flows into secondary air side like Fig. 3(b).

Table 1. Specified IEC dimension

Dimension	Value	Units
Dry channel thickness	5	mm
Wet channel thickness	5	mm
Channel length	380	mm
Channel width	380	mm
Plate thickness	0.2	mm
Wet channel thickness	0.2	mm

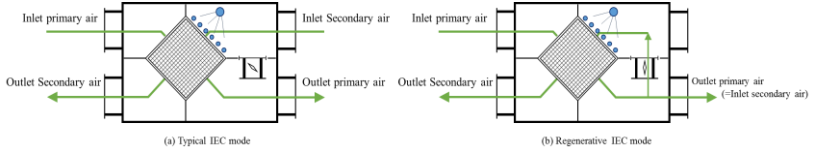

Fig. 3 Two operation modes of IEC

### 3.2 Test equipment and test method

To compare the system performance of the typical IEC and the regenerative IEC under hot and dry outdoor air condition, the system was placed in environmental chamber that maintains the constant temperature and humidity conditions as shown in Fig. 4. Chamber 1 supplied the hot and dry air that simulates the dehumidified air passed through the desiccant system in cooling season. Chamber 2 was activated only in the typical IEC mode to supply the air with the neutral temperature that simulates the indoor air condition as a secondary air stream. Temperature and wet-bulb temperatures were measured by 8 RTD sensors. Four of them were used for measuring the temperature of inlet and outlet conditions of primary and secondary air while others were used for measuring each wet-bulb temperature. Sampling devices were used for measuring the dry-bulb temperature wet-bulb temperature of inlet primary air and secondary air. The temperatures of outlet primary air and secondary air were measured by temperature sensors in code testers. The humidity of each sites were also measured by converting the wet-bulb temperature into humidity ratio. The mass flow rates of each main streams were calculated through the pressure drop measured at the nozzles in the code tester. The accuracy of sensors are described in Table 2.

The biggest difference between typical IEC and regenerative IEC is the ratio of primary to secondary air mass flow rate. The typical IEC operates under balanced flow while regenerative IEC works under unbalanced flow by supplying a portion of primary air into the secondary air channels. To evaluate the performance of two system modes under equivalent condition, it should be considered whether to implement the test under the same primary air condition or to test under equal supply air condition (Case2 and Case 3). Both cases are tested through experiment and compared with the test results of typical IEC (Case 1). The test cases are specified in Table 3.

The performance of IEC is evaluated with wet-bulb effectiveness, cooling capacity, and outlet primary air temperature with (1) and (2).  $T_{p,in}$  and  $T_{p,out}$  represent the inlet and outlet temperature of the primary air, while  $WB_{s,in}$  is the wet-bulb temperature of inlet secondary air.  $\dot{m}$  and  $c_p$  each represent the supply air mass flow rate and the heat capacity of primary air.

$$\text{Wet-bulb effectiveness} = (T_{p,in} - T_{p,out}) / (T_{p,in} - WB_{s,in}). \quad (1)$$

$$\text{Cooling capacity} = \dot{m}c_p (T_{p,in} - T_{p,out}). \quad (2)$$

Table 2. Sensor accuracy

Variable	Sensor type	Range	Accuracy
Dry-bulb Temperature	RTD sensor	-50-150 °C	$\pm(0.15+0.002t)$ °C
Air flow	Differential pressure sensor	0-1250 Pa	$\pm 0.3\%$
Static pressure	Differential pressure sensor	0-1000 Pa	$\pm 0.3\%$
Absolute pressure	Absolute pressure sensor	16-32 inHg	$\pm 0.08\%$

Table 3. Test case description

Air volume [CMH]	Case 1		Case 2		Case 3	
	IEC		Regenerative IEC		Regenerative IEC	
	High	low	High	low	High	low
Primary channel	500	300	500	300	714	428
Secondary channel	500	300	150	90	214	128
Supply air	500	300	350	210	250	300

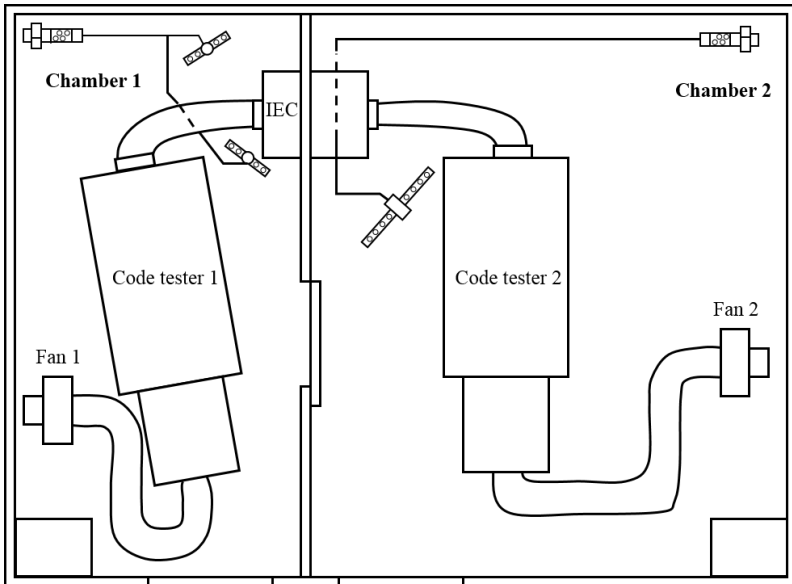

Fig. 4 Schematic of environmental chamber

## 4. Results and discussion

### 4.1 The extraction ratio in regenerative indirect evaporative cooler

To operate regenerative IEC for comparative analysis, the extraction ratio of primary air that results in maximum cooling capacity had to be set. In previous researches, about 30% of extraction ratio was applied in regenerative IEC regardless of the system geometry [3, 4, 6, 9]. Therefore, the experiment was conducted to investigate the optimum extraction ratio of the system by varying the primary to secondary air flow rate ratio from 20% to 70%. The 500 CMH ( $\text{m}^3/\text{hour}$ ) of primary air was constantly supplied with the condition of  $27.5\text{ }^\circ\text{C}$ , 36% RH. As illustrated in Fig. 5, the test result showed that 30% of extraction ratio was responsible for the maximum cooling capacity in the regenerative IEC.

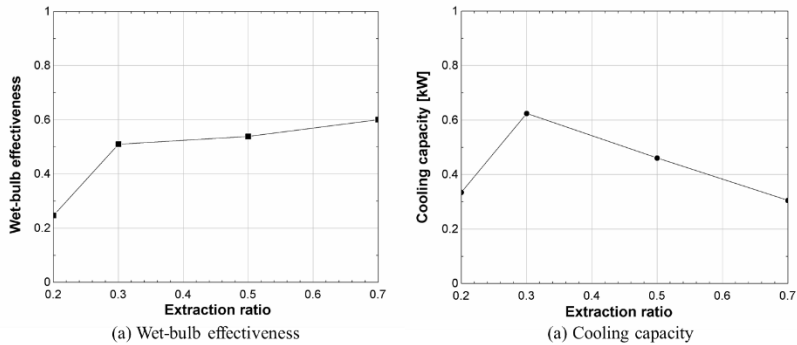

Fig. 5 Effects of extraction ratio in regenerative IEC

### 4.2 Comparative analysis result

The experiment is conducted under three IEC operation modes. As shown in Fig. 6, the measured outlet primary air temperature predicted by the numerical model matches that of the experiments within 5%. The agreement between the test and the model provides the reliability in the test results. The test results presented in Fig. 6 shows that the numerical model underestimated the outlet primary air temperature in some cases. The relatively large amount of water sprayed in the secondary air channel can be responsible for the discrepancies between the outlet primary air temperature of the numerical model and the experiment.

The test conditions of primary and secondary air are marked on the psychrometric chart in Fig. 7. The inlet primary air condition is set to  $27.5\text{ }^\circ\text{C}$ , 36% RH to simulate the ambient air condition that passed desiccant

system during the cooling season. The secondary air of typical IEC is set to 24.3°C, 50% RH to represent indoor air condition. As shown in Fig. 7 (a), the temperature difference between inlet and outlet primary air of typical IEC (i.e., Case 1) is higher than that of regenerative IEC (i.e., Case 2, Case 3) by 2 °C and 0.3°C in high air flow rate. This clearly shows that the high amount of supplied secondary air is more responsible for the temperature decrease in the primary channel than the low secondary air temperature. The test results of Case 2 and Case 3 show that the supply air temperature increases as the total mass flow rate of the primary air increases in the regenerative IEC. Although the wet-bulb effectiveness of Case 2 (i.e., high air volume: 51%, low air volume: 52%) are higher than that of Case 3 (i.e., high air volume: 36%, low air volume: 43%) by 40% and 21%, the cooling capacity of Case 2 (i.e., high air volume: 0.63 kW, low air volume: 0.36 kW) are close to that of Case 3 (i.e., high air volume: 0.6 kW, low air volume: 0.43 kW) with the difference of 0.8% and 1.6%. The relatively high supply air volume of Case 3 which is 43% more than Case 2 reduced the penalty in outlet primary air temperature, and resulted the similar or relatively high cooling capacity to Case 2. The experiment under low primary air volume also followed this trend as shown in Fig. 7(b).

As a result, the typical IEC is more recommended than regenerative IEC when the channel gap is relatively wide (i.e., 5mm). However, with the narrow channel gap, the supply air temperature of the regenerative IEC can be even decreased to attain lower supply air temperature than that of the typical IEC. In some previous researches, the regenerative type showed great cooling performance with the channel gap less than 3mm. Therefore, the test result can be changed when the experiment is conducted with the narrow primary and secondary channel.

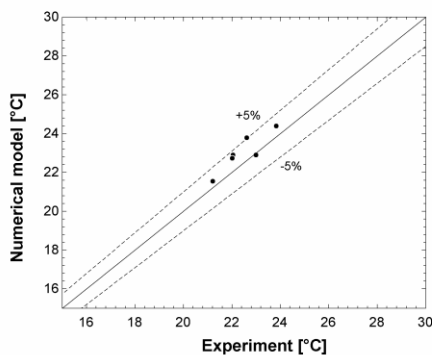

Fig. 6 The primary air outlet temperature of the model and the experiment

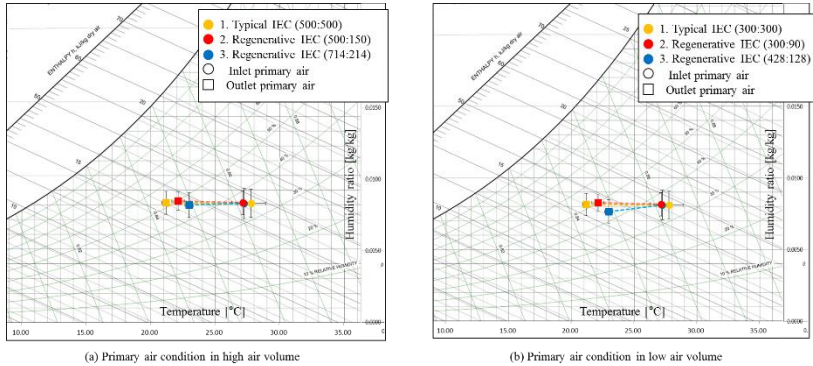

Fig. 7 The temperature changes in primary channel

## 5. Conclusion

In order to evaluate and compare the performances of typical IEC and regenerative IEC, the experiments are conducted under three cases: typical IEC (i.e., Case 1), regenerative IEC with the same amount of primary air with typical IEC (i.e., Case 2), and regenerative IEC with the same amount of secondary air with typical IEC (i.e., Case 3). As a result, the typical IEC showed higher cooling performance than the other two cases with the lower outlet primary air temperature. This clearly shows that the typical IEC is recommended with the channel gap of 5mm. However, the channel size is the one of the most influential factor that affects the performance of IEC. It is obvious that the heat transfer rate can decrease in the wide channels as the primary and secondary air bypass the channel surfaces. Therefore, narrow channel gap is responsible for the low supply air temperature in IEC which can be even lowered near the dew point of the primary air in regenerative IEC. Therefore, further investigation that find the optimum dimension of the IEC have to be conducted to properly evaluate and compare the performances of two types of IEC.

## Acknowledgment

This work was supported by a National Research Foundation of Korea (NRF) grant funded by the Korean government (No. 2015R1A2A1A05001726).

## References

- [1] W. Goetzler, R. Zogg, J. Young, C. J. Energy saving potential and RD&D opportunities for Non-vapor-compression HVAC, Energy Efficiency & Renewable energy. 3673 (2014) March
- [2] Y. Cerci. A new ideal evaporative freezing cycle. International journal of Heat and Mass Transfer. 46 (2003) 2967-74

- [3] MH. Kim, JH. Kim, AS. Choi, and JW. Jeong. Experimental study on the heat exchange effectiveness of a dry coil indirect evaporation cooler under various operating conditions. *Energy*. 36 (2011) 6479-89.
- [4] A. Ahmad, S. Rehman, LM. Al-Hadhrani. Performance evaluation of an indirect evaporative cooler under controlled environmental conditions. *Energy and Buildings*. 62 (2013) 278–85.
- [5] B. Riangvilaikul, S. Kumar. An experimental study of a novel dew point evaporative cooling system. *Energy and Buildings*. 42 (2010) 637–44.
- [6] J. Woods, E. Kozubal. A desiccant-enhanced evaporative air conditioner: Numerical model and experiments. *Energy Conversion and Management*. 65 (2013) 208–20.
- [7] S. Anisimov, D. Pandelidis, A. Jedlikowski, V. Polushkin. Performance investigation of a M (Maisotsenko)-cycle cross-flow heat exchanger used for indirect evaporative cooling. *Energy*. 75 (2014) 593–606.
- [8] J. Lee, DY. Lee. Experimental study of a counter flow regenerative evaporative cooler with finned channels. *International Journal of Heat and Mass Transfer*. 65 (2013) 173–9.
- [9] S. Bolotin, B. Vager, V. Vasilijev. Comparative analysis of the cross-flow indirect evaporative air coolers. *International Journal of Heat and Mass Transfer*. 88 (2015) 224–35
- [10] Z. Liu. Analysis of indirect evaporative heat exchangers: Modeling and experimentation. PhD diss. University of California. (2014) 194.