



**AALBORG UNIVERSITY**  
DENMARK

**Aalborg Universitet**

**CLIMA 2016 - proceedings of the 12th REHVA World Congress**

*volume 9*

Heiselberg, Per Kvols

*Publication date:*  
2016

*Document Version*  
Publisher's PDF, also known as Version of record

[Link to publication from Aalborg University](#)

*Citation for published version (APA):*  
Heiselberg, P. K. (Ed.) (2016). *CLIMA 2016 - proceedings of the 12th REHVA World Congress: volume 9*.  
Department of Civil Engineering, Aalborg University.

**General rights**

Copyright and moral rights for the publications made accessible in the public portal are retained by the authors and/or other copyright owners and it is a condition of accessing publications that users recognise and abide by the legal requirements associated with these rights.

- ? Users may download and print one copy of any publication from the public portal for the purpose of private study or research.
- ? You may not further distribute the material or use it for any profit-making activity or commercial gain
- ? You may freely distribute the URL identifying the publication in the public portal ?

**Take down policy**

If you believe that this document breaches copyright please contact us at [vbn@aub.aau.dk](mailto:vbn@aub.aau.dk) providing details, and we will remove access to the work immediately and investigate your claim.

# Energy Saving Potentials of Desiccant-enhanced Evaporative (DEVap) Cooling System with District Heat Source

Hye-Won Dong <sup>#1</sup>, Su-Young Jo <sup>#2</sup>, Jae-Weon Jeong <sup>\*3</sup>

<sup>#</sup>*Division of Architectural Engineering, College of Engineering,  
Hanyang University, Seoul, 133-791, Republic of Korea*

<sup>1</sup>hwdong3@hanyang.ac.kr

<sup>2</sup>iaslk5058@gmail.com

<sup>\*</sup>*Division of Architectural Engineering, College of Engineering,  
Hanyang University, Seoul, 133-791, Republic of Korea*

<sup>3</sup>jjwarc@hanyang.ac.kr

## Abstract

*The purpose of this study is to estimate energy saving potentials of a desiccant-enhanced evaporative (DEVap) cooling system with district heat source based on a combined heat and power (CHP) system. The DEVap cooling system is an alternative to a vapor compression system. A DEVap cooler is comprised of an internally cooled liquid desiccant dehumidifier and a dew point evaporative cooler and is possible to operate the two devices independently. The liquid desiccant unit of the DEVap requires heat source in the process of regenerating diluted liquid desiccant solution. For that reason, the DEVap, a thermally driven cooling system, has an advantage of using heat energy in cooling season. In this study, district heat source based on the CHP system is applied to the DEVap as a heat source. A cooling coil and a terminal reheating coil are installed auxiliarily to meet supply air temperature set point. Supply air flow rate is modulated according to cooling demand as a variable air volume (VAV) system. This study compared to energy consumption of the DEVap cooling system with the VAV system based on an absorption chiller to evaluate energy saving potentials of the DEVap cooling system. The absorption chiller is also thermally driven cooling system unlike electric chiller. An energy simulation is conducted during the cooling season that performance of cooling system is expected to show biggest difference. The result of this study is predicted the DEVap cooling system with district heat source saves energy compared to VAV system with district heat source in the cooling season.*

**Keywords** – *District heating; liquid desiccant; evaporative cooling; absorption chiller*

## 1. Introduction

Vapor compression systems, widely used for 100 years, have been found to cause global warming and ozone depletion. To solve these problems, many alternative technologies have been studied and introduced. One of the non-vapor compression technologies is a liquid desiccant assisted evaporative

system consisting of a liquid desiccant and an evaporative cooler [1]. The liquid desiccant dries process air and the evaporative cooler cools it. This system requires heat energy for regenerating desiccant solution in the regenerator during the cooling season and can lower peak electrical loads. Heat sources for the regeneration are boilers, waste heat, fuel cell heat, solar thermal heat, and district heating.

Kim et al. [2] introduced a liquid desiccant in evaporative-cooling-assisted 100% outdoor air system, called LD-IDECOAS. The main components of the LD-IDECOAS comprise a liquid desiccant, a direct evaporative cooler, and an indirect evaporative cooler. This system saves 51% of operating energy compared to the conventional variable air volume (VAV) system in the cooling season. Kozubal et al. [1,3] proposed a desiccant-enhanced evaporative (DEVap) cooling system combining a liquid desiccant dehumidifier (LD) with a dew point indirect evaporative cooler (DP-IEC). They simulated the DEVap performance and showed that the DEVap reduced cooling source energy by 61% (a national-average) compared to direct expansion system which is a high efficiency vapor compression system.

The primary objective of this paper is to evaluate the energy saving potentials of the DEVap cooling system with the heat source from district heating (district heat source) based on a combined heat and power (CHP). As heat demands decline in the cooling season, so does energy use efficiency of the CHP. It is expected that the carbon emission will be reduced and the energy use efficiency will increase by using the district heat source based on the CHP for a thermally driven cooling system as the DEVap. The energy consumption of the DEVap cooling system is compared to the conventional VAV system using a single effect absorption chiller, the thermally driven cooling system as the DEVap. A simulation is carried out only during the cooling season that represents performance of the cooling systems well.

## **2. DEVap**

### **2.1. DEVap Cooler**

The DEVap is a decoupled system modulating latent and sensible cooling independently. The LD unit dehumidifies the process air removing latent heat in the first stage. The DP-IEC unit performs the sensible cooling in the second stage, as shown in Fig. 1. The LD unit is composed of an absorber and a regenerator. The desiccant solution flows between the absorber and the regenerator. Lithium chloride (LiCl) is used for the desiccant solution in the DEVap [3]. Dehumidification process in the absorber occurs depending on the vapor pressure difference between the process air and the desiccant solution and releases condensation heat in the desiccant solution. Outdoor air, equal to 50 % of outdoor air intake flow rate, comes to secondary channels to restrain process air heated by deriving water

evaporation [4]. The dehumidification performance degradation is caused by the desiccant solution temperature rising and concentration drop. Therefore, heat should be supplied to regenerate the desiccant solution from the heat source to the regenerator.

Next, the DP-IEC unit is composed of primary channels and secondary channels, and cools the process air inducing water in the secondary channels to evaporate. As shown in Fig. 1, some of the process air is redirected to the secondary channels to enhance evaporative cooling and then Kozubal et al. [3] assumed that extraction rate is 30%.

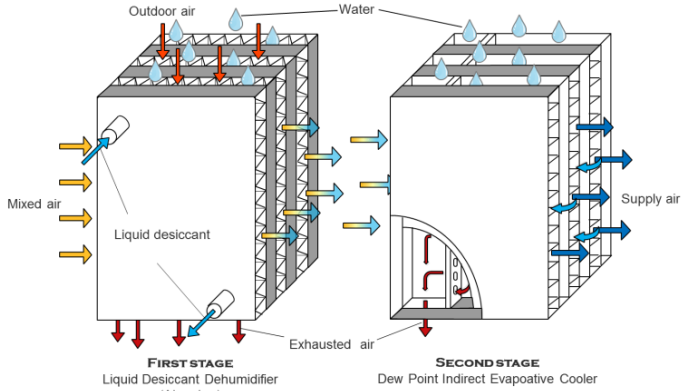

Fig. 1 Schematic diagram of the DEVap cooler

## 2.2. DEVap Cooling System

The DEVap cooler is not sufficient to control supply air set temperature alone. Therefore, a cooling coil and a terminal reheating coil are installed auxiliarily to meet the supply air temperature set point. The supply air flow rate is modulated depending on cooling demands as VAV system. Fig. 2 illustrates proposed DEVap cooling system configuration. The installed cooling coil is driven by the absorption chiller and the reheating coil is a water heating coil.

Outdoor air intake flow rate should be considered first in the DEVap cooling system. Thirty percent of the process air is extracted to the secondary channel of the DP-IEC ( $\dot{m}_{iec,ea}$ ) when the DP-IEC unit of the DEVap operates. More outdoor air should be introduced to satisfy the minimum ventilation rate ( $\dot{m}_{vent}$ ) according to ASHRAE Standard 62.1 [5]. So, the outdoor air intake flow rate is determined by (1). Although the supply air flow rate demand is lower than the minimum ventilation rate, it is set to meet the minimum ventilation rate. The mass balance of air in the cooling season is shown as (2). The outdoor air ( $\dot{m}_{oa}$ ) and the return air ( $\dot{m}_{ra}$ ) for recirculation are mixed for energy saving and the mixed air ( $\dot{m}_{ma}$ ) is used for the supply

air ( $\dot{m}_{sa}$ ) and the exhausted air in the DP-IEC ( $\dot{m}_{iec,ea}$ ). As mentioned earlier, the extraction flow rate in DP-IEC equals 30% of the mixed air.

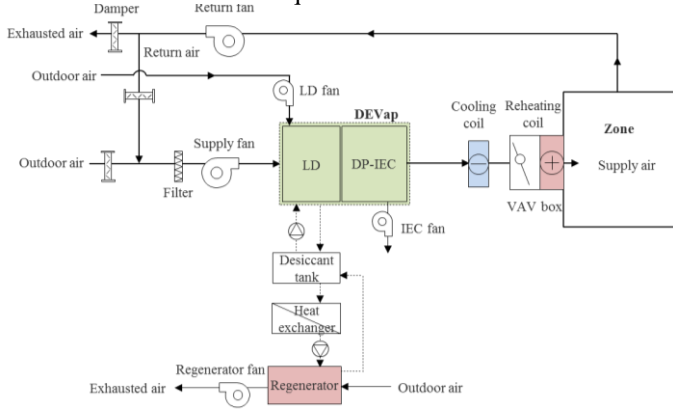

Fig. 2 Proposed DEVap cooling system configuration

$$\dot{m}_{oa} = \dot{m}_{vent} + \dot{m}_{iec,ea} \quad (1)$$

$$\dot{m}_{ma} = \dot{m}_{oa} + \dot{m}_{ra} = \dot{m}_{sa} + \dot{m}_{iec,ea} \quad (2)$$

### 3. District Heat Source

#### 3.1. District Heating

The district heating distributes heat from central plant to residential, commercial, and industrial area by steam or hot water [6]. Using heat from the CHP plant especially can increase efficiency of the CHP Plant. The district heating utilizes surplus heat from CHP plants or resource recovery facilities. The power and thermal efficiency of the CHP is generally 42.1%, 38.6% each in Korea. Absorption chillers are commercialized as the system using the district heat source. The performance of the absorption chiller deteriorates below 80°C due to crystallization [7] and then return water maintains high temperature causing heat recovery rate of the CHP to reduce [6]. For that reason, the researches about liquid desiccant assisted evaporative cooling systems have been rising which do not need to change conventional heat supply facilities or install them. The liquid desiccant assisted evaporative cooling system such as DEVap requires low-temperature heat at the regenerator of the LD, about 40-80°C. So, the temperature differential between supply and return temperature is high to improve energy use efficiency of the CHP plant. In this research, the district heat source from the CHP plant, widely used, is applied to the DEVap cooling system.

#### 3.2. Primary Energy Factor

In general, a primary energy factor of district heating is calculated as (3). It represents the ratio of primary energy input to heat demand. The primary energy factor of the district heating based on the CHP plant, however, is calculated as the ratio of differential between primary energy input and electricity produced from the CHP plant to heat demand, as shown in (4). The electricity is considered as coming from grid and using the primary energy factor of electricity from the grid [8,9].

$$f_{DH} = (\text{primary energy input}) / (\text{heat demand}) \quad (3)$$

$$f_{CHP-DH} = (\text{primary energy input} - \text{electricity production}) / (\text{heat demand}) \quad (4)$$

Table 1 shows each primary energy factor recommended by the Korea Energy Agency [10]. Primary energy factors differ from country to country due to different energy industry characteristics. The primary energy factor of the district heating is lower than that of the fuel because the district heat source generally comes from the CHP plants in Korea. It is appropriate to use the primary energy factor of Korea for recognizing effect of energy type, especially the district heating based on the CHP, considering regional primary energy factors [11-13].

Table 1. Primary energy factor

Energy type	Primary energy factor
Electricity	2.75
Fuel	1.1
District heating	0.728

## 4. Energy Simulation

### 4.1. Simulation Building

Table 2. Simulation building information

Weather	TMY2 weather data		
Occupancy density	5 people/100m <sup>2</sup> [5]		
Volume	300 m <sup>3</sup> (W10 m×D10 m×H3 m, single zone)		
Room set point	Temperature	26 °C	
	Relative humidity	50 %	
Supply air set point	Temperature	15 °C	
Internal heat gain	People	Sensible	75 W/person
		Latent	75 W/person
	Electronics	PC: 140 W/person (Sensible)	
<i>U</i> -values (Window to wall ratio: 17%)	Floor: 0.952 W/m <sup>2</sup> K, Roof: 0.630 W/m <sup>2</sup> K, Exterior wall: 0.468 W/m <sup>2</sup> K, Window: 5.68 W/m <sup>2</sup> K		

A target building for simulation is an office building and is located in Seoul, Republic of Korea. Building loads are simulated using TRNSYS 17, a building energy simulation tool. Occupancy and heating, ventilating, and air conditioning (HVAC) schedules are entered into TRNSYS 17 from ASHRAE Standard 90.1 [14]. Details of the building set condition are illustrated in Table 2. From estimated building loads, the operation energy of each system is calculated with each component model using an Engineering Equation Solver (EES) program.

## 4.2. DEVap Cooler Model

### 4.2.1. Liquid desiccant

It is assumed that solution tank concentration remains 38% constantly and dehumidification rate is equal to regeneration rate. Utilizing Kozubal et al.[4] test data, a linear regression model was derived and it predicts humidity ratio of the absorber outlet ( $w_{abs,a,out}$ ). Parameters of the model are inlet solution concentration ( $C_{abs,s,in}$ ), inlet air temperature ( $T_{abs,a,in}$ ), inlet air humidity ratio ( $w_{abs,a,in}$ ), and liquid to gas ratio ( $LG_{abs}$ ) in the absorber as (5). When design liquid to gas ratio of the absorber is 0.0982, that of the regenerator is 0.38 according to Boranian [15] study. The actual liquid to gas ratio of the regenerator is also assumed to change depending on that of the absorber. The heating load in the regenerator ( $Q_{reg}$ ) is determined by (6). It represents thermal demand for regenerating the desiccant solution. A heat exchanger used in this study is counter flow type and the desiccant solution flowing to the regenerator exchanges heat with the hot water from the heat source. The efficiency of it ( $\epsilon_{hx}$ ) is derived from  $\epsilon$ -NTU method [16].  $C_{min,hw,sol}$  indicates the smaller heat capacity among the hot water and the desiccant solution,  $T_{hws}$  is the hot water temperature, and  $T_{tank,s,out}$  represents the temperature of the desiccant solution coming from the solution tank to the heat exchanger.

$$w_{abs,a,out}=f(C_{abs,s,in}, T_{abs,a,in}, w_{abs,a,in}, LG_{abs}) \quad (5)$$

$$Q_{reg}=\epsilon_{hx} \cdot C_{min,hw,sol} \cdot (T_{hws} - T_{tank,s,out}) \quad (6)$$

### 4.2.2. Dew Point Indirect Evaporative Cooler

It is important to obtain the outlet temperature of the DP-IEC. A simplified  $\epsilon$ -NTU model [17,18] is used for the DP-IEC. After defining the efficiency of DP-IEC as shown in (7), heat exchange rate of DP-IEC ( $Q_{IEC}$ ) is calculated as expressed by (8), and then the outlet temperature of DP-IEC ( $T_{IEC,a,out}$ ) is derived finally by (9). More details of the DP-IEC model are given in [17,18].

$$\varepsilon_{IEC} = [1 - \exp\{-NTU(1 - C^*)\}]/[1 - C^* \exp\{-NTU(1 - C^*)\}] \quad (7)$$

$$\dot{Q}_{IEC} = \varepsilon_{IEC} \cdot C_{min} \cdot (T_{abs,a,out} - WB T_{IEC,a,out}) \quad (8)$$

$$T_{IEC,a,out} = T_{abs,a,out} - (\dot{Q}_{IEC}/c_{p,a} \dot{m}_{abs,a,out}) \quad (9)$$

### 4.3. Variable Air Volume System

The VAV system is operated depends on enthalpy based economizer. The supply air flow rate of the VAV is determined by building loads. The outdoor air flow rate meets the minimum ventilation rate by ASHRAE Standard 62.1 [5], even though the supply air flow rate demand is below the minimum ventilation rate. Cooling the process air is driven by the absorption chiller and the reheating coil in the terminal VAV box operates when over cooling occurs. The reheating coil is provided hot water from boiler or district heat source.

### 4.4. Absorption Chiller and Boiler Model

A chiller model used in this study is the single effect absorption chiller model from EnergyPlus [19,20]. It performs part load operation. The minimum part load ratio is 15%.

A boiler energy use is simulated by a boiler model provided from EnergyPlus [19,20]. Because the outlet water temperature is generally constant, high temperature-cubic curve is used. It has only one independent variable: part load ratio. The theoretical boiler efficiency is assumed to be 82 % [15,19]. The design boiler capacity is 4.688 kW and 5.838 kW in the DEVap and VAV, respectively, and the boiler is operated depending on the heating demands of the regenerator or the reheating coil.

### 4.5. Fans and Pumps Model

A fan power curve is expressed by ASHRAE Standard 90.1 [21]. The fans efficiency is assumed to be 50% as shown in the DEVap [3]. All the fans except the regenerator fan are variable air volume fans. The fan pressure drops are given in Table 3.

Table 3. Fan pressure drop

Fan type	DEVap	VAV
Supply fan	268 Pa	250 Pa
Return fan	200 Pa	200 Pa
LD fan	115 Pa	-
IEC fan	98 Pa	-
REG fan	60 Pa	-

A pump power ( $P_{pump}$ ) is represented as (10) consisting of water density ( $\rho$ ), gravitational acceleration ( $g$ ), water flow rate ( $Q$ ), head ( $H$ ) and pump



efficiency ( $\eta$ ). The head and pump efficiency is set to 20m and 60% each using EnergyPlus default value [19].

$$P_{\text{pump}} = \rho \cdot g \cdot Q \cdot H / 1000 \cdot \eta \quad (10)$$

## 5. Simulation Results

Fig. 3 represents the energy consumption characteristics of both systems in the cooling season. Considering the fan and pump energy using electricity, the VAV uses 49.1% and 63.3% less fan energy than the DEVap, respectively. The DEVap use more fans for the LD, the DP-IEC and the regenerator, and when the DP-IEC operating, additional outdoor air flow rate is required to satisfy the minimum ventilation rate. The DEVap also use the solution pumps in the absorber and the regenerator additionally and the desiccant solution flow rate in the regenerator is relatively high. In the case of the heat energy, it is assumed that the temperature of the heat source is 60 °C in the regenerator of the DEVap. The Absorption chiller model is empirical model and does not represent operating range. General operating temperature range is 80-120°C in the generator of the absorption chiller. As a results, the DEVap reduces 94.7% and 91.9% fuel consumption for absorption chiller and reheating each in comparison with the VAV. Because DEVap cooling system auxiliarily use the absorption chiller and the reheating coil. As a result, the DEVap decreases total fuel consumption by 20.3%.

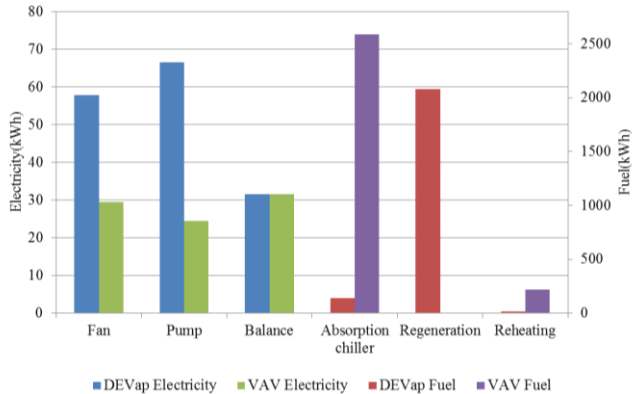

Fig. 3 Energy consumption in summer season

Different types of energy like the electricity and the fuel are converted into the primary energy. The primary energy factor from Korea Energy Agency [10] is applied to convert the electricity and the fuel into the primary energy. First, the DEVap uses 13.0% less primary energy, when supplied

from the grid and the conventional boiler. When district heat source (DHS) is used as the heat source instead of the boiler, the DEVap with the district heat source reduces 48.3% of primary energy compared to the DEVap with the boiler. The DEVap with the district heat source also uses 4.2% less primary energy than the VAV with district heat source, as shown in Fig 4.

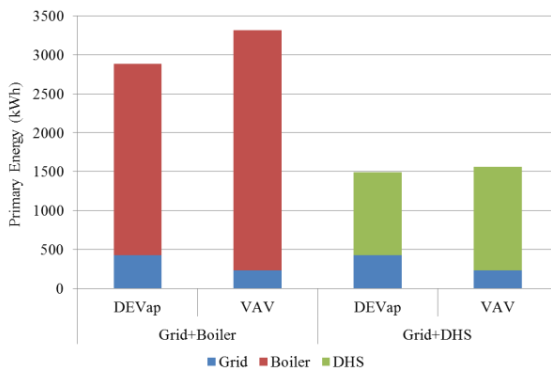

Fig. 4 Primary energy consumption

## 6. Conclusions

In this study, the energy simulation is conducted to evaluate the energy saving potentials of district heat source with the DEVap cooling system, the novel non-vapor compression system, during the cooling season. The DEVap air conditioner with district heat source reduced 48.3% of primary energy compared to the same system with the boiler. The DEVap with district heat source even used 4.2% less primary energy than the VAV when the district heat source used for the heat source. The absorption chiller of this VAV is the commercialized thermally-driven cooling system and the VAV is known for an energy conservation system. Although there is little difference between the energy consumption of the DEVap and the VAV, this result shows energy saving potential in the DEVap. The DEVap has advantages of the decoupled system and sterilizing power of the desiccant solution. Furthermore, the DEVap can improve energy use efficiency of the CHP and also balance the electricity and the heat usage by utilizing district heat source based on the CHP.

In a further study, annual operation of the DEVap with district heat source will be conducted compared to the VAV based on absorption chiller.

## Acknowledgment

This work was supported by a National Research Foundation of Korea (NRF) grant funded by the Korean government (No. 2015R1A2A1A05001726).

## References

- [1] Goetzler W., Zogg R., Young J., and Johnson C., Energy Savings Potential and RD&D Opportunities for Non-Vapor-Compression HVAC Technologies, Navigant Consulting Inc., prepared for US Department of Energy (2014).
- [2] Kim M.H., Park J.S., and Jeong J.W., Energy Saving Potential of Liquid Desiccant in Evaporative-cooling-assisted 100% Outdoor Air System, *Energy*, Volume 59 (2013), 726-736.
- [3] Kozubal E., Woods J., Burch J., Boranian A., and Merrigan T., Desiccant Enhanced Evaporative Air-Conditioning (DEVap): Evaluation of a New Concept in Ultra Efficient Air Conditioning, National Renewable Energy Laboratory (2011).
- [4] Kozubal E., Woods J., and Judkoff R., Development and Analysis of Desiccant Enhanced Evaporative Air Conditioner Prototype, National Renewable Energy Laboratory (2012).
- [5] ASHRAE. ANSI/ASHRAE/IESNA Standard 62.1-2007, Ventilation for Acceptable Indoor Air Quality, Atlanta: American Society of Heating Refrigeration and Air-Conditioning Engineers, Inc., Volume 2007 (2007).
- [6] Phetteplace, G., Bahnfleth, D., Mildenstein, P., Overgaard, J., Rafferty, K., and Wade, D. W., District Heating Guide, ASHRAE, Advertisement formerly in this space (2013).
- [7] Mitchell, J. W., and Braun, J. E., Principles of heating, ventilation, and air conditioning in buildings, Wiley (2013).
- [8] Willem van der Spoel, Ecoheat4Cities as a tool for comparing heating options, The Next DHC Generation Conference, Oct. 10 (2012).
- [9] Ecoheat4cities, Technical report on labelling criteria for DHC, Apr (2011).
- [10] Korea Energy Agency, Building energy efficiency rating certification system operating regulations (2013).
- [11] Building Regulations, The Danish Ministry of Economic and Business Affairs. Copenhagen. December (2010).
- [12] Kurnitski, J., Saari, A., Kalamees, T., Vuolle, M., Niemelä, J., and Tark, T., Cost optimal and nearly zero (nZEB) energy performance calculations for residential buildings with REHVA definition for nZEB national implementation, *Energy and Buildings*, 43 (2011), 3279-3288.
- [13] Smeds, J., and Wall, M., Enhanced energy conservation in houses through high performance design. *Energy and Buildings*, 39 (2007), 273-278.
- [14] ASHRAE. ANSI/ASHRAE/IESNA Standard 90.1-2004, Energy Code for Building Except Low-Rise Residential Buildings, Atlanta: American Society of Heating Refrigeration and Air-Conditioning Engineers, Inc., Volume 2004 (2004).
- [15] Boranian A.P., An Investigation of Optimal Control of Desiccant-Enhanced Evaporative Air Conditioning, M.S thesis, University of Colorado (2012).
- [16] ASHRAE, ASHRAE Handbook-Fundamentals (SI) F04 SI: Heat Transfer (2009).
- [17] Hasan, A., Going below the wet-bulb temperature by indirect evaporative cooling: Analysis using a modified  $\epsilon$ -NTU method, *Applied Energy*, 89 (2012), 237-245.
- [18] Liu Z, Allen W, Modera M., Simplified thermal modeling of indirect evaporative heat exchangers, *HVAC&R Res*, 19 (2013), 257–67.
- [19] EnergyPlus, Input/Output Reference: The Encyclopedic Reference to EnergyPlus Input and Output, Volume 2013 (2013).
- [20] EnergyPlus, Engineering Reference: The Reference to EnergyPlus Calculations, Volume 8.4.0 (2015).
- [21] ASHRAE. ANSI/ASHRAE/IESNA Standard 90.1-2007, Energy Standard for Buildings Except Low-Rise Residential Buildings, Atlanta: American Society of Heating Refrigeration and Air-Conditioning Engineers, Inc., Volume 2007 (2007).