

# An Energy-Efficient Buck-Boost Converter for Mobile Applications

Sunghae Kim<sup>1</sup> and Jaeduk Han<sup>a</sup>

Department of Electronic Engineering, Hanyang University

E-mail: <sup>1</sup>angella1996@hanyang.ac.kr

**Abstract** - In this paper, a single-mode DC-DC Buck-Boost converter using a flying -capacitor is proposed. Since existing DC-DC Buck -Boost Converter has discontinuous output delivery current, DC component of the inductor current is always larger than the load current. This characteristic of the load current increases conduction loss that occurs in the series parasitic resistance (DCR) of the inductor and causes a decrease in the efficiency of the converter. The proposed Buck-Boost Converter secures the characteristics of continuous output delivery current based on Buck operation of LC filtering the switching node voltage. The DC component of the inductor current is always equal to the load current, and total conduction loss can be reduced by designing the number of resistance components in series with the inductor to be one during switching period. The proposed Buck-Boost Converter is manufactured by 180 nm BCDMOS process, and the output voltage can be regulated to 3.3V operating in a single mode with variable input voltages of 2.7 V to 4.2 V. It has a load current range of up to 1 A and uses the PWM Voltage Mode Control method.

**Keywords**—Buck-boost converter, Continuous output delivery current, DCR, Flying-capacitor

## I. INTRODUCTION

In general, a portable electronic device receives a voltage required for an internal integrated circuit from a lithium-ion battery. Lithium-ion batteries have a variable voltage from 2.7 V to 4.2 V depending on the state of charge. A DC-DC converter is required to obtain a regulated supply voltage of 3.3 V from these time-variant battery voltage. For this reason, a Buck-Boost Converter that can regulate both a voltage lower than the input voltage and a voltage higher than the input voltage is used.

The existing switched inductor-type single-mode Buck-Boost Converter has a disadvantage in that the conduction loss is large as two power switches are connected in series to the inductor current path in all switching phases as

resistance components. In addition, due to discontinuous inductor's current transfer characteristics, it always has a larger DC inductor current component than the load current, and the conduction loss generated from the DCR is also large. In terms of Buck-Boost Converter that separates and regulates Buck mode and Boost mode according to the condition of the changing input voltage, when the input voltage has a value close to the output voltage, the efficiency drops sharply, and the controller design becomes complicated.

DC-DC Buck-Boost Converter using a flying-capacitor is proposed to improve the disadvantages of the conventional single-mode Buck-Boost Converter. In all switching phases including flying-capacitor in Power Stage Topology, only one series resistance component exists in the inductor current path, and by securing continuous output current characteristics based on buck operation, the DC component of the inductor current is reduced. In addition, it is designed to enable both Buck operation and Boost operation with a single PWM Voltage Mode Control.

## II. DESIGN CONSIDERATIONS

### A. DC-DC Buck-Boost Converter

DC-DC Buck-Boost Converter is a converter that regulates output voltage that is lower or higher than input voltage. Fig.1 (a) shows the power stage topology of the conventional Buck-Boost converter, and (b) shows the main waveform components according to the switching operation. The inductor is charged in the first phase ( $\phi_1$ ), and it is discharged while transferring energy to the output capacitor in the second phase ( $\phi_2$ ). Since energy is transferred only in the second phase,  $I_{L,DC}$  is always higher than the load current, confirmed by the formula through capacitor-charge balance.

$$I_{L,DC} = \frac{1}{(1-D)} I_{LOAD} \quad (1)$$

The ratio of input voltage and output voltage can be calculated through the Voltage-Second Balance of the inductor, and expressed as an equation including D having a range from 0 to 1 is as follows.

$$D(V_{IN}) + (1 - D)(-V_{OUT}) = 0 \quad (2)$$

a. Corresponding author; jdhan@hanyang.ac.kr

Manuscript Received May 4, 2023, Revised July 9, 2023, Accepted Jul. 20, 2023

This is an Open Access article distributed under the terms of the Creative Commons Attribution Non-Commercial License (<http://creativecommons.org/licenses/by-nc/4.0>) which permits unrestricted non-commercial use, distribution, and reproduction in any medium, provided the original work is properly cited.

$$\frac{V_{OUT}}{V_{IN}}(M) = \frac{D}{(1-D)} \quad (3)$$

$I_{L,DC}$  increases rapidly when  $D$  converges to 1 and the conduction loss from DCR in each phase owing to the resistance component of the power switch increases. Theoretically, voltage conversion ratio should be 0 to infinity, but in reality, it has a finite value. In addition, since the inductor current is always greater than the load current, the conduction loss increases when operating under a large load current condition.

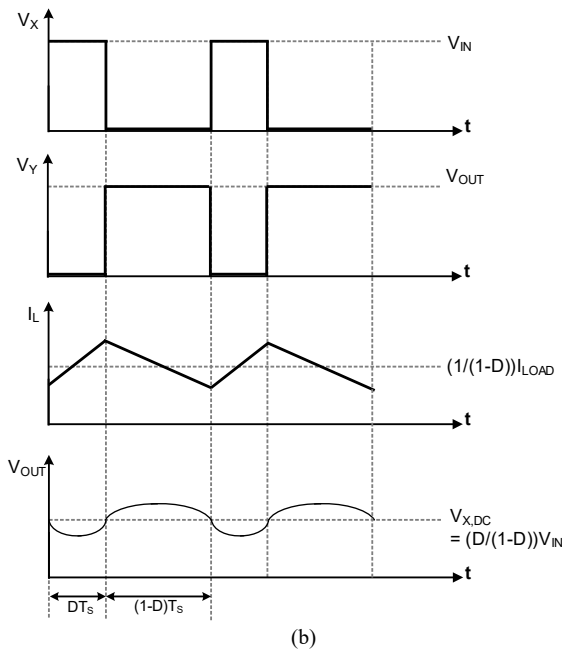
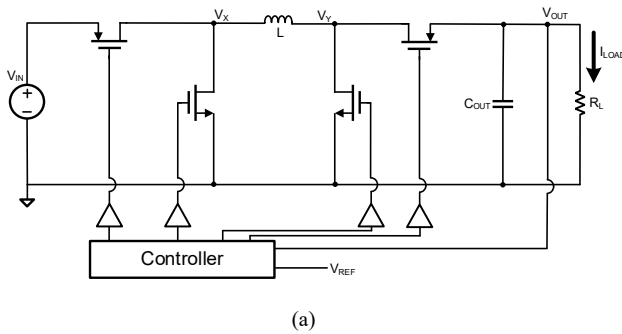

Fig. 1. (a) Power Stage Topology of the existing Buck-Boost Converter and (b) main waveform components according to the switching operation.

### B. Proposed DC-DC Buck-Boost Converter

Fig. 2 is the top schematic of the proposed DC-DC Buck-Boost converter. The structure is shown in Fig. 3, a diagram showing the operation of each of three states and phases of the power stage of the corresponding DC-DC Buck-Boost Converter during one switching period. Respectively The

switching node voltage  $V_X$  has voltages of  $V_{IN}$ , Ground and  $2V_{IN}$ , respectively, and like the Buck Converter, the DC component of  $V_X$  is obtained through the LC filtering of inductor and output capacitor. Flying-capacitor  $C_F$  is charged in the first phase( $\phi_1$ ), and it discharges operating as a voltage source in the third phase ( $\phi_3$ ). Flying-capacitor used in the proposed DC-DC Buck-Boost Converter structure reduces  $\Delta I_L$ , the voltage  $V_L$  across the inductor, and contributes to reducing the conduction loss. In addition, it plays a role of sharing switches used separately in each phase of Buck Mode and Boost Mode.

Duty ratio of each phase was determined in consideration of Capacitor-Charge Balance. Since  $I_{CF, \phi_3}$  current discharging the flying -capacitor in  $\phi_3$  is equal to the inductor current,  $I_{CF, \phi_1}$  which charges flying capacitor in  $\phi_1$  of one switching period  $T_S$  can be obtained as follows.

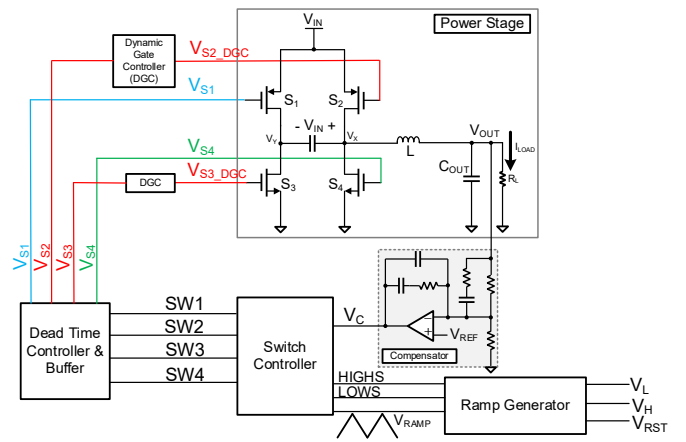

Fig. 2. The overall structure of the proposed DC-DC Buck-Boost Converter.

$$D_1 T_S (I_{CF, \phi_1}) + D_3 T_S (I_{CF, \phi_3}) = 0 \quad (4)$$

$$I_{CF, \phi_3} = -I_L \quad (5)$$

$$I_{CF, \phi_1} = \frac{D_3}{D_1} I_L \quad (6)$$

In Equation (6),  $I_{CF, \phi_1}$  is determined by the ratio of  $D_1$  and  $D_3$ . If  $D_1$  is smaller than  $D_3$ , flying-capacitor needs to be charged for a short time, so the RMS current becomes excessively large, leading to an increase in conduction loss. This happens because  $I_{CF, \phi_1}$  is dependent on the duty ratio, if  $D_1$  and  $D_3$  are set to always equal,  $I_{CF, \phi_1}$  is always equal to the inductor current and is no longer dependent to the duty ratio. Accordingly,  $D_1$  and  $D_3$  are set to the same duty ratio  $D$ , and the duty ratio of  $\phi_2$  is designed to have a value of  $(1-2D)$ . Using the Voltage-Second Balance of the inductor, the ratio of the input voltage to the output voltage is expressed as an equation as follows.

$$D(V_{IN} - V_{OUT}) + (1 - 2D)(-V_{OUT}) + D(2V_{IN} - V_{OUT}) = 0 \quad (7)$$

$$\frac{V_{OUT}}{V_{IN}}(M) = 3D \quad (0 < D < 0.5) \quad (8)$$

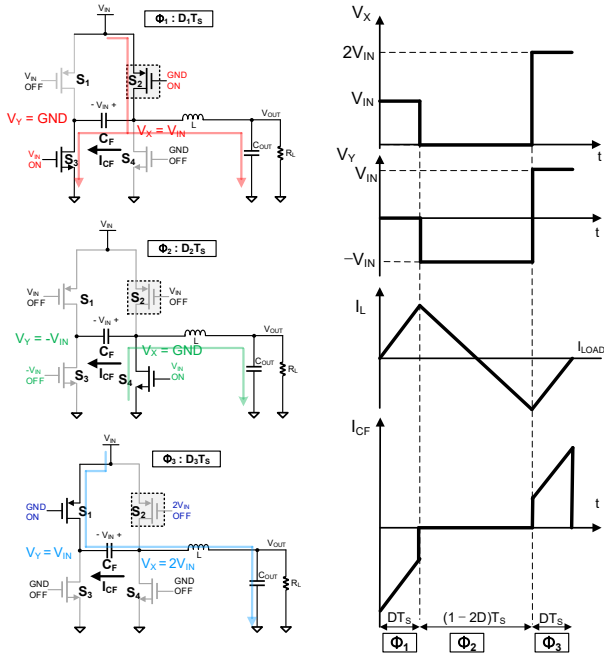

Fig. 3. Switching operation and main waveforms of the proposed DC-DC Buck-Boost Converter.

As a factor causing the conduction loss of a switched inductor-based DC-DC converter, ON resistance of the power switch in turn-on state and the series parasitic resistance (DCR) of the inductor exist. Fig. 4 shows conventional DC-DC Buck-Boost Converter (CBB) and a diagram showing the current flowing through resistance components in each switching phase of Proposed DC-DC Buck-Boost Converter (PRBB). ON resistance of the power switch and the conduction loss generated by DCR are respectively calculated according to the conversion ratio (M), the ratio of the input voltage and the output voltage, as follows.

$$\frac{V_{OUT}}{V_{IN}} (M_{CBB}) = \frac{D_C}{1-D_C} \quad (0 < D_C < 1) \quad (9)$$

$$I_{L,DC,CBB} = \frac{1}{1-D_C} I_{LOAD} \quad (10)$$

$$P_{LOSS,CON,CBB} = 2(1 + M_{CBB})^2 I_{LOAD}^2 R_{ON} + (1 + M_{CBB})^2 I_{LOAD}^2 DCR = (1 + M_{CBB})^2 I_{LOAD}^2 (2R_{ON} + DCR) \quad (11)$$

$$\frac{V_{OUT}}{V_{IN}} (M_{PRBB}) = 3D \quad (0 < D < 0.5) \quad (12)$$

$$I_{L,DC,PRBB} = I_{LOAD} \quad (13)$$

$$P_{LOSS,CON,PRBB} = \left(1 + \frac{4}{3} M_{PRBB}\right) I_{LOAD}^2 R_{ON} + I_{LOAD}^2 DCR = I_{LOAD}^2 \left\{ \left(1 + \frac{4}{3} M_{PRBB}\right) R_{ON} + DCR \right\} \quad (14)$$

Conduction loss was reduced comparing the ratio of the conduction loss that occurred during one switching period under the same load current condition.

Pulse-Width-Modulation (PWM) shown in Fig. 5 is an output voltage control method that modulates the pulse-width by adjusting the duty ratio of a switching pulse with a fixed switching frequency. Since it has a constant switching frequency, only the frequency component corresponding to the switching frequency and the switching harmonics exist, which has the advantage of being easy to control Electric-Magnetic-Interference (EMI). Duty ratio is determined by switch controller whose input voltages are Ramp voltage and  $V_C$ , output voltage of Type III Compensator.

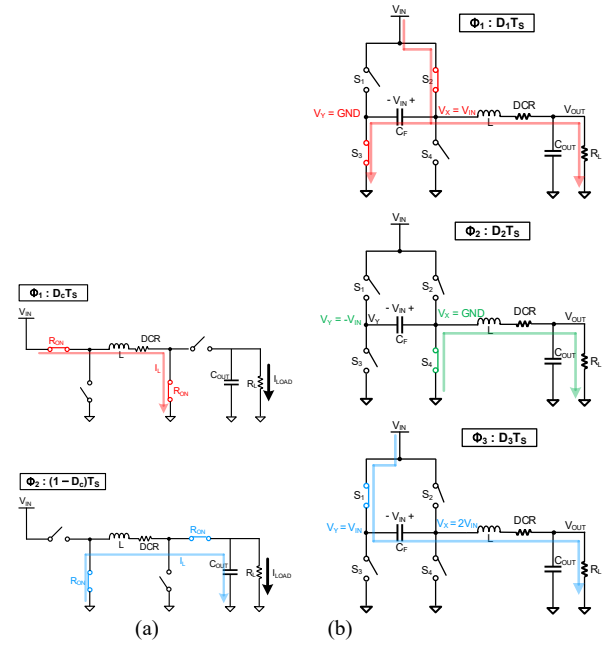

Fig. 4. Resistance component and current flow in each switching phase of (a) the existing DC-DC Buck-Boost Converter (CBC) and (b) the Proposed DC-DC Buck-Boost Converter (PRBB).

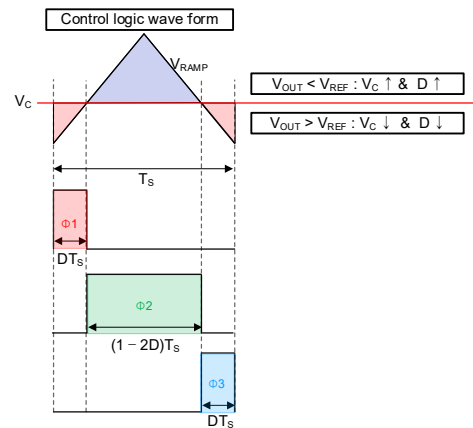

Fig. 5. PWM operation of the proposed DC-DC Buck-Boost Converter.

If output voltage is greater than the reference voltage,  $V_C$  decreases to reduce the Duty Ratio, therefore, DC component of switching node  $V_X$  delivered to the output node during the switching period is decreased and control the output voltage to be decreased. Conversely, if the output voltage is lower than the reference voltage,  $V_C$  increases to make duty ratio larger.

TABLE I. PERFORMANCE COMPARISON TO PRIOR WORKS

	[4] TIEL 2019	[5] TPEL 2020	[6] TPEL 2021	This work
Technology	180nm BCD	180nm BCD	130nm BCD	<b>130nm BCD</b>
Topology	State-based Buck-boost (S3B)	DSM-based NIBB	Digitally assisted buck-boost	<b>Flying-capacitor assisted single mode buck-boost</b>
Input voltage [V]	2.7 – 4.2	2.5 – 5.0	2.3 – 5.0	<b>2.7 – 4.2</b>
Output voltage [V]	3.4	2.0 – 4.6	1.5 – 3.6	<b>3.3</b>
Load current [A]	0.5 – 1.1	0.1 – 0.5	0.001 – 1.0	<b>0.1 – 1.0</b>
Inductor [uH]	4.7	3	0.22	<b>4.7</b>
Number of Mode	3	3	3	<b>1</b>
Mode control method	Current mode state-based control	Voltage mode Delta-sigma modulation	Peak-current-mode PWM & constant-peak-current PFM	<b>Voltage mode PWM</b>
Mode transition	Required	Required	Required	<b>Not required</b>
Switching frequency [Hz]	1M	14M	6M	<b>1M</b>
# of max series resistances in inductor current path	Buck / Buck- Boost / Boost	Buck / Buck- Boost / Boost	Buck / Buck- Boost / Boost	-
	2 / 2 / 2	2 / 2 / 2	2 / 2 / 2	<b>1</b>
Load capacitor [uF]	10	20	10	<b>5</b>
Flying capacitor [uF]	-	-	-	<b>5</b>
Continuous output delivery current	NO	NO	NO	<b>YES</b>
Peak Efficiency	90.9%	94.8%	91.7%	<b>96.7%</b>

III. SIMULATION RESULTS

The characteristics to be verified in the proposed Buck-Boost Converter are that the output voltage is regulated to 3.3 V, and efficiency that appear when the load current is swept from 100 mA to 1A for the input voltage of 2.7 V to 4.2 V.

Fig.6 shows regulated output voltage waveform when input voltages are 2.7 V and 4.2 V. In both different input voltage condition, the proposed Buck-Boost Converter can regulate the output voltage of 3.3V. Moreover, the operation of switching nodes  $V_X$  and  $V_Y$  under the condition of an input voltage of 2.7 V is shown in Fig.7. Having three different voltage levels in switching node  $V_X$  and  $V_Y$ , it can minimize the voltage difference generated in inductor in each phase, which helps reducing DCR conduction loss.

Performance comparison to prior works is shown in Table 1. The proposed Buck-Boost converter has continuous output delivery current characteristics and operates without mode transition using less load capacitor and flying capacitor compared to previous works. It has the highest peak efficiency among other works which is 96.7%.

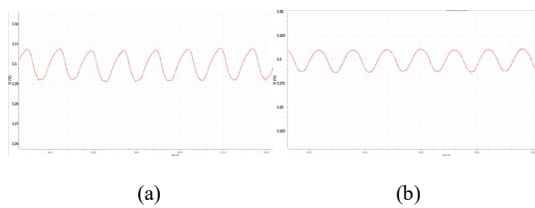

Fig. 6. Output voltage waveform for (a) 2.7 V input voltage and (b) 4.2 V input voltage.

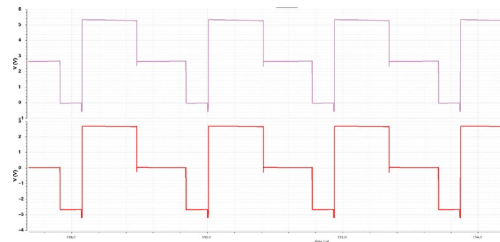

Fig. 7. 2.7 V Switching Node for input voltage  $V_X$  and  $V_Y$  waveform.

IV. CONCLUSIONS

Li-ion changing from 2.7 V to 4.2 V through the proposed Buck-Boost Converter can regulate a constant output voltage of 3.3 V with respect to the input voltage of the battery. Proposed Buck-Boost Converter has a simple power stage structure and there is only one series resistance component in the inductor current path in all switching phases including the flying-capacitor. Conduction loss was improved by reducing the DC component of the inductor current. Thanks to the three-phase operation, the efficiency is prevented from rapidly decreasing when input voltage approaches to the regulated voltage, and overall efficiency of more than 90% can be guaranteed in the range of 100 mA to 1 A load current. The expected peak efficiency of 2.7 V input voltage is 96.7% when the load current is 0.2 A.

ACKNOWLEDGMENT

The chip fabrication was supported by the IC Design Education Center (IDEC, HM-2101)

## REFERENCES

- [1] Y. Huh, S. Hong and G. Cho, "A Hybrid Structure Dual-Path Step-Down Converter With 96.2% Peak Efficiency Using 250-m  $\Omega$  Large-DCR Inductor," in IEEE Journal of Solid-State Circuits, vol. 54, no. 4, pp.959-967, April 2019.
- [2] S. Shin et al., "A 95.2% efficiency dual-path DC-DC step-up converter with continuous output current delivery and low voltage ripple," 2018 IEEE International Solid – State Circuits Conference – (ISSCC), San Francisco, CA, 2018, pp. 430-432.
- [3] S. Wang, Y. Woo, Y. Yuk, G. Cho, "High efficiency Single-Inductor Boost/Buck Inverting Flyback converter with hybrid energy transfer media and multilevel gate driving for AM OLED panel," 2010 Symposium on VLSI Circuits, Honolulu, HI, 2010, pp. 59-60.
- [4] K. -D. Kim, H. -M. Lee, S. -W. Hong and G. -H. Cho, "A Noninverting Buck–Boost Converter with State-Based Current Control for Li-ion Battery Management in Mobile Applications," in IEEE Transactions on Industrial Electronics, vol. 66, no. 12, pp. 9623-9627, Dec. 2019.
- [5] Y. -K. Cho and K. C. Lee, "Noninverting Buck–Boost DC–DC Converter Using a Duobinary-Encoded Single-Bit Delta-Sigma Modulator," in IEEE Transactions on Power Electronics, vol. 35, no. 1, pp. 484-495, Jan. 2020.
- [6] M. Singh and A. A. Fayed, "A 1-A 6-MHz Digitally Assisted Buck–Boost Converter with Seamless Mode Transitions and Fast Dynamic Performance for Mobile Devices," in IEEE Transactions on Power Electronics, vol. 36, no. 4, pp. 4338-4351, April 2021.



**Sunghae Kim** received the M.S. degree in electronic engineering from Hanyang University, Seoul, Korea in 2021.

Her main interests include the power electronic circuit design.



**Jaeduk Han** received the Ph. D. degree in electronic engineering from University of California at Berkeley, CA, USA in 2017 and is currently an assistant professor at Hanyang University, Korea.

His main interests include the power electronic circuit design.